



HEIDENHAIN



Digital Readouts

Linear Encoders

For Manually Operated
Machine Tools

May 2014

Digital readouts from HEIDENHAIN are used in a wide variety of applications. These include machine tools, infeed axes (e.g. on saws and presses), measuring and inspecting equipment, dividing apparatuses, setting tools, and measuring stations for production control. In order to meet the requirements of these applications, many encoders from HEIDENHAIN can be connected to the digital readouts.

The main application for digital readouts with two or more axes is on manually operated machine tools. Whether milling, drilling, boring or turning, the field-proven cycles provide the operator with optimal support. Digital readouts show the current position quickly and clearly, enabling a significant increase in work productivity. The most important linear encoders for position measurement on manually operated machine tools are also listed in this brochure.

You can find other encoders for connection to the digital readouts on the Internet at www.heidenhain.de, or in the *Linear Encoders for Controlled Machine Tools*, *Length Gauges*, *Angle Encoders* and *Rotary Encoders* product catalogs.

In addition to digital readouts, HEIDENHAIN also offers evaluation electronics that find application particularly in SPC inspection stations, tool presetters, profile projectors, measuring microscopes, or coordinate measuring machines. These **evaluation electronics for metrological applications** feature either an integrated display or a connection for a PC.

More information is available on the Internet at www.heidenhain.de or in the *Evaluation Electronics For Metrology Applications* product catalog.

Comprehensive descriptions of all available interfaces as well as general electrical information are included in the *Interfaces for HEIDENHAIN Encoders* brochure.

This catalog supersedes all previous editions, which thereby become invalid. The basis for ordering from HEIDENHAIN is always the catalog edition valid when the contract is made.

Standards (ISO, EN, etc.) apply only where explicitly stated in the catalog.



Contents

Digital readouts			
Overview	HEIDENHAIN digital readouts		4
	Selection guide		6
Functions	Probing functions for datums (ND 780, POSITIP, ND 1200 R)		8
	Tool compensation (series ND 500, ND 780, POSITIP)		9
	Distance-to-go display (all digital readouts)		10
	Hole patterns (series ND 500, ND 780, POSITIP, ND 1200 R)		11
	Contour monitoring (ND 500, POSITIP)		12
	Rectangular pockets (POSITIP)		12
	Help when working with lathes (series ND 500, ND 780, POSITIP)		13
	Programming of machining steps (POSITIP, ND 1200 R)		14
	For fast and standard radial drills (ND 1200 R)		15
Specifications	ND 280 – Digital readout for one axis		16
	ND 500 series – Straightforward display units for two and three axes		18
	ND 780 – Adaptable digital readout for up to three axes		20
	POSITIP 880 – The programmable digital readout for up to six axes		22
	Series ND 1200 R – Digital readouts for conventional and fast radial drilling machines		24
Mounting			26
Electrical connection	Encoders		31
	Interfaces		33
	Accessories		42
	Cable overview		43
Linear encoders for manually operated machine tools			
Overview			46
Specifications	LS 300 series		48
	LS 600 series		50
Mounting instructions			52
Electrical connection	Interfaces	Incremental signals $\sim 1 V_{PP}$	53
		Incremental signals \square TTL	54
	Cables and connecting elements		55

HEIDENHAIN digital readouts

– Designed for the real world

HEIDENHAIN digital readouts have universal application: In addition to standard tasks on milling, drilling and boring machines and lathes, they also offer ideal solutions for many applications on machine tools, measuring and testing equipment, and special machines—in fact all machines where axis slides are traversed manually.



Versatile, ergonomic, and well thought-out

Digital readouts from HEIDENHAIN are designed for user friendliness.

Typical characteristics:

- Highly readable graphic display
- Graphic support and help functions
- Conversational user guidance
- A simple, logically arranged keypad helps you quickly master the available functions and enter positions reliably and rapidly
- Ergonomically designed push-button keypad with symbols that withstand years of use.
- Splash-protected front panel prevents coolant from damaging your digital readout.
- Sturdy cast-metal housing built for the worst of day-to-day workshop conditions.



– Operational advantages

Fast

HEIDENHAIN digital readouts save you time. The distance-to-go display feature allows you to approach the next nominal position quickly and reliably, simply by traversing to a display value of zero. Datums can be set wherever needed. This simplifies positioning, especially for workpieces with complicated dimensions.

When milling or boring hole patterns or rectangular pockets, the geometric data can be entered simply and quickly. You move the axis to target positions with the distance-to-go display.

On lathes, the sum display feature for saddle and top slide contributes to more accurate positioning. If taper dimension data are not complete, the display will help the operator to calculate the angles.

The POSITIP is ideal for small-batch production, because repetitive machining sequences can be stored as programs and then used as often as required.

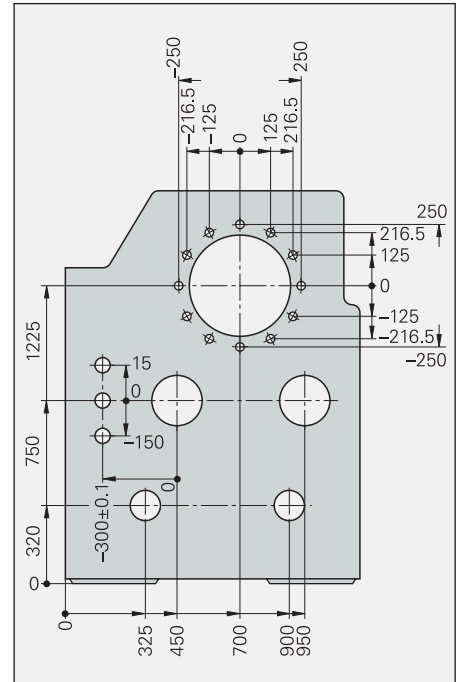

Reliable

A highly readable display shows the measured positions with respect to the selected datum. As a result, the probability of error is reduced and machining becomes more reliable.

The graphic positioning aid of the POSITIP, ND 780 and ND 52x improves the speed and reliability of the distance-to-go display. Graphic illustrations help you to enter the geometric data correctly.

Accurate

On older machine tools, precise machining in the range of 0.01 mm is a matter of luck, since worn machine elements make exact dial and vernier settings impossible.

Linear encoders from HEIDENHAIN sense machine slide movement directly. The backlash caused by mechanical transfer elements such as lead screws, racks and gears therefore has no influence. By determining the slide position directly, you achieve higher machining accuracy and reduce scrap rates.

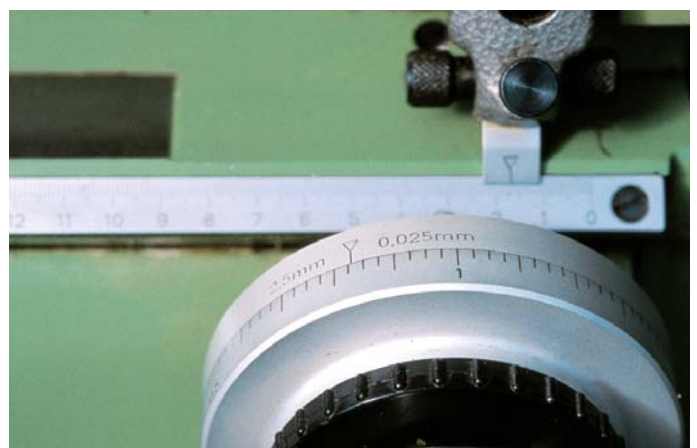

Selection guide

	Number of axes	Reference points/ Tool data	Functions
ND 200 series Digital readouts for measuring devices, adjustment and testing equipment, automated tasks, as well as simple infeed and positioning tasks with one axis <ul style="list-style-type: none"> • Monochrome (ND 280) or color screen (ND 287) • Splash-proof full-travel keyboard • Switching inputs/outputs (ND 287) 	1	2 reference points	– <ul style="list-style-type: none"> • Distance-to-go display • Metrological and statistical functions (sorting and tolerance checking, measurement series, SPC) • Offsetting a second encoder (optional) for sum/difference display, temperature compensation
ND 500 series Digital readout for milling, drilling and boring machines, as well as lathes, with two or three axes <ul style="list-style-type: none"> • Monochrome screen • Membrane keyboard 	2	10 datums; 16 tools	<i>General:</i> <ul style="list-style-type: none"> • Distance-to-go display with graphic positioning aid • Contour monitoring <i>Milling and drilling:</i> <ul style="list-style-type: none"> • Hole patterns (circular and linear patterns) • Tool compensation <i>Turning:</i> <ul style="list-style-type: none"> • Radius/Diameter display • Separate and sum display
	3		
ND 780 Digital read out for milling, drilling and boring machines, as well as lathes, with up to three axes <ul style="list-style-type: none"> • Monochrome screen • Splash-proof full-travel keyboard • Switching inputs/outputs (via IOB 49) 	Up to 3	10 datums; 16 tools	<i>General:</i> <ul style="list-style-type: none"> • Distance-to-go display with graphic positioning aid <i>Milling and drilling:</i> <ul style="list-style-type: none"> • Hole patterns (circular and linear patterns) • Tool compensation • Probing functions for datums <i>Turning:</i> <ul style="list-style-type: none"> • Radius/Diameter display • Separate and sum display • Constant surface speed (via IOB 49)
POSITIP 880 Digital readout for milling, drilling and boring machines with up to six axes , and for lathes <ul style="list-style-type: none"> • Color screen • Program memory • Splash-proof full-travel keyboard • Switching inputs/outputs (via IOB 89) 	Up to 6	<i>Milling and drilling:</i> 99 datums; 99 tools <i>Turning:</i> 1 datum; 99 tools	<i>General:</i> <ul style="list-style-type: none"> • Distance-to-go display with graphic positioning aid • Contour monitoring • Programming of machining steps <i>Milling and drilling:</i> <ul style="list-style-type: none"> • Hole patterns (circular and linear patterns) • Tool compensation • Probing functions for datums • Roughing out rectangular pockets <i>Turning:</i> <ul style="list-style-type: none"> • Radius/Diameter display • Separate and sum display • Turning with allowances • Turning
ND 1200R RADIAL-DRILL series Digital readouts for fast and conventional radial drills <ul style="list-style-type: none"> • Monochrome screen • Full-travel keyboard • Switching inputs 	2	1 datum	<ul style="list-style-type: none"> • Conversion of polar (RA) to Cartesian coordinates (XY) • XY/RA switch-over • Distance-to-go display in machine coordinates R and A • Hole patterns (circular and linear patterns) • Probing functions for workpiece orientation and datums
	3		

Encoder inputs	Switching I/O	Data interface	Type	Page
\sim 1 V _{PP} \sim 11 μ A _{PP} EnDat 2.2	–	RS-232-C/V.24 USB	ND 280	16
	Yes	RS-232-C/V.24 USB Ethernet (option)	ND 287	Catalog: Evaluation Electronics
\square TTL	–	USB	ND 522	18
			ND 523	
\sim 1 V _{PP} \sim 11 μ A _{PP}	<ul style="list-style-type: none"> • For KT edge finder • For edge finder with contact triggering • Additional via IOB 49 	RS-232-C/V.24	ND 780	20
\sim 1 V _{PP} \sim 11 μ A _{PP} EnDat 2.1	<ul style="list-style-type: none"> • For KT edge finder • Additional via IOB 89 	RS-232-C/V.24; Centronics	PT 880	22
\sim 1 V _{PP} \square TTL	<ul style="list-style-type: none"> • Zero reset • Measured value output • For KT edge finder 	RS-232-C/V.24 USB	ND 1202R	24
			ND 1203R	



Functions

– Probing functions for datums (ND 780, POSITIP, ND 1200 R)

Easy setup with probing functions

A very useful accessory for datum setting is the HEIDENHAIN KT edge finder. Simply move the edge finder toward a side of the workpiece until the stylus deflects. The counter automatically stores the exact position, taking into account the direction of approach and the radius of the stylus. In milling machine mode, the ND 780, ND 1200 R und POSITIP digital readouts offer the following probe functions:

- Workpiece edge as reference line
- Workpiece centerline as reference line
- Circle center as datum

For electrically conductive workpieces, these functions are also possible on the ND 780 with an edge finder with contact triggering to ground.

Datum finding with the tool

The probe functions can also be performed with the tool.

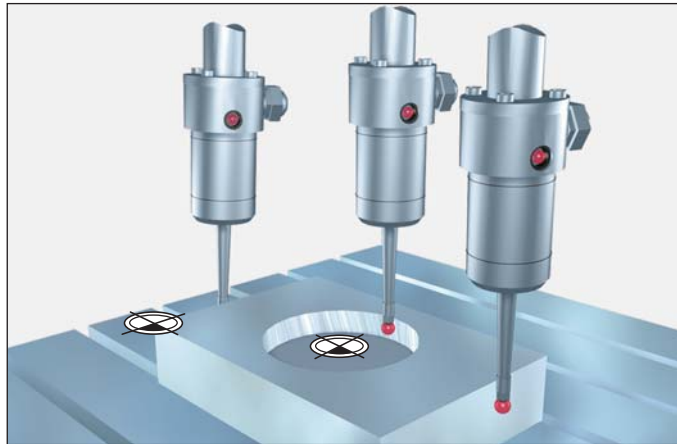

Accessory: KT edge finder

The KT is a triggering edge finder. The cylindrical stylus is spring-mounted in the edge finder housing. The stylus is deflected when it contacts the workpiece, and the edge finder sends a triggering signal over the connecting cable to the ND or the POSITIP.

The KT edge finder allows you to set datums quickly and easily, without leaving marks on the workpiece.

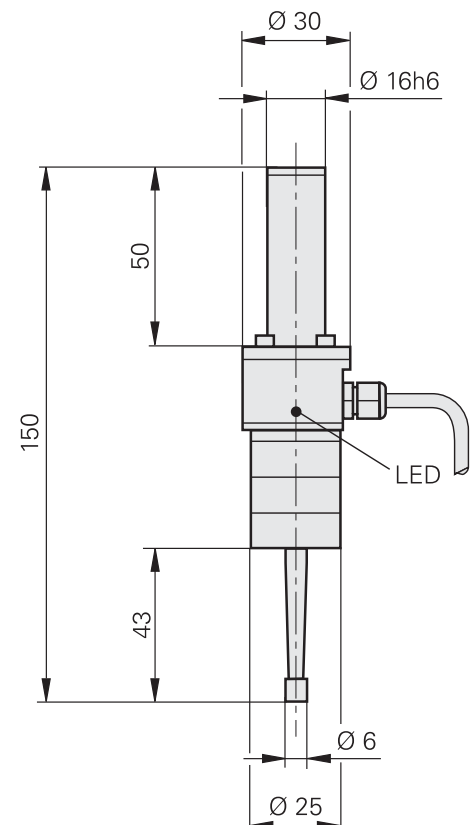

– Tool compensation (series ND 500, ND 780, POSITIP)

Tool compensation for milling machines

The digital readouts of the ND 500, ND 780 and POSITIP series can save tool data, i.e. diameter, and the POSITIP also saves the length and axis of the tool in use. The POSITIP 880 features a tool table for 99 tools, in which the data of pre-set tools or tool data determined on the machine can be stored.

When positioning in distance-to-go mode, the readouts take the tool radius (R+ or R-) in the machining plane into account, and the POSITIP also considers the tool length (ΔL) in the spindle axis.

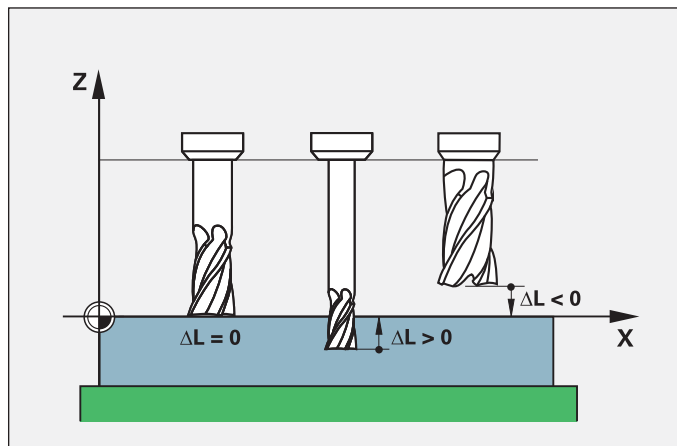
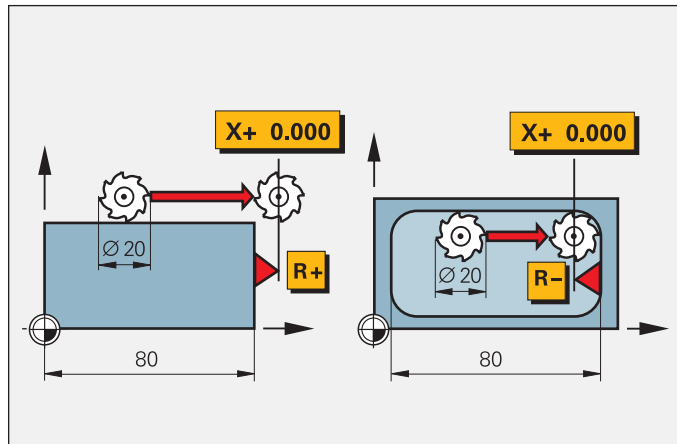

Determining and storing tool compensation values on lathes

With the ND 52x or ND 780 (16 tools) and the POSITIP (99 tools) readouts, you can store the dimensional data for the tools you insert in the turret or quick-change holder:

- Enter the tool position directly when turning the first diameter, or
- “freeze” the current axis position value, retract the tool, measure the turned diameter and then enter that value.

Changing datums

If you change the workpiece or the workpiece datum, you can fix the new datum without having to change the stored tool-offset values. The tool data are automatically referenced to the new datum.

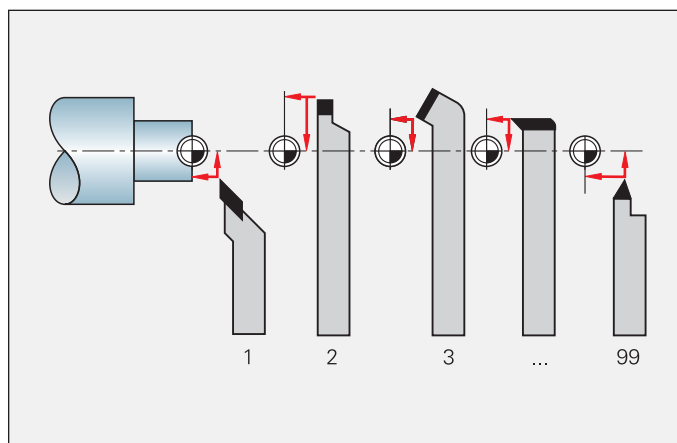

Functions

– Distance-to-go display (all digital readouts)

Distance-to-go display for turning and milling

The distance-to-go display feature simplifies your work considerably: you enter the next nominal position, and the display shows you the distance remaining to the target position. This means, you simply move to the display value zero.

The displays for milling can also compensate the cutter radius. In this way you can directly use the drawing dimensions without having to do any conversions. You no longer have to remember any complicated values.

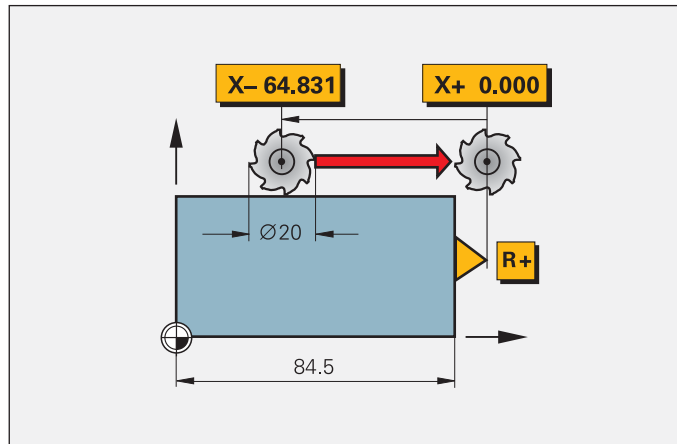

On POSITIP, the distance-to-go display is enhanced by a graphic positioning aid: As you traverse to zero, a square cursor moves into a target fork. If you prefer (for example for turning), the display can show the absolute position value instead of the graphic.

POSITIP's distance-to-go display

With POSITIP you can turn while compensating for **oversizes**. Simply enter the oversize and use the distance-to-go display to traverse to zero.

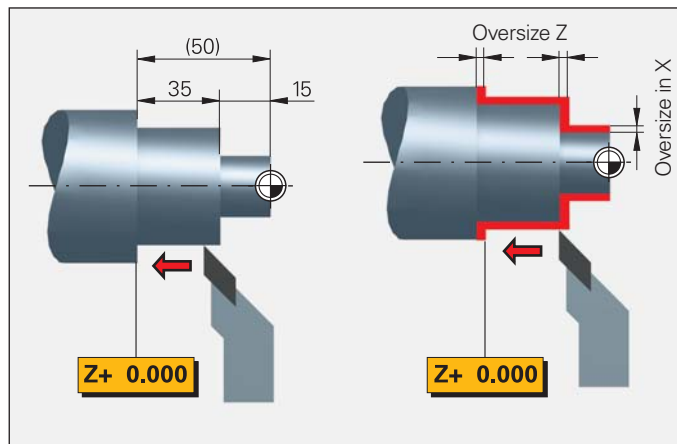

– Hole patterns (series ND 500, ND 780, POSITIP, ND 1200R)

Automatic calculation of bolt hole patterns for milling and drilling

In milling machine mode you can machine **bolt hole circles** (full circle or circle segments) and **linear hole patterns** without having to calculate:

You simply enter the geometric dimensions and the number of holes from the drawing. The display calculates the coordinates of the individual holes in the working plane. You only need to traverse "to zero" and drill. Then the display shows the next position. The **graphic display** is a particularly useful feature: it lets you verify your input for the programmed bolt-hole pattern before machining.

With the **ND 1200R**, the positions of the holes are displayed as the distance remaining for the angular axis and radial arm.

If certain holes have to be machined for a second time, the ND 1200R remembers these positions at a keystroke. After ending the first operation, you can easily jump back to the positions concerned.

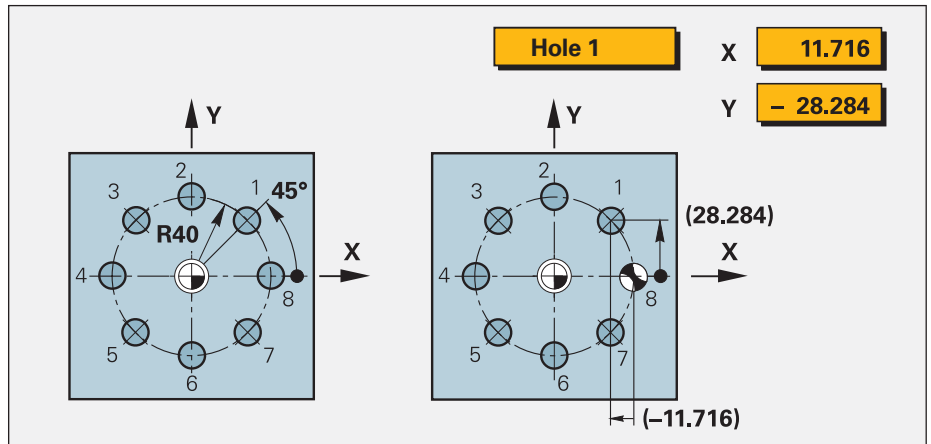

D:0 | T:1 | F: 0 | 0:00 | MM |

LINEAR PATTERN

TYPE: ARRAY

FIRST HOLE

X: 20.000

Y: 15.000

HOLES PER ROW: 4

ARRAY FRAME HELP

Select the pattern type (ARRAY or FRAME).

SINGLE CYCLE

T2: 4.5000 MM DRILL / Z | 0:00:00 | MM |

001	CYCL 1.0	DRILL
002	CYCL 1.1	NO. 1
003	CYCL 1.2	CK +0.000000
004	CYCL 1.3	CK +0.000000
005	CYCL 1.4	IMP +0.000000
006	CYCL 1.5	START 27.05.00
007	CYCL 1.6	DEPTH THRU

1 OF 7

HOLE 1 OF 8 Move to (X = 0.000, Y = 0.000). Drill Z to THRU. Press NEXT HOLE.

VIEW: (PGN/GRAPH) PREVIOUS HOLE NEXT HOLE END



Functions

- Contour monitoring (series ND 500, POSITIP)
- Rectangular pockets (POSITIP)

ND 500 series, POSITIP: Contour monitoring for overseeing manual 2-D operations

Particularly for 2-D milling and turning, the contour monitoring function shows you whether you are moving the tool near to the defined contour. The **POSITIP** supports it in an especially compatible way: it shows whether you are still within the tolerance limits that you have defined. The magnify function makes this possible even for relatively narrow tolerances while a second window provides you with an overall view of the workpiece.

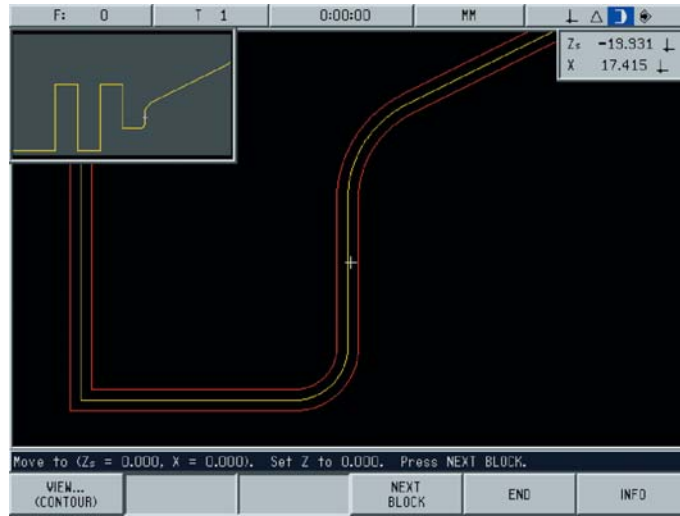

POSITIP: Milling and roughing-out rectangular pockets

The POSITIP aids you in milling and roughing out rectangular pockets. The digital readout calculates from your input the required positioning steps, and you simply position to the zero position value.

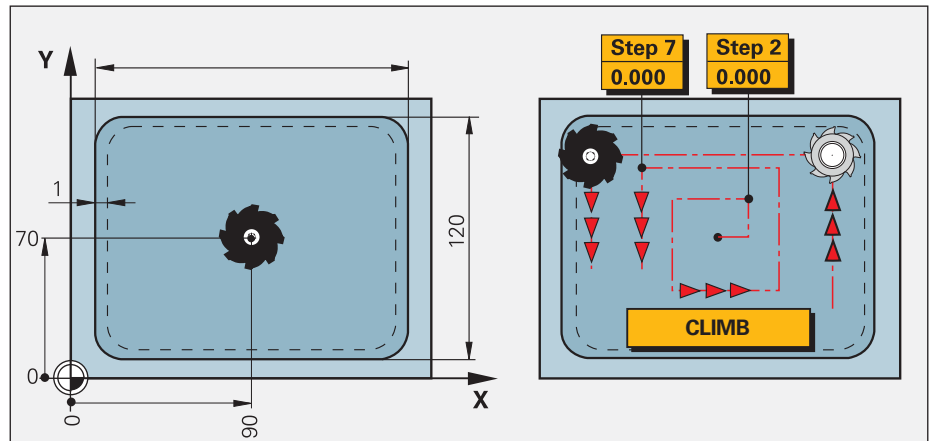

– Help when working with lathes (series ND 500, ND 780, POSITIP)

Radius/Diameter display

In the lathe mode, you can see the positions of the transverse axis in either radius or diameter values. You can switch at a keystroke.

Sum display of longitudinal axes

In lathe mode, the positions of the saddle and the top slide are displayed either separately or as the sum of both values.

- If you select separate displays, the position values are referenced to the datum for each individual axis. If only the saddle is moved, the displayed value for the top-slide axis remains unchanged.
- If sum display is selected, the counter adds both values while taking the algebraic sign into account. You can now read the absolute position of the tool in relation to the workpiece datum—without having to calculate!

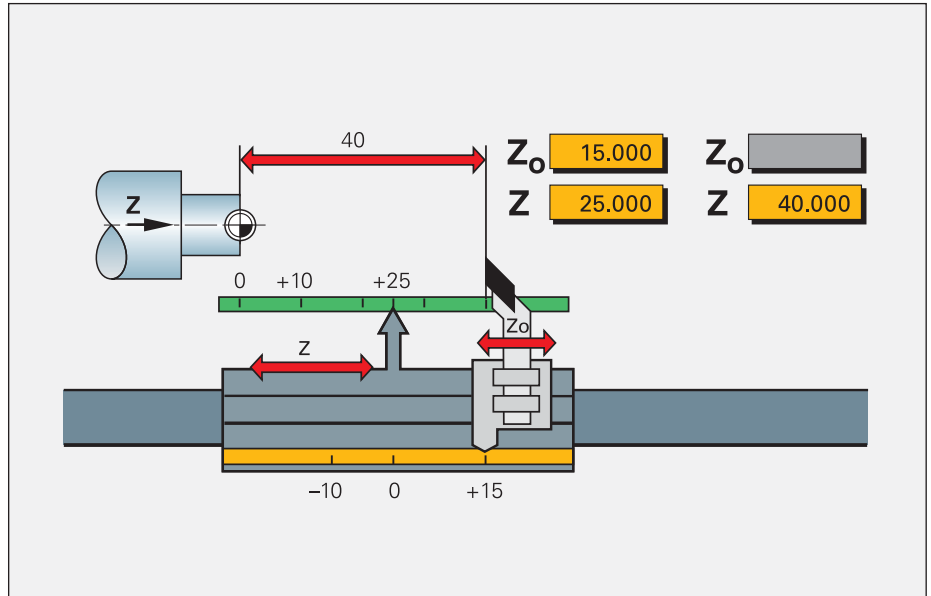

Taper turning made easy

If taper dimensions do not include the angle, the integrated taper calculator will help you with the calculation. Simply enter the taper ratio or the two diameters and the length. The correct angle for the top slide will be displayed immediately.

Turning

The POSITIP digital readout features a cycle for turning a shoulder in several passes. The distance remaining to the target position is shown both in the longitudinal and tool axes. You decide on the best infeed increment.

Constant surface speed

Particularly in taper turning or parting, the surface speed usually changes along with the diameter. But a constant surface speed is better for optimum machining results and long tool life. In conjunction with the output module IOB 49, the ND 780 digital readout therefore makes it possible to control workpiece rotation to ensure a constant surface cutting speed in spite of a changing workpiece diameter.

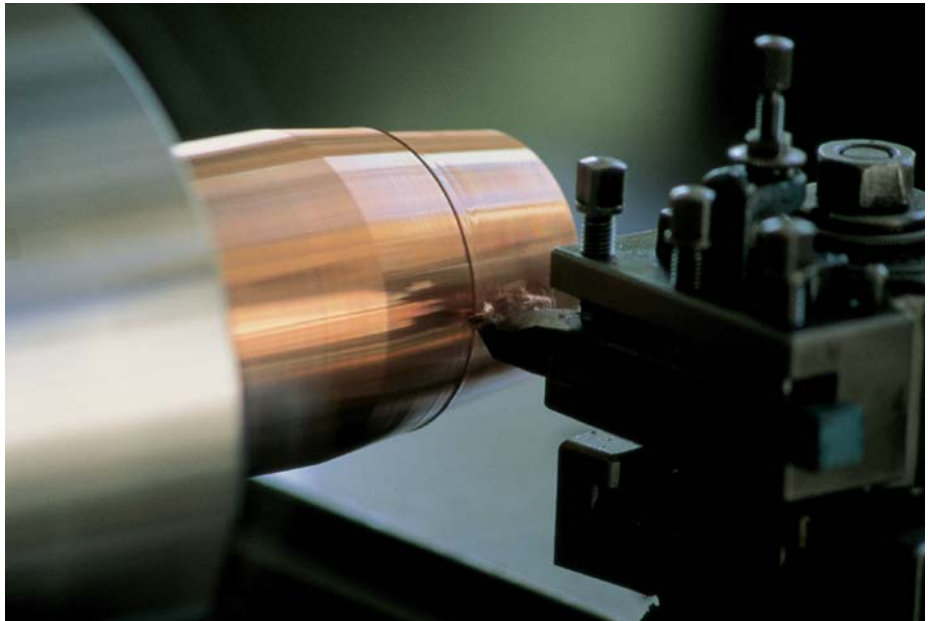

Functions

– Programming of machining steps (POSITIP, ND 1200 R)

The programming functions of POSITIP and ND 1200 R allow you to save repetitive machining steps as a program. Thus for example you can save all of the machining steps required as a program for a workpiece in a small-batch. In the Programming mode of operation, the distance-to-go display will guide you step-by-step to the programmed positions.

You can combine working steps into a program by either keying the program in step by step or by simply saving the actual positions while machining the first workpiece (teach-in programming).

POSITIP also allows you to generate program-section repeats and subprograms. If you are machining point patterns, you can program incremental positioning steps and then repeat them as often as necessary (program-section repeat). If you need to run the same program sequence at separate locations on the workpiece, you can write a subprogram and call it as needed. This saves you work at the keyboard and reduces inputting errors. Fixed cycles such as Bolt Hole Circle, Linear Hole Pattern or Rectangular Pocket (boring, milling) or Multipass (turning) keep your programs short and save you programming time. In the course of your work, the readout presents each nominal position in the proper sequence. You need only move from one position to the next.

With the **ND 1200 R** you can also save the hole diameter for each position; when you run the program later, RADIAL-DRILL displays the respective hole diameters for each position.

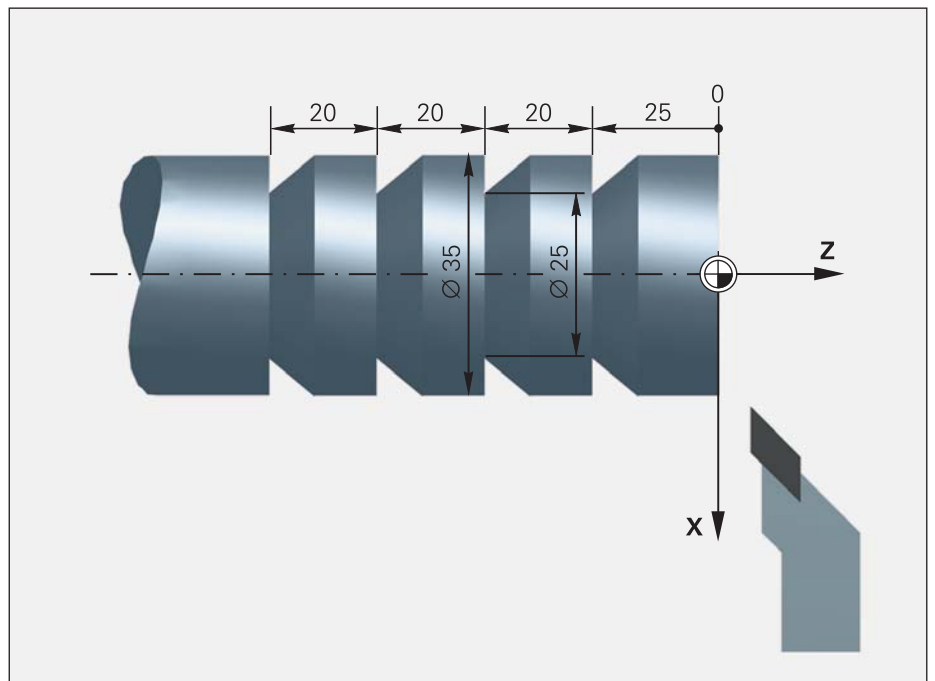
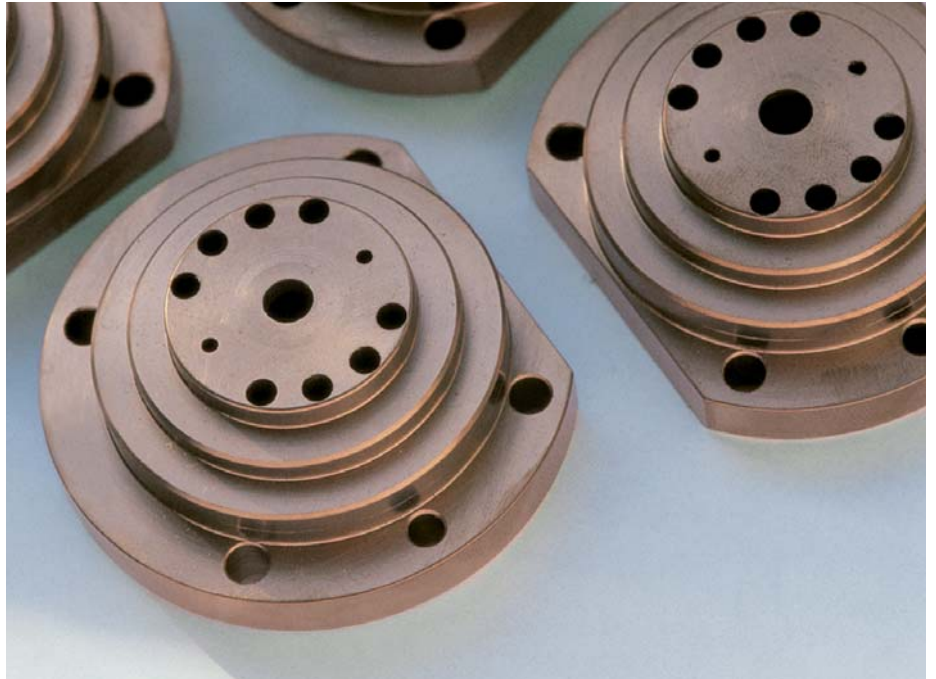

Example of a POSITIP program:
Turning several recesses on the same workpiece

000	BEGIN PGM 40 MM
001	X+80.000
002	Z+20.000
003	X+40.000
004	Z -5 000
005	LBL #8
006	IZ-20.000
007	X+25.000
008	X+40.000
009	CYCL 7.0 RPTLBL 8 3/3
010	CYCL 7.1 OUTZ +0.000
011	CYCL 7.2 OUTX +0.000
012	X+80.000
013	END PGM 40 MM

– For fast and conventional radial drills (ND 1200 R)

The special functions for **standard radial drills** (with moving drill head mounted laterally) and the **fast radial drills** (with drill head at end of radially moving arm) are integrated in the ND 1200 R RADIAL-DRILL readouts.

Coordinate transformation

You can switch between display in polar coordinates (radius R and angle A) and Cartesian coordinates (X, Y) at any time with a simple keystroke—even during positioning. You can also switch as desired between absolute or incremental dimension display.

Target Entry			
X	39,000	INC	1
Y	28,000	INC	1
D	0,000		
DRO			
		INC	Hole

Entry in Cartesian coordinates

Dist. from Trgt				MM	INC	P	---
R	74,620						
A	38°213						
DRO				X	39,000	Abs	✓
				Y	-28,000	Abs	
				Drill Size:	0,000		
Goto	Edit	INC	R/A	Menu			

Display of distance to go in polar coordinates

XY drilling coordinates

For positioning, the ND 1200 R automatically converts position values from polar coordinates to Cartesian coordinates. You enter the drawing's dimensions—absolute or incremental—directly as XY coordinates. RADIAL-DRILL calculates the path from the momentary position to the target position and shows you this remaining distance as separate values of the radial and angular axes, i.e. in machine coordinates. You position the tool head simply by moving to the display value zero: first you position the head to the radius display value zero and then you swing the arm until the angular display (A) is at zero.

It is advisable during positioning, however, that at least one of the axes can be clamped separately from the other.

Drill diameter

For every position you can save a drill diameter that is displayed when the position is next called.

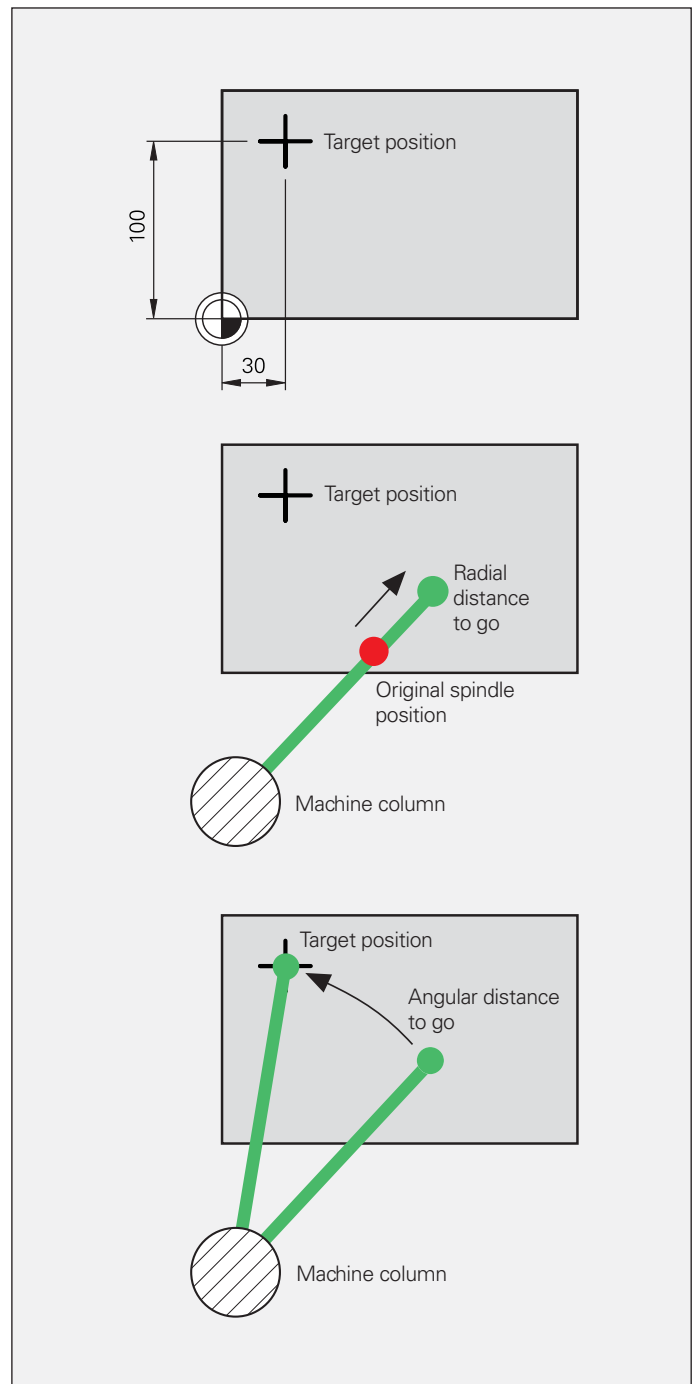

ND 280

– The digital readout for one axis

The ND 280 digital readout for one axis is designed for simple measuring and positioning tasks, such as infeed for a circular saw, the stroke of press travel, or the position of an additional rotary table on a machine tool.

Design

The ND 200 series features a sturdy aluminum die-cast housing. The splash-proof full-travel keyboard is built for the workshop. A large graphic TFT monitor displays the measured values, the status and the soft-key row.

Functions

The standard **ND 280** readout provides the basic functions for simple measuring and positioning tasks. The ND 287 evaluation unit (see catalog titled *Evaluation Electronics for Metrology Applications*) offers expanded functions such as metrological acquisition and statistical evaluation of measured values. With its switching inputs and outputs, it also permit operation in simple automated environments.

Data interfaces

The ND 280 has serial interfaces for measured value transfer to a PC or printer, for input/output of parameters and compensation value lists, and for diagnostics:

- USB (UART)
- RS-232-C/V.24



ND 280

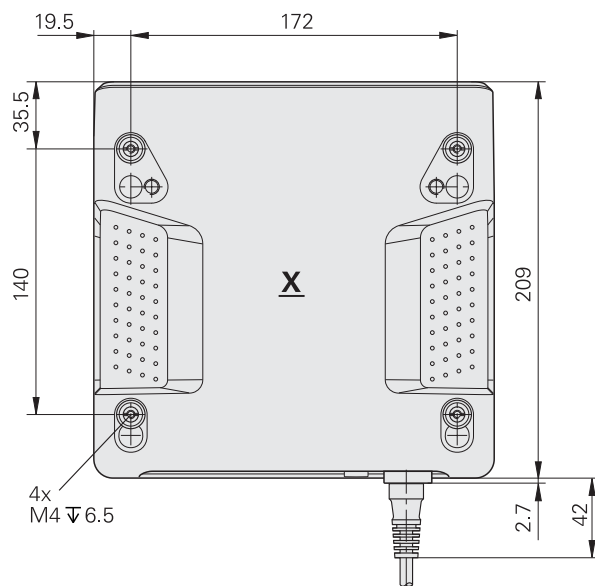
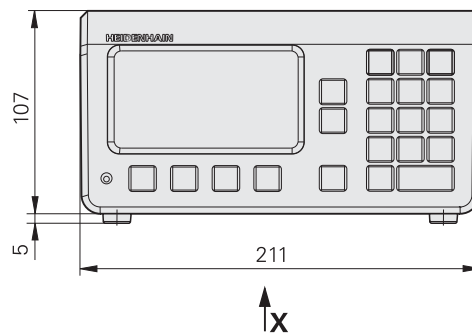

mm

 Tolerancing ISO 8015
 ISO 2768 - m H
 < 6 mm: ±0.2 mm

ND 280	
Axes	1
Encoder inputs	$\sim 1 V_{PP}$ $\sim 11 \mu A_{PP}$ or EnDat ¹⁾ : D-sub female 15-pin (automatic interface recognition)
Input frequency	$\sim 1 V_{PP}: \leq 500 \text{ kHz}; 11 \mu A_{PP}: \leq 100 \text{ kHz}$
Subdivision factor	4096-fold
Display step ²⁾	Adjustable, max. 9 digits <i>Linear axis:</i> 0.5 to 0.002 μm <i>Angular axis:</i> 0.5° to 0.000 01° or 00°00'00.1
Display	Monochrome TFT screen
	Position values, dialogs and input, graphic functions and soft keys
Status display	Operating mode, REF, datum, scaling factor, compensation, stopwatch, unit of measure, soft-key level
Functions	<ul style="list-style-type: none"> • REF reference-mark evaluation for distance-coded or single reference marks • 2 reference points • Distance-to-go mode • Integrated help and diagnostics • Remote operation via serial interface
Axis-error compensation	<i>Linear axis:</i> Linear and multipoint over up to 200 points <i>Angle axis:</i> Multipoint linear with 180 compensation points (every 2°)
Data interface	<ul style="list-style-type: none"> • RS-232-C/V.24 • USB (UART) port type B
Power connection	100 V to 240 V AC (-10 % to +15 %), 48 Hz to 62 Hz; 30 W
Operating temperature	0 °C to 45 °C (storage temperature -20 °C to 70 °C)
Protection EN 60529	IP 40, front panel IP 54
Weight	Approx. 2.5 kg

¹⁾ Purely serial, no evaluation of the incremental signals

²⁾ Depends on the signal period of the connected encoder (display step \approx signal period/4096)

ND 500 series

– Simple position display unit for two and three axes

The position displays of the ND 500 series are suited for use on manually operated milling, drilling, boring machines and lathes with two or three axes. Due to the TTL encoder input, primarily the LS 328 and LS 628 linear encoders with a measuring step of 5 µm are used.

Design

With its sturdy housing and splash-proof membrane keyboard, the ND 500 is built for the workshop. The ND 500 series shows display position values, the soft-key row and other useful information on a monochrome graphic screen.

Functions

The most important functions are available quickly and directly via function keys. Soft keys with clear information in the local language enable you to make entries that fit your momentary situation.

The **distance-to-go display** facilitates positioning tasks. You approach the next position quickly and reliably by simply moving until the display reads zero. The functions for each application are easily activated by parameter input. Special functions are available for producing **hole patterns** (linear patterns and circular patterns).

You can easily switch between radius and diameter display when the position display is configured for turning. On lathes with a separate top slide, the **sum display** feature of the ND 523 allows you to display the saddle and top slides together or separately. Setting datums on a lathe part is particularly easy with the **freeze tool position** function and subsequent retracting.

Data interfaces

A USB interface enables the digital readout to transfer measured values and import or export parameters and tables.



ND 523

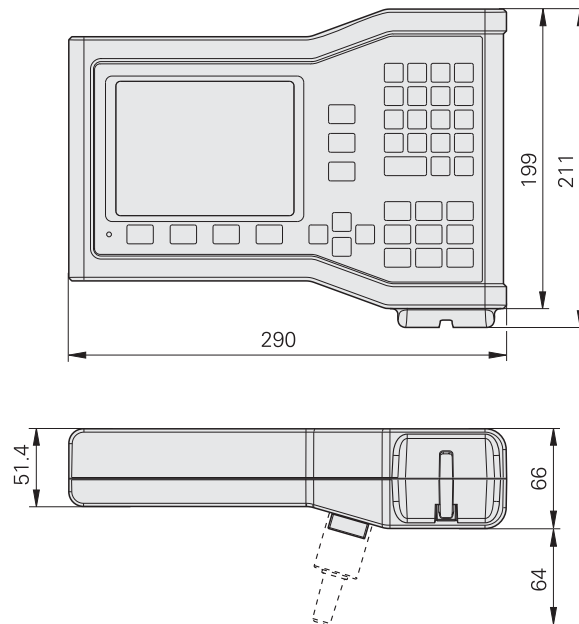

mm

 Tolerancing ISO 8015
 ISO 2768 - m H
 < 6 mm: ±0.2 mm

	ND 522	ND 523
Axes	2 axes from A to Z	3 axes from A to Z and Z _S
Encoder inputs	2 x □□TTL; D-sub female 9-pin	3 x □□TTL; D-sub female 9-pin
Input frequency	≤ 100 kHz	
Signal period	2 μm, 4 μm, 10 μm, 20 μm, 40 μm, 100 μm, 10240 μm, 12800 μm	
Line count	Any	
Evaluation	1/2/4-fold	
Display step¹⁾	<i>Linear axis:</i> 1 mm to 0.0001 mm; 0.005 with LS 328/LS 628 <i>Angular axis:</i> 1° to 0.0001° (00° 00' 01")	
Display	Monochrome flat screen for position values, dialog and input displays, graphic functions and graphic positioning support	
Status display	Operating mode, REF, reference-point number, tool number, inch, scale, feed-rate display, stopwatch	
For milling/drilling/boring	Tool compensation R+, R-	
For turning	Radius/Diameter display Separate or sum display for Z and Z _O	
Functions	<ul style="list-style-type: none"> • 10 reference points • 16 tools • REF reference mark evaluation for distance-coded and single reference marks • Distance-to-go display with nominal position input in absolute or incremental values • Contour monitoring • Scaling factor • mm/inch switching • HELP: On-screen operating instructions • INFO: Stopwatch, pocket calculator, cutting data calculator (for milling), taper calculator (for turning) 	
For milling/drilling/boring	<ul style="list-style-type: none"> • Calculation of positions for hole patterns (circular patterns as well as linear patterns) • Tool radius compensation 	
For turning	<ul style="list-style-type: none"> • Freezing the tool position for back-off 	
Error compensation	<i>Axis error:</i> Linear and multipoint over up to 200 points <i>Backlash compensation:</i> For length measurement via ball screw and rotary encoder	
Data interface	USB type B connector; 115 200 baud <ul style="list-style-type: none"> • For output of measured values and parameters • For input of parameters, remote control of keys and commands 	
Accessories	Tilting base, mounting arm	
Power connection	100 to 240 V AC (-15 % to +10 %), 48 Hz to 62 Hz; 54 W	
Operating temperature	0 °C to 45 °C (storage temperature -20 °C to 70 °C)	
Protection EN 60529	IP 40, front panel IP 54	
Weight	Approx. 2.6 kg	

¹⁾ Depends on the signal period or line count of the connected encoder

ND 780

– Adaptable readout for up to three axes

The ND 780 digital readout is especially suited for use on milling, drilling and boring machines and lathes with up to three axes. A separate I/O unit provides switching input/outputs for simple tasks in automation.

Design

The ND 780 digital readout is designed as a sturdy upright unit with splash-proof full-travel keypad for use in a workshop. It is equipped with a monochrome flat screen for position values, dialog and input displays, graphic functions and graphic positioning support.

Functions

The **ND 780** readout is characterized by its plain language dialog guidance. The **distance-to-go display** facilitates positioning tasks. You approach the next position quickly and reliably by simply moving until the display reads zero. The functions for each application are easily activated by parameter input. Special functions are available for producing **hole patterns** (linear patterns and circular patterns). Datums can be determined quickly and accurately with an edge finder. The ND 780 readout supports you with special **probing functions**.

You can easily switch between radius and diameter display when the position display is configured for turning. The readout also offers support for lathes with separate top slide: The **sum display feature** allows you to display the saddle and top slides together or separately. To set a datum, simply touch the workpiece and **freeze the tool position**. Then retract and measure workpiece with the tool out of the way.

Data interfaces

The ND 780 has an RS-232-C/V.24 serial interface for measured value transfer to a PC or printer, for input/output of parameters and compensation value lists, and for diagnostics.

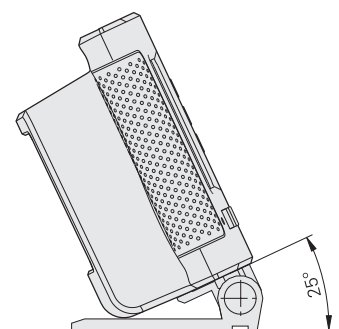
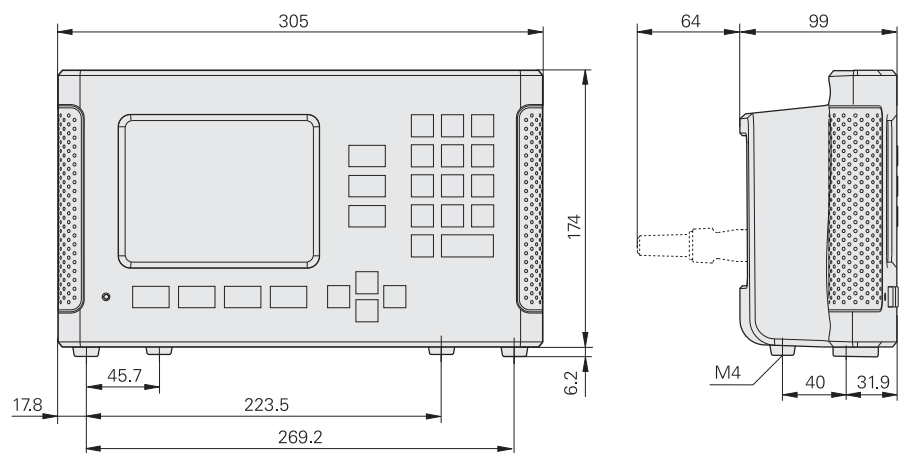

mm

Tolerancing ISO 8015
ISO 2768 - m H
< 6 mm: ±0.2 mm

ND 780	
Axes	Up to 3 axes from A to Z and Z ₀ , Z _S
Encoder inputs	3 x \sim 1 V _{PP} or \sim 11 μ A _{PP} ; D-sub female 15-pin (automatic interface recognition)
Input frequency	\leq 100 kHz
Signal period	2 μ m, 4 μ m, 10 μ m, 20 μ m, 40 μ m, 100 μ m, 10240 μ m, 12800 μ m
Line count	Any
Subdivision factor	Max. 1024-fold
Display step¹⁾	<i>Linear axis:</i> 1 mm to 0.0001 mm <i>Angular axis:</i> 1° to 0.0001° (00° 00' 01")
Display	Monochrome flat screen for position values, dialog and input displays, graphic functions and graphic positioning support
Status display	Operating mode, REF, reference-point number, tool number, inch, scale, feed-rate display, stopwatch
For milling/drilling/boring	Tool compensation R+, R-
For turning	Radius/Diameter display Separate or sum display for Z and Z ₀
Functions	<ul style="list-style-type: none"> • 10 reference points • 16 tools • REF reference mark evaluation for distance-coded and single reference marks • Distance-to-go display with nominal position input in absolute or incremental values • Scaling factor • mm/inch switching • HELP: On-screen operating instructions • INFO: Stopwatch, pocket calculator, cutting data calculator (for milling), taper calculator (for turning)
For milling/drilling/boring	<ul style="list-style-type: none"> • Calculation of positions for hole patterns (circular patterns as well as linear patterns) • Tool radius compensation • Probing function for datum acquisition with the KT edge finder: "Edge," "Centerline" and "Circle center"
For turning	<ul style="list-style-type: none"> • Freezing the tool position for back-off • Setup functions for datum setting with the tool
Error compensation	<i>Axis error:</i> Linear and multipoint over up to 200 points <i>Backlash compensation:</i> For length measurement via ball screw and rotary encoder
Data interface	RS-232-C/V.24 300 to 115 200 baud <ul style="list-style-type: none"> • For output of measured values and parameters • For input of parameters, remote control of keys and commands
Switching I/O	<ul style="list-style-type: none"> • Two inputs (pulse or contact) for measured value output • 1 input for KT edge finder • 1 input for edge finder with contact triggering • Further input/outputs over the IOB 49 input/output unit
Accessories	KT edge finder (for milling) tilting base, handle, tilt/swivel mount, pivot arm
Power connection	100 to 240 V AC (-15 % to +10 %), 48 Hz to 62 Hz; 30 W
Operating temperature	0 °C to 45 °C (storage temperature -20 °C to 70 °C)
Protection EN 60529	IP 40, front panel IP 54
Weight	Approx. 2.6 kg

¹⁾ Depends on the signal period or line count of the connected encoder

POSITIP 880

– The programmable readout for up to six axes

The POSITIP 880 is a versatile display unit designed primarily for milling machines, drilling and boring machines and lathes with up to six axes. A separate I/O unit provides switching input/outputs for simple tasks in automation.

Design

The POSITIP 880 is designed as a sturdy upright unit with splash-proof full-travel keypad for use in the workshop. It supports all operations with straightforward interactive menus on its large, easy-to-read color flat screen.

Functions

The POSITIP provides advanced features beyond those offered by the ND 780 digital readout. The POSITIP supports any axis combination and helps you at 2-D machining operations with its graphic contour monitoring and magnify function. In the milling mode, it supports you in machining and clearing out rectangular pockets while it takes allowances into account during turning.

The programming capabilities of POSITIP make it ideal for small-batch production on conventional machine tools: you can store up to 999 program blocks per program in its memory. Programs are created by either keying them in step by step or generating them through actual position capture (teach-in programming). With the subprogramming capability, you can enter repetitive machining sequences on the same workpiece once only. Fixed cycles keep your programs short and save you programming time.

Data interfaces

The POSITIP 880 has an RS-232-C/V.24 serial interface for measured value transfer to a PC or printer, for input/output of parameters and compensation value lists, and for diagnostics.

A parallel Centronics interface is also provided for pure measured value output.

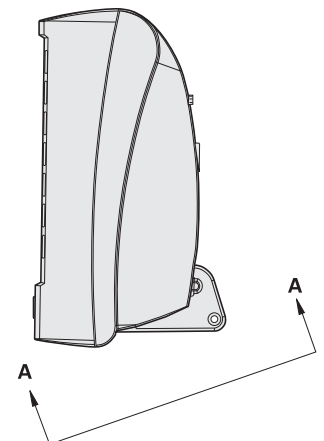
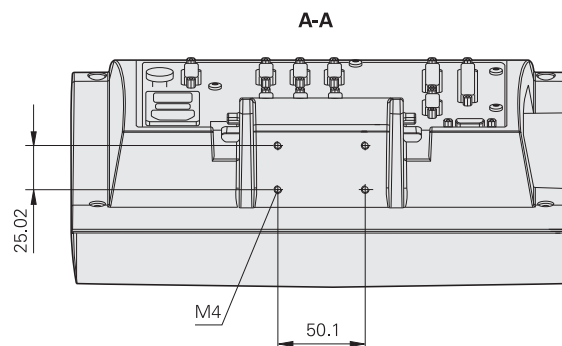
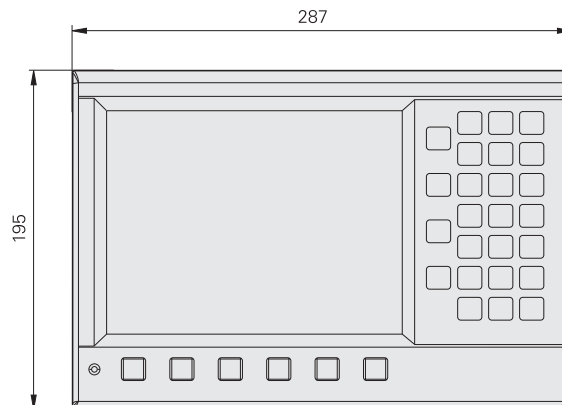

mm

 Tolerancing ISO 8015
 ISO 2768 - m H
 < 6 mm: ±0.2 mm

		POSITIP 880
Axes		Up to 6 axes from A to Z and Z ₀ , Z _S
Encoder inputs		6 x $\sim 1 V_{PP} \sim 11 \mu A_{PP}$ or EnDat 2.1; D-sub female 15-pin (automatic interface recognition)
Input frequency		≤ 100 kHz
Signal period		0.128 μm, 2 μm, 4 μm, 10 μm, 20 μm, 40 μm, 100 μm, 10240 μm, 12800 μm
Line count		Any
Subdivision factor		Max. 1024-fold
Display step¹⁾		<i>Linear axis:</i> 1 mm to 0.005 μm <i>Angular axis:</i> 0.01° to 0.0001° (00° 00' 01")
Display		Color flat screen for position values, dialog and input displays, graphic functions, graphic positioning support and contour monitoring
Status display		Operating mode, REF, reference-point number, tool number, inch, scale, feed-rate display, stopwatch
For milling/drilling/boring		Tool compensation R+, R-
For turning		Radius/diameter display; separate or sum display for Z and Z ₀
Functions		<ul style="list-style-type: none"> • REF reference-mark evaluation for distance-coded or single reference marks • Distance-to-go mode, nominal position input (absolute or incremental) • Scaling factor • Contour monitoring with magnify function • Any axis combinations • HELP: On-screen operating instructions • INFO: Stopwatch, pocket calculator, cutting data calculator (for milling), taper calculator (for turning)
For milling/drilling/boring		<ul style="list-style-type: none"> • 99 datums and 99 tools • Calculation of positions for hole patterns (circular patterns as well as linear patterns) • Tool radius compensation • Probing function for datum acquisition with the KT edge finder: "Edge," "Centerline" and "Circle center" • Positioning aids for milling and the roughing out of a rectangle pocket
For turning		<ul style="list-style-type: none"> • 1 reference point, 99 tools • Freezing tool position for back-off • Oversize allowances
Programming		Up to 999 program blocks per program; sub programming capability with turning and mirroring; teach-in programming
Cycles	For milling/drilling For turning	Lines, arcs, chamfers, circle patterns, linear patterns and rectangle pockets Line segments, circular arcs, chamfers, multipass
Error compensation		Linear and multipoint, up to 128 measuring points
Interfaces places	Serial Parallel	RS-232-C/V.24 300 to 115 200 baud <ul style="list-style-type: none"> • For output of programs, measured values and parameters • For loading of programs and parameters Centronics for output of measured values
Switching I/O		<ul style="list-style-type: none"> • Via IOB 89 external input/output unit • 1 input for KT edge finder
Accessories		KT edge finder (milling) tilting base, tilt/swivel mount, pivot arm
Power connection		100 V to 240 V AC (-5 % to +10 %), 48 Hz to 62 Hz; 35 W
Operating temperature		0 °C to 45 °C (storage temperature -20 °C to 70 °C)
Protection EN 60529		IP 40, front panel IP 54
Weight		Approx. 3.2 kg

¹⁾ Depends on the signal period or line count of the connected encoder

ND 1200R RADIAL-DRILL digital readout

Digital readouts for conventional and fast radial drilling machines

The ND 1200R RADIAL-DRILL digital readout is an easily operated, powerful position readout for conventional and fast radial drilling machines. Machine movement is measured by a linear encoder on the radial arm and a rotary encoder or a friction-wheel system on the column. An additional encoder on the sleeve can also be used to measure and display the drilling depth.

Design

The ND 1200R RADIAL-DRILL digital readout features a sturdy housing of die-cast aluminum and a splash-proof full-travel keyboard. The monochrome flat-panel graphic display shows position values, plain language dialog and prompts as well as graphic functions.

Functions

With the ND 1200R digital readout, you can switch at any time between display in **polar coordinates** (radius R, angle α) and **Cartesian coordinates** (X, Y). With the aid of the **probing functions** you'll find the workpiece datum and orientation faster. One essential working aid is the function for positioning with the **distance-to-go display**: You type in the nominal position—i.e. the drilling coordinates—as X,Y values; the RADIAL-DRILL digital readout shows you the distance remaining to the target position as separate values for the angular and radial axes, which are therefore the machine coordinates. The ND 1200R automatically calculates the positions when machining **hole patterns** such as bolt-hole circles and linear hole patterns, matrices or frames. The **programming function** of the ND 1200R supports you when machining recurring workpieces and machining patterns.

Interfaces

The RS-232-C/V.24 and USB serial interfaces serve for saving programs and updating software.

Equipping a radial drill

The angular position of the radial arm is usually measured with a rotary encoder and friction wheel system or—for higher accuracy requirements—with an ROD angle encoder or rotary encoder. The drill head position and, if required, the spindle stroke are measured with LS linear encoders. The KT edge finder serves for an exact calibration of the machine and, if desired, to set up the workpiece.

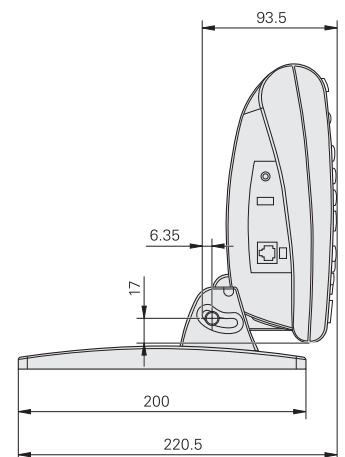
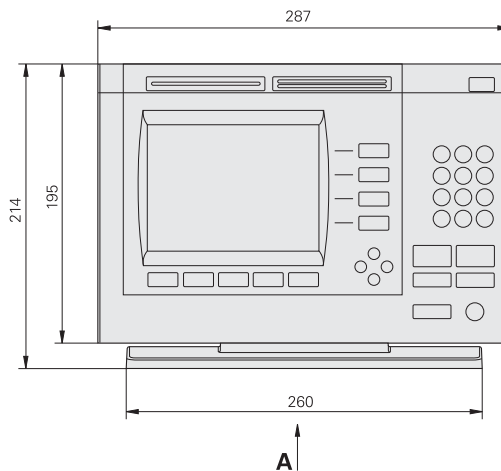
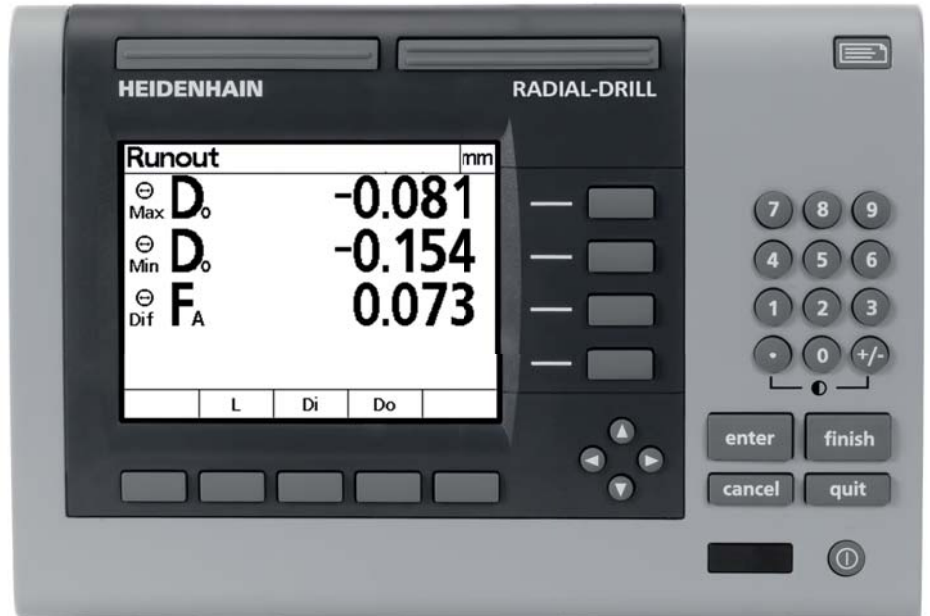

ND 1200R with tilting base

mm

 Tolerancing ISO 8015
 ISO 2768 - m H
 < 6 mm: ±0.2 mm

	ND 1202R	ND 1203R
Axes	2 from A to Z	3 from A to Z
Encoder inputs*	□□ TTL (D-sub female 9-pin) or \sim 1 V _{PP} (D-sub female 15-pin)	
Input frequency	≤ 200 kHz	
Signal period	Any	
Line count	Any	
Subdivision factor	□□ TTL: Max. 4-fold \sim 1 V _{PP} : Max. 40-fold	
Display step ¹⁾	Adjustable, max. 7 digits	
Display	5.7" monochrome flat-panel display for position values, dialogs and inputs, and soft keys	
Functions	<ul style="list-style-type: none"> • Conversion of Cartesian coordinates (X,Y) to polar coordinates (R,A) • XY/RA switch-over • Alignment function • REF reference-mark evaluation for distance-coded or single reference marks • Distance-to-go display in machine coordinates R and A • mm/inch switching • Absolute-incremental display • Calculation of positions for hole patterns (circular patterns as well as linear patterns) • Probing functions for workpiece orientation and reference-point acquisition with KT edge finder: "Edge," "Centerline" and "Circle center" 	
Programming	Hole patterns with a total of 999 hole positions	
Cycles	Hole patterns (circular and linear patterns) with max. 100 positions	
Error compensation	Linear axis-error compensation as part of calibration	
Data interface	<ul style="list-style-type: none"> • RS-232-C/V.24; 300 to 115 200 baud • USB type A 	
Switching inputs	<ul style="list-style-type: none"> • Zero reset, measured value output (e.g. by foot switch) • Edge finder (through universal touch probe interface) 	
Accessories	Mounting arms, KT-130 edge finder, foot switch	
Power connection	100 V to 240 V AC (-15 % to +10 %), 47 Hz to 63 Hz; 30 W	
Operating temperature	0 °C to 45 °C (storage temperature -20 °C to 70 °C)	
Protection EN 60529	IP 40	
Mounting*	Tilting base or mounting base	
Weight	Approx. 1.6 kg	

* Please select when ordering

¹⁾ Depends on the signal period of the connected encoder as well as the subdivision factor

Mounting

– ND 200 and ND 500 series

ND 200 series

The ND 200 series digital readouts were conceived as bench-top units. They can easily be stacked. Recesses on the top prevent the stacked units from moving out of place.

You can secure the ND 28x from below by using M4 screws on a base plate.

Two ND 28x readouts fit next to each other in a 19" housing. A mounting adapter is available as an accessory for mounting in a 19" housing.

Accessory:

Mounting adapter for 19" housing
ID 654020-01

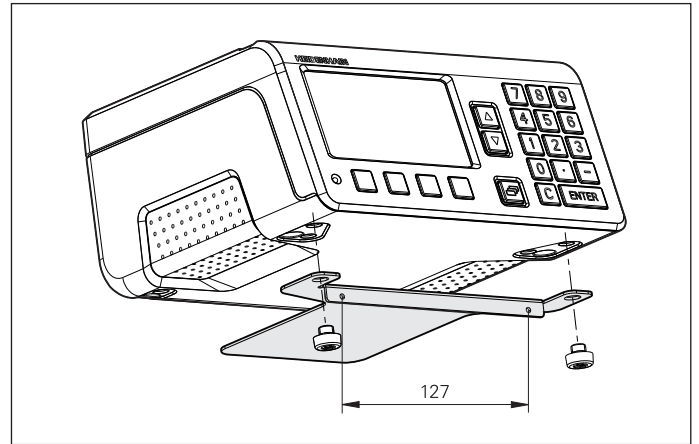

ND 500 series

You can set up the ND 52x either on a mounting arm on the machine, with the aid of a mounting base, or install it in a control panel. The parts required for fastening the display are included in delivery. They enable you to rotate and tilt the display. The mounting arm, mounting base, and mounting frame are available as accessories:

Accessory:

Mounting arm, straight (see page 29)
ID 382893-01

Mounting arm, offset (see page 29)
ID 382929-01

Mounting stand
ID 625491-01

Mounting frame
ID 647702-01

For mounting the ND 52x in a housing or operating panel.

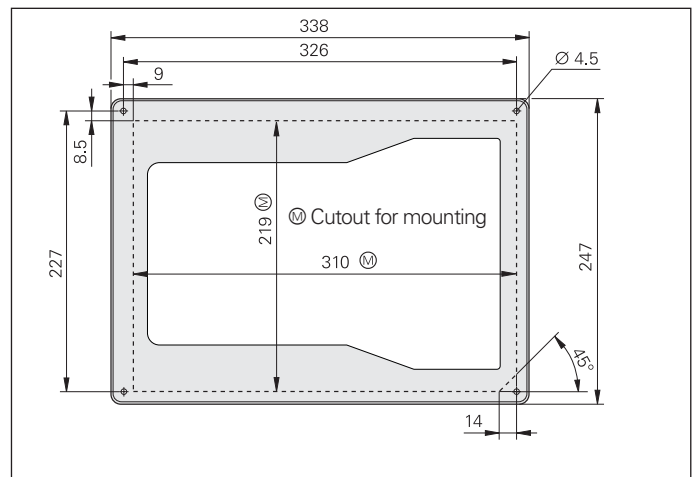
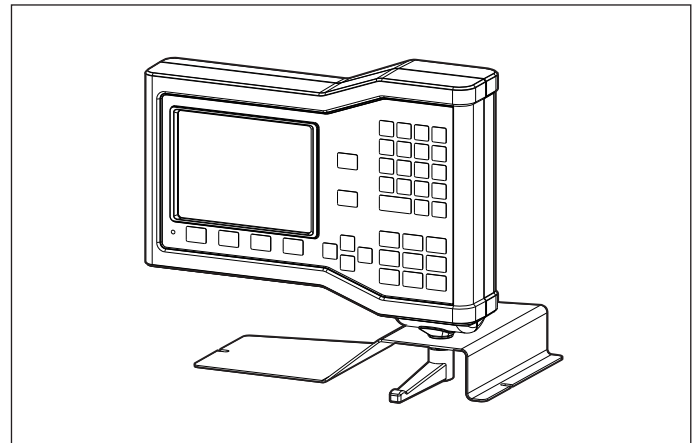

– ND 780

The ND 780 display units were conceived as upright units. There are several possible mounting configurations:

- M4 threaded mounting hole on bottom of housing
- Tilting base
- Mounting frame
- Tilt/swivel assembly
- Mounting arm and tilt/swivel assembly

Accessories

Tilting base

ID 281619-01

The tilting base can be used to tilt the display forward and backward by up to 20°. It can be attached with M5 screws.

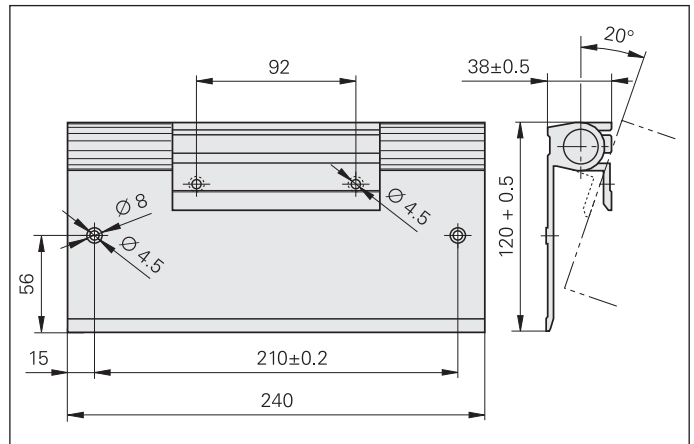

Tilt/swivel assembly

ID 520011-01

The joint permits tilting and rotation of the readout. It can be attached to a machine element or mounting arm with its M8 screws.

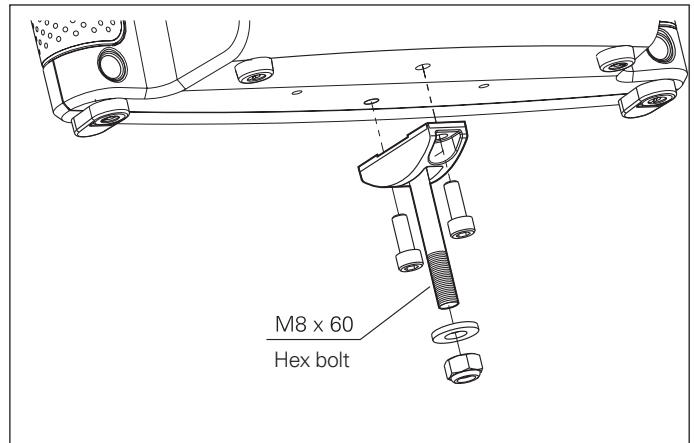

Grip bar

ID 520012-01

The grip bar is attached to the base of the ND 780, and is used to easily swivel the readout.

Mounting arm, straight (see page 29)

ID 382893-01

Mounting arm, offset (see page 29)

ID 382929-01

Mounting frame

ID 532811-01

For mounting the ND 780 in a housing or operating panel.

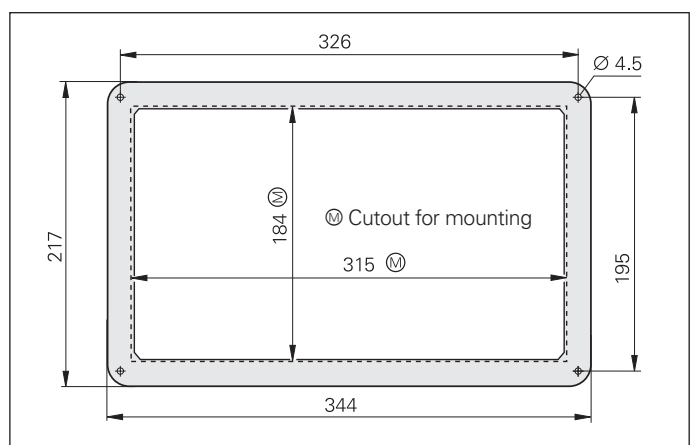

Mounting

– POSITIP 880

The POSITIP 880 was conceived as an upright unit. There are several possible mounting configurations:

- M4 threaded mounting hole on bottom of housing
- Tilting base
- Tilt/swivel assembly
- Mounting arm and tilt/swivel assembly

Accessories

Tilting base

ID 382892-01

It can be used to tilt the display forward and backward by up to 20°. It can be attached with M5 screws.

Tilt/swivel assembly

ID 382891-01

The joint permits tilting and rotation of the readout. It can be attached to a machine element or mounting arm with its M8 screws.

Mounting arm, straight (see page 29)

ID 382893-01

Mounting arm, offset (see page 29)

ID 382929-01

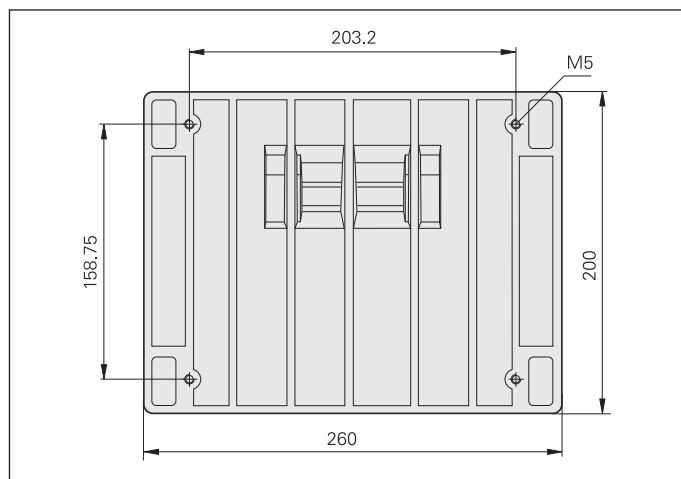
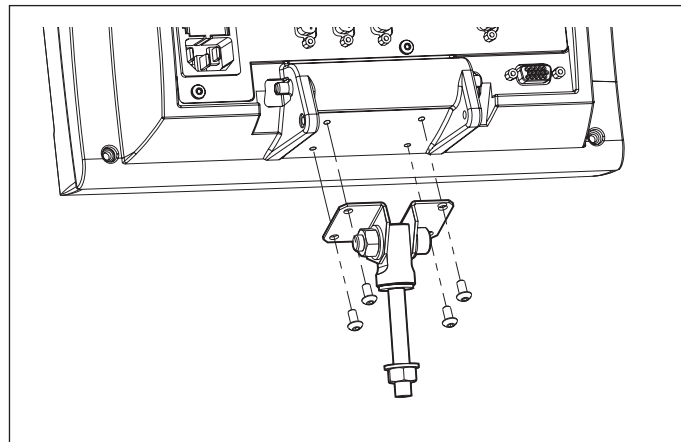

– Mounting arms (accessories for series ND 500, ND 780, POSITIP)

You can use the mounting arm to easily place the display at a conveniently operable position. It can be attached to the machine and swiveled by either a bracket or a hex bolt. The display is attached to the mounting arm via its own tilt/swivel mount.

Accessory:

Mounting arm, straight

ID 382893-01

Mounting arm, offset

ID 382929-01

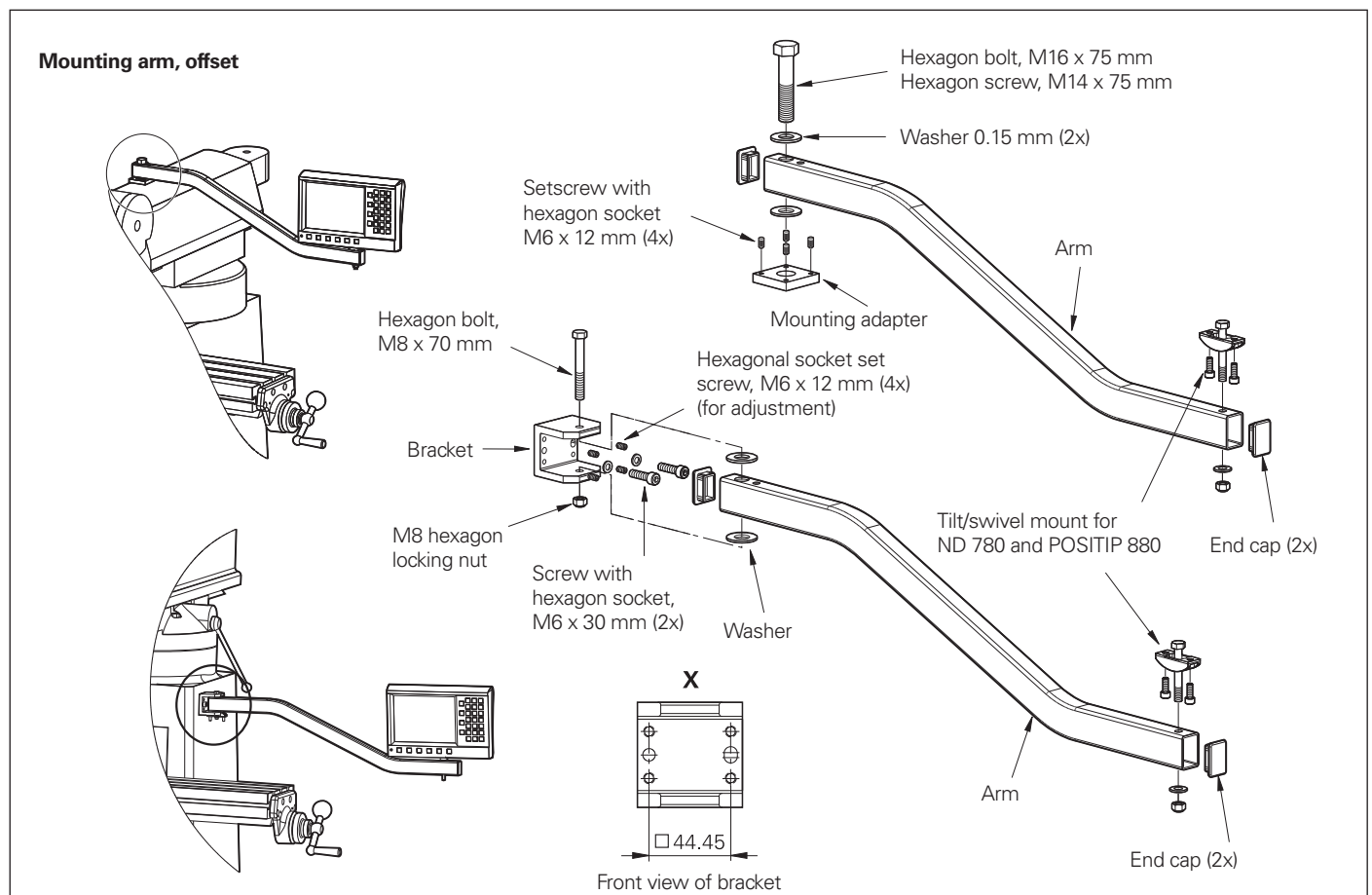
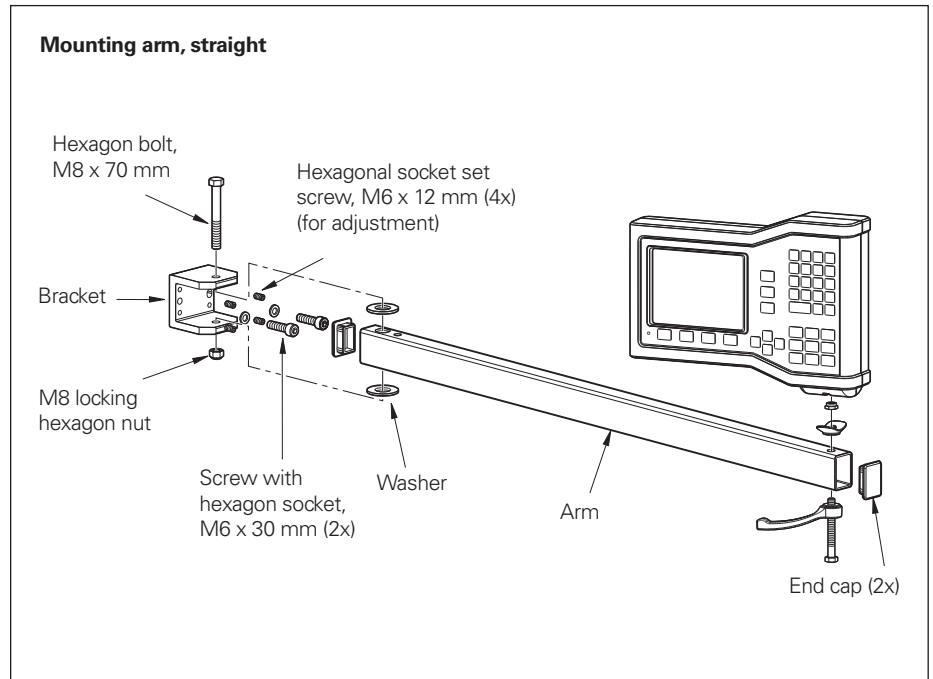

Mounting

Mounting and protection of ND 1200 R

Assembly

The ND 1200 R is shipped with either a tilting base or a mounting adapter.

Mounting stand

The readout can be used as a tabletop unit when placed on the tilting base. The readout can then be tilted forward or backward by up to 20° for the best reading angle. The tilting base can be attached with M5 screws.

ID 382892-02

Mounting adapter

The mounting adapter is used to attach the ND 1200 R to a mounting arm or directly to the machine. It also enables the user to tilt the readout.

ID 682419-01

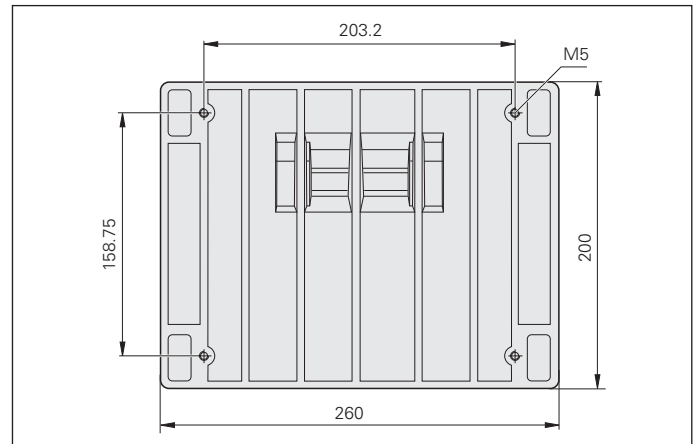

Mounting adapter

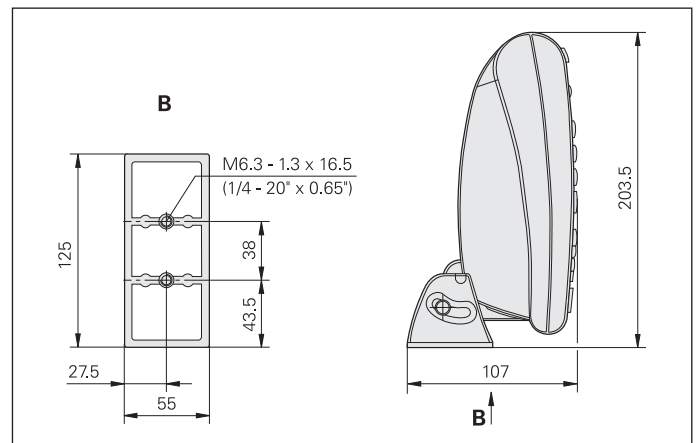

Protective cover (accessory)

Protective covers are available as accessories for keeping the keyboard and screen of the ND 1200R from becoming soiled. The display can still be easily read through the transparent protective covers. They fit themselves optimally to the front of the unit, without impairing the ease of operation.

ID 681051-03



Encoders

Connectable encoders

Linear and angle encoders from HEIDENHAIN with various interfaces can be connected to HEIDENHAIN digital readouts (see table).

Connecting a linear or angle encoder

HEIDENHAIN linear and angle encoders can be connected easily and directly to the digital readouts.

The versatile readouts from HEIDENHAIN can be adapted to the encoder and the respective operating conditions. The following values can be set via parameters:

- Signal period of the linear encoder
- Line count of the angle or rotary encoder
- Desired display step (resolution)
- Counting direction
- Angle display, etc.

Specifics of connecting rotary encoders

Rotary encoders can also be connected to the display units in order to measure linear distances via spindle and rotary encoder combinations, or for measuring angles on rotary tables with worm gears. It must be taken into consideration that the errors of the mechanical transfer elements (spindle-pitch error, reversal error, etc.) directly influence the positioning accuracy. The traverse distance and the display value can be adjusted to each other in the position display unit. With the POSITIP, you can also enter an additional factor (reduction gear).

Signal period of lead-screw/rotary-encoder combination for linear measurement

Spindle pitch: 10 mm

Line count of the encoder: 1000 lines

Theoretical signal period:

$10 \text{ mm} : 1000 \text{ lines} = 0.01 \text{ mm} = 10 \text{ }\mu\text{m}$

Line count for angular measurement with rotary encoder via a worm gear

Gear ratio 9 : 1

Line count of the encoder:

e.g. 1000 lines

Theoretical line count for angular measurement (any value possible):

$9 \times 1000 \text{ lines} = 9000 \text{ lines}$

Type	Connectable encoders	Interface	Connecting elements Encoder input
ND 280 ND 287	Incremental linear, angle or rotary encoders	$\sim 1 \text{ V}_{PP}$ $\sim 11 \text{ }\mu\text{A}_{PP}$	D-sub connector (female), 15-pin
	Absolute linear, angle or rotary encoders	EnDat 2.1/2.2 (without incremental signals)	
ND 522 ND 523	Incremental linear and angle encoders	\square TTL	D-sub connector (female) 9-pin
ND 780	Incremental linear and angle encoders	$\sim 1 \text{ V}_{PP}$ $\sim 11 \text{ }\mu\text{A}_{PP}$	D-sub connector (male), 15-pin
POSITIP 880	Incremental linear, angle or rotary encoders	$\sim 1 \text{ V}_{PP}$ $\sim 11 \text{ }\mu\text{A}_{PP}$	D-sub connector (male), 15-pin
	Absolute linear, angle or rotary encoders	EnDat 2.1	
ND 1202R ND 1203R	Incremental linear, angle or rotary encoders	$\sim 1 \text{ V}_{PP}$	D-sub connector (male), 15-pin
		\square TTL	D-sub connector (female) 9-pin

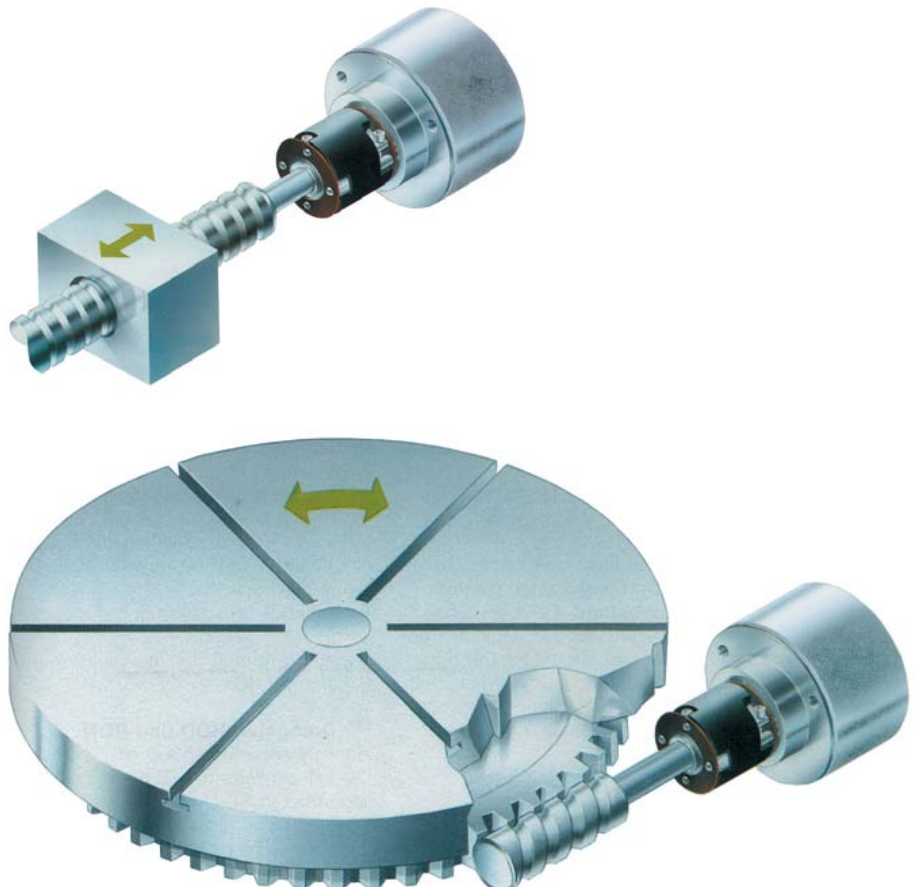

Encoders

Absolute encoders

With absolute encoders from HEIDENHAIN, the position value is available from the encoder immediately upon switch-on, and can be called at any time by the readout. There is no need to move the axes to find the reference position. The absolute position information is read directly from the scale graduation and is output serially as an absolute position value via the bidirectional EnDat interface.

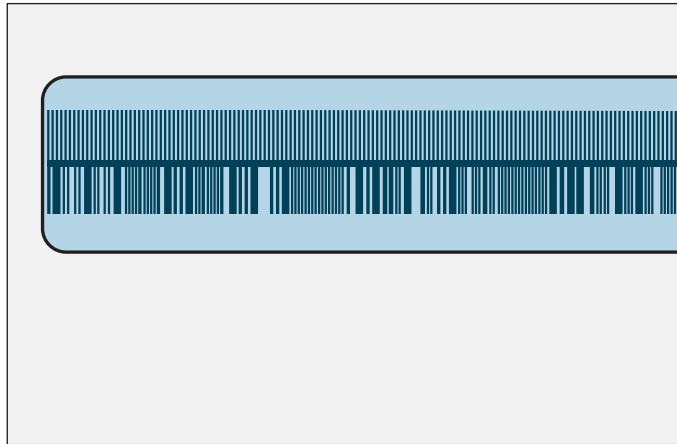

Incremental encoders

Incremental linear and angle encoders from HEIDENHAIN output two sinusoidal signals phase-shifted by 90° as measuring signals, as well as one or more reference mark signals. The readout often subdivides the sinusoidal measuring signal in order to attain measuring steps smaller than the signal period.

Incremental measurement means measuring by counting. In order to attain an absolute reference, a **reference mark** is applied to the scale. When the reference mark is scanned, a signal associated with exactly one measuring step is generated. In this manner, the association between the position and the display value specified by the **datum setting** is re-established by scanning the reference marks in each axis.

To speed and simplify the referencing procedure, many HEIDENHAIN scales (and graduated disks of angle encoders) have distance-coded reference marks. On these position encoders, the absolute position is already available after scanning two neighboring reference marks. For example, on linear encoders this distance is at most 20 mm (LS, LF) or 80 mm (LB), and for angle encoders a rotation of at most 20°.

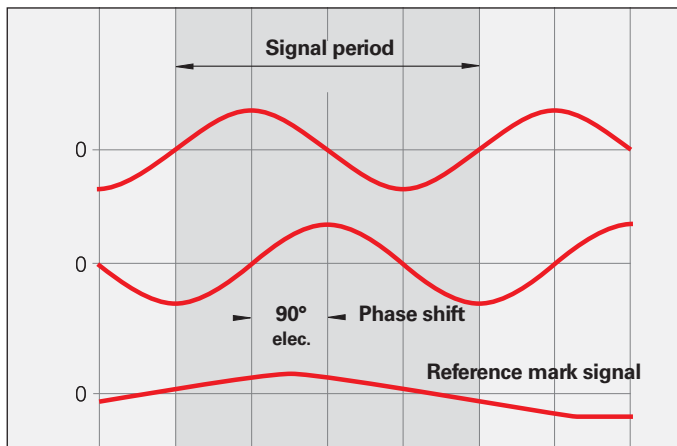



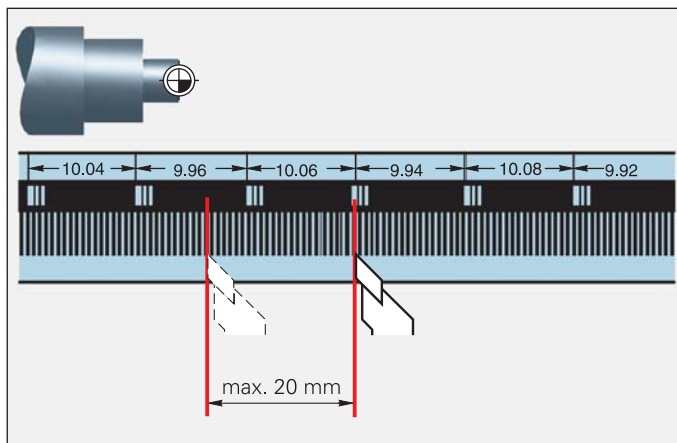





Sinusoidal measuring signals



Traverse with distance-coded reference marks

Interfaces

Digital readouts feature interfaces for encoders, for communication and external operation.



	ND 280	ND 522 ND 523	ND 780	POSITIP 880	ND 1200R
Encoders	 1 V _{PP}  11 μA _{PP} EnDat ¹⁾	 TTL	 1 V _{PP}  11 μA _{PP}	 1 V _{PP}  11 μA _{PP} EnDat 2.1	 1 V _{PP}  TTL
Edge Finder	–	–	<ul style="list-style-type: none"> • KT 130 • Contact triggering 	KT 130	KT 130
Data	<ul style="list-style-type: none"> • RS-232-C/V.24 • USB (UART) 	USB	RS-232-C/V.24	<ul style="list-style-type: none"> • RS-232-C/V.24 • Centronics 	<ul style="list-style-type: none"> • RS-232-C/V.24 • USB (UART)
Switching inputs	–	–	4 (over IOB 49 input/output unit)	8 (over IOB 89 input/output unit)	For foot switch
Switching outputs	–	–	9 (over IOB 49 input/output unit)	9 (over IOB 89 input/output unit)	–
Analog output	–	–	1 (over IOB 49 input/output unit)	–	–

¹⁾ Purely serial, no evaluation of the incremental signals

Interfaces

– Encoders

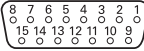
Pin layout of series ND 200 $\sim 1 V_{PP}/\sim 11 \mu A_{PP}/EnDat$



15-pin D-sub flange socket (female)  															
	Power supply					Incremental signals						Absolute position values			
	4	12	2	10	6	1	9	3	11	14	7	5	13	8	15
$\sim 1 V_{PP}$	U_P	Sensor U_P	0V	Sensor 0V	/	A+	A-	B+	B-	R+	R-	/	/	/	/
$\sim 11 \mu A_{PP}$					Internal shield	I ₁₊	I ₁₋	I ₂₊	I ₂₋	I ₀₊	I ₀₋	/	/	/	/
EnDat						/	/	/	/	/	/	DATA	DATA	CLOCK	CLOCK

Shield on housing; U_P = power supply voltage

Sensor: The sensor line is connected in the encoder with the corresponding power line.

Vacant pins or wires must not be used!

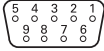

Pin layout of the ND 500 series $\square \sqcup$ TTL

9-pin D-sub flange socket (female)  									
	Power supply		Incremental signals						Others
	7	6	2	3	4	5	8	9	1
$\square \sqcup$ TTL	U_P	0V	U_{a1}	\overline{U}_{a1}	U_{a2}	\overline{U}_{a2}	U_{a0}	\overline{U}_{a0}	/

Shield on housing; U_P = power supply voltage

Vacant pins or wires must not be used!

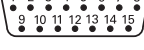
Pin layout **ND 780** $\sim 1 V_{PP}/\sim 11 \mu A_{PP}$ **PT 880** $\sim 1 V_{PP}/\sim 11 \mu A_{PP}/EnDat$



15-pin D-sub flange socket (male)  															
	Power supply					Incremental signals						Absolute position values			
	1	9	2	11	13	3	4	6	7	10	12	5	8	14	15
$\sim 1 V_{PP}$	U_P	Sensor U_P	0V	Sensor 0V	/	A+	A-	B+	B-	R+	R-	/	/	/	/
$\sim 11 \mu A_{PP}$					Internal shield	I ₁₊	I ₁₋	I ₂₊	I ₂₋	I ₀₊	I ₀₋	/	/	/	/
EnDat						A+	A-	B+	B-	/	/	DATA	DATA	CLOCK	CLOCK

Shield on housing; U_P = power supply voltage

Sensor: The sensor line is connected in the encoder with the corresponding power line.

Vacant pins or wires must not be used!

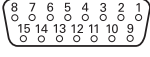
Pin layout of ND 1200R series $\sim 1V_{PP}$



15-pin D-sub flange socket (female)  											
	Power supply				Incremental signals						Others
	4	12	2	10	1	9	3	11	14	7	5/6/8/13/15
$\sim 1V_{PP}$	U_P	Sensor U_P	0V	Sensor 0V	A+	A-	B+	B-	R+	R-	/

Cable shield connected to housing; **U_P** = power supply voltage

Sensor: The sensor line is connected in the encoder with the corresponding power line.

Vacant pins or wires must not be used!

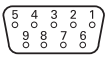
Pin layout of the ND 1200R series \square TTL

9-pin D-sub flange socket (female)  									
	Power supply		Incremental signals						Others
	7	6	2	3	4	5	9	8	1
\square TTL	U_P	0V	U_{a1}	\overline{U}_{a1}	U_{a2}	\overline{U}_{a2}	U_{a0}	\overline{U}_{a0}	/

Cable shield connected to housing; **U_P** = power supply voltage

Vacant pins or wires must not be used!

Interfaces

– Serial data transfer

The digital readouts from HEIDENHAIN feature serial data interfaces for connecting a printer or PC. Depending on the readout's features, it can output measured values, measurement series, parameters and programs. It can also load compensation value tables, parameters and programs, and it can be operated remotely through the simulation of keyed-in commands.

There are many possible ways to **start the measured value transfer**:

- From the keyboard with the EXPORT soft key
- By the software command CTRL B
- Via external signal through a pulse or make contact at a D-sub connection (on POSITIP at IOB 89)
- Through deflection of the edge finder (only on ND 780)

USB

The ND 28x and ND 52x digital readouts have a USB interface function with connector type B. The USB interface functions as a UART (Universal Asynchronous Receiver Transmitter). A special driver software is required for operation (free download at www.heidenhain.de). The data are transferred in ASCII code.

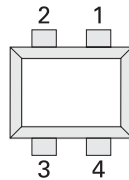

Pin	Assignment
1	V _{CC} + 5 V
2	D- Data -
3	D+ Data +
4	GND Weight

RS-232-C/V.24

This serial interface follows the EIA standard RS-232-C and the CCITT standard V.24.

It uses a 9-pin D-sub female connection.

The data are transferred in ASCII code. The **data format** is adjustable (default value in bold type):

- Start bit
- **7/8** data bits
- Parity bit (**none**/even/odd)
- **1/2** stop bits

Accessories

Connecting cable, complete with two

D-sub connectors (female) 9-pin

ID 366964-xx

Connecting cable, complete with D-sub

connector (female) 9-pin and 25-pin (male)

ID 368017-xx

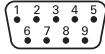

Pin	Assignment
1	Do not assign
3	TXD – Transmitted data
2	RXD – Received data
7	RTS – Request to send
8	CTS – Clear to send
6	DSR – Data set ready
5	SIGNAL GND – Signal ground
4	DTR – Data Terminal Ready
9	Do not assign

Signal	Signal level 1 = active	Signal level 0 = not active
TXD, RXD	-3 V to -15 V	+3 V to +15 V
RTS, CTS DSR, DTR	+3 V to +15 V	-3 V to -15 V

Interfaces

– Switching I/O on ND 780 over IOB 49

The ND 780 provides application-dependent additional functions that are available when the IOB 49 external input/output unit is connected.

IOB 49 external input/output unit

ID 532900-01

The IOB 49 input/output unit is attached to a standard NS 35 rail (DIN 46 227 or EN 50 022). It is connected to the ND 780 using the touch probe input. LEDs show the power supply, the data transmission and the status of the inputs and outputs.

Accessory:

Connecting cable complete with connector, between IOB 49 and ND 780
ID 532899-xx

Distribution cable complete with connectors, for parallel connection of IOB 49 and KT 130 on ND 780
ID 532909-01

The additional functions can be configured on the ND 780 when the IOB 49 is connected.

	IOB 49
4 switching inputs	Zero reset of axes 1 to 3 (for milling applications) Recognition of max. 3 operating gears (for turning applications) External activation of CSS (for turning applications)
9 switching outputs	8 relay outputs as switching functions (for milling applications) 1 relay output for readiness
1 analog output	0 V to 10 V (turning mode) for constant surface speed
Power supply	Through ND 780
Cable length	≤ 15 m to the ND 780
Storage temperature Operating temperature	–20 °C to +70 °C 0 to 45 °C

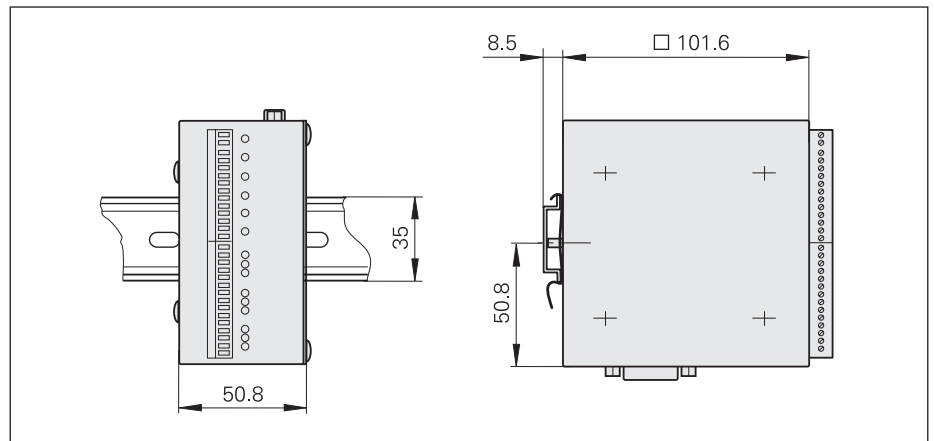

Switching inputs

The switching inputs are active when a High signal (contact or pulse) is present. They are isolated and can be supplied externally or internally.

Signal level of the switching outputs

$$0\text{ V} \leq U_L \leq 1.5\text{ V}$$

$$4.5\text{ V} \leq U_H \leq 26\text{ V}$$

$$I_L \leq 25\text{ mA}$$

$$t_{\min} \geq 100\text{ ms}$$

Zero reset

In the milling mode, each axis can be set to the display value 0 over an external signal.

Detection of gear ranges

In the turning mode, three switching inputs are available for the recognition of gear ranges.

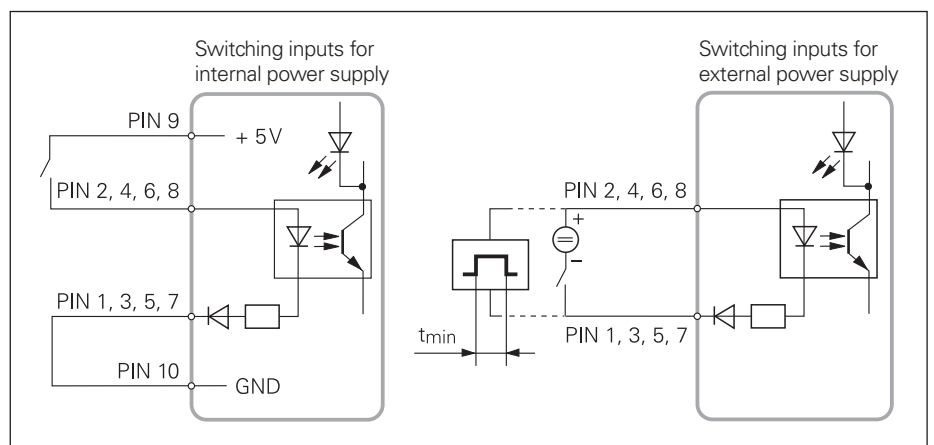

Switching outputs

The IOB 49 features nine floating relay outputs.

Standby

The readiness output is at LOW level when the ND 780 cannot operate the IOB (e.g. not switched on, cable disconnected).

Switching functions (milling mode)

One or more switching ranges or switching points can be defined for an axis. **Switch-off ranges** lie symmetrically to the 0 display value. If **switching points** are used, the relay activates when the position display reaches a specific value. The **direction** function switches when the algebraic sign is changed.

You can set whether

- the switching function should apply to the actual value or distance-to-go mode,
- the relay will open or close when the condition is met,
- or the relay remains activated as long as the switching condition is met (continuous mode) or for a specified duration (pulsed mode).

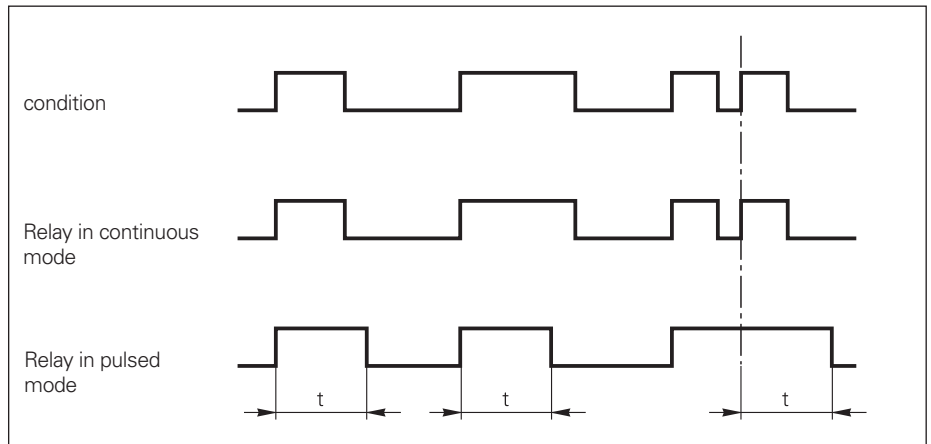
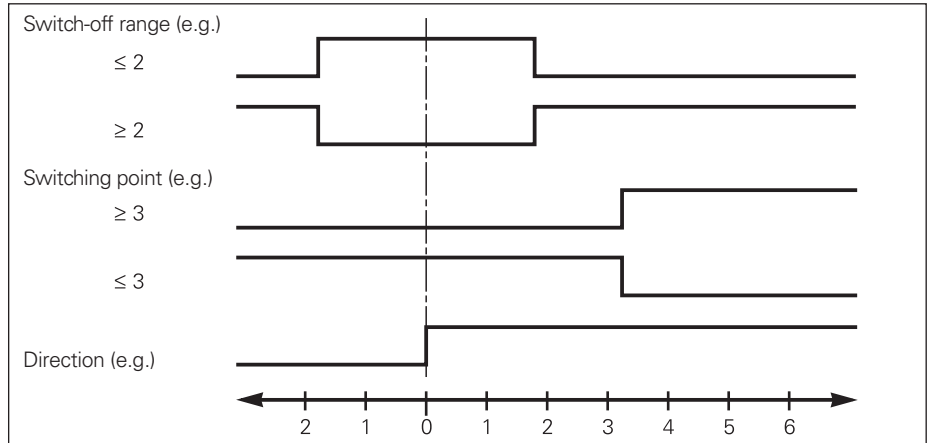
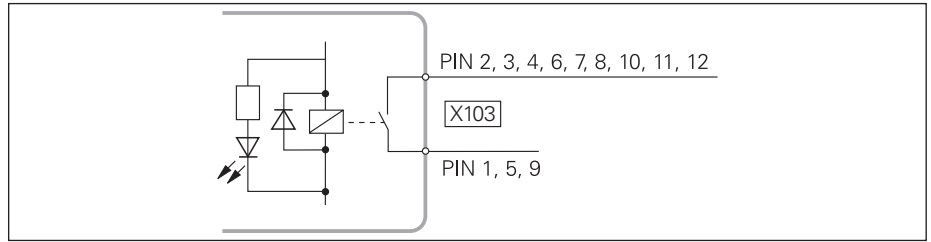

Analog output

Constant surface cutting speed CSS

(in turning mode)

CSS provides spindle speed control as the diameter of the workpiece changes. A speed command signal is sent to the inverter of the spindle motor via the analog interface (0V to 10V DAC) of the IOB 49. The maximum and minimum permissible spindle speeds can be specified. In addition, a maximum of three operating gears can be taken into account. The ND 780 recognizes the current gear selection by means of the switching inputs of the IOB 49. CSS control can also be started remotely (via an input to the CSS board) with an external switch.

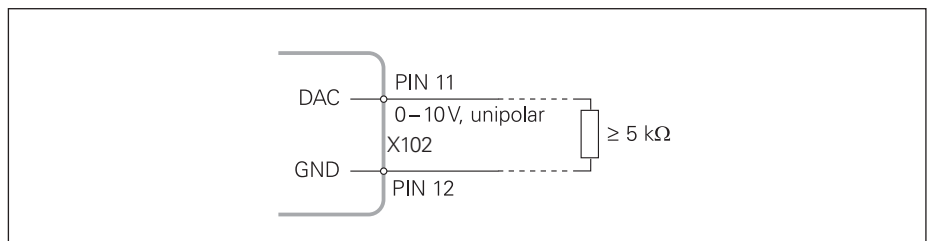

Interfaces

– Switching I/O on POSITIP 880 over IOB 89

The POSITIP 880 features switching functions that you can define as desired. The IOB 89 external input/output unit is necessary to output the switching signals.

IOB 89 external input/output unit ID 532884-01

The IOB 89 input/output unit is attached to a standard NS 35 rail (EN 50 022 or DIN 46 227). It is connected to the POSITIP 880 via the auxiliary machining interface (AMI). LEDs show the status of the inputs and outputs.

Accessory:

Connecting cable complete with connector, between IOB 89 and POSITIP 880
ID 532856-xx

	IOB 89
8 switching inputs	<ul style="list-style-type: none"> • Zero axes 1 to 6 • Start data output (contact or pulse)
9 switching outputs	8 freely definable switching functions 1 switching output ready for POSITIP 880
Power supply	<i>Device:</i> 24 V DC \pm 20 %/max. 1 A <i>Inputs:</i> 5 V DC or 24 V DC \pm 20 %/min. 0.25 A
Cable length	Max. 10 m to POSITIP 880
Storage temperature Operating temperature	-20 °C to +70 °C 0 to 45 °C

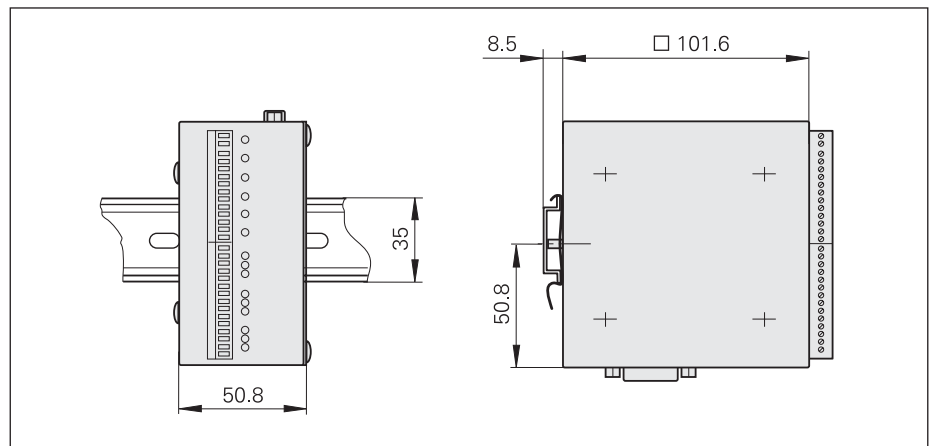

Switching inputs

All switching inputs respond either to contact or pulse. **Exception:** The switching inputs for transmitting measured values over the data interface are separate for contact and pulse.

The switching input E is active when a Low signal U_L is applied (contact or pulse to 0V).

Signal level

- $0.5V \leq U_L \leq 0.9V$ with $I_L \leq 6\text{ mA}$
- $3.9V \leq U_H \leq 15.0V$
- $t_{min} \geq 30\text{ ms}$

Zero reset

Each axis can be set to the display value 0 over an external signal.

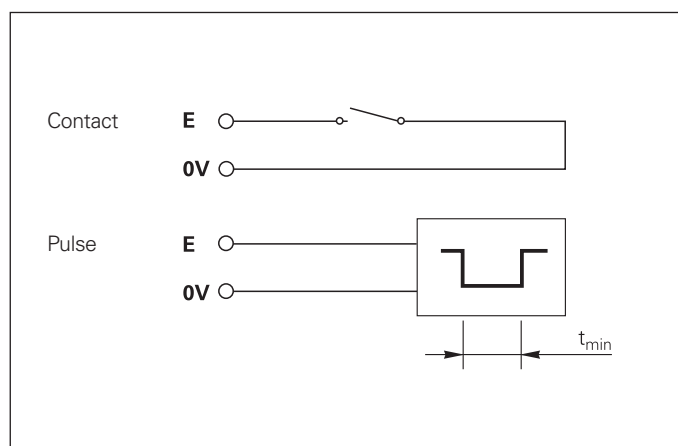

Switching outputs

Signal level of the switching outputs

$U_L \leq 1.5\text{ V}$ with $I_L \leq 100\text{ mA}$
 $U_H \leq 24\text{ V}$ with $I_H \leq 0.3\text{ mA}$

Delay until signal output

$t_V \leq 10\text{ ms}$

Standby

This permanently available output is at LOW level when the POSITIP 880 cannot operate the IOB (e.g., not switched on, cable interrupted).

Switching I/O functions

The switching outputs can be configured on the POSITIP 880 when the IOB 89 is connected, and assigned to any axes. The following functions are possible:

Output of the traverse direction

The output switches with each change of the direction of traverse.

Switch-off ranges

The switch-off ranges are located symmetrically around the display value 0. They can be assigned to the axes in any manner. In the distance-to-go display mode (traverse to 0), switch-off signals are generated for any target position.

Trigger points

The output switches at the programmed position. The algebraic sign is taken into account.

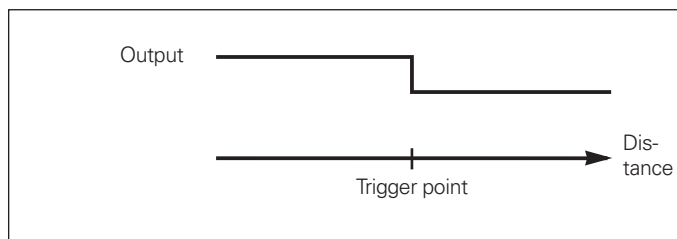
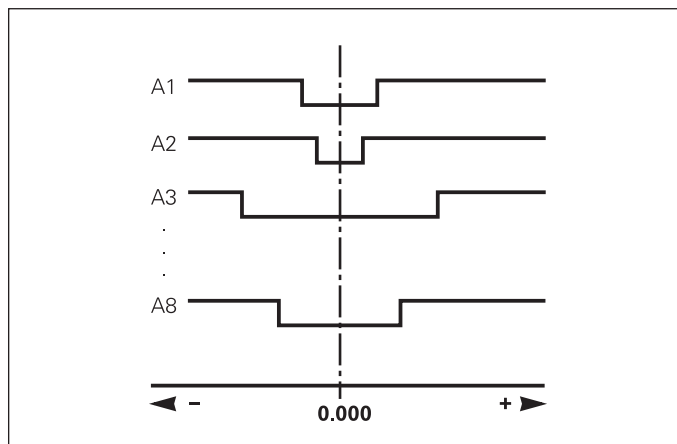
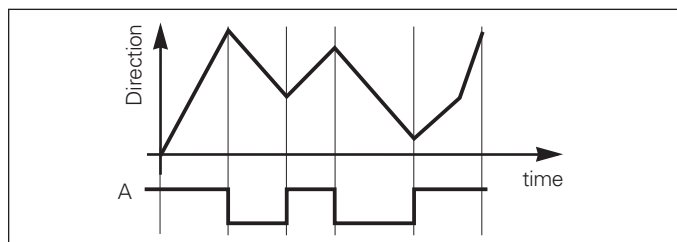
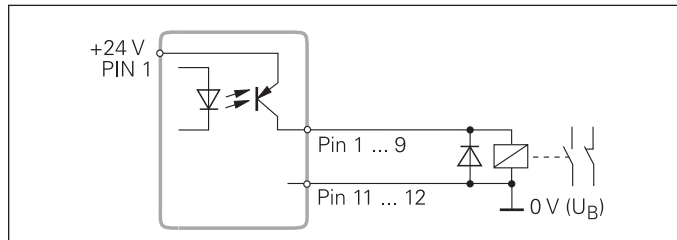

Accessories

– External operating elements for ND 1200 R

With the foot switch, you can remotely operate the ND 1200 R, e.g. to switch to the next drilling position.

Foot switch (accessory)

With two freely assignable keys

Cable length 2.4 m

For ND with RJ 45 connector

ID 681041-01



Foot switch

Cable overview

– ND 28x, ND 52x

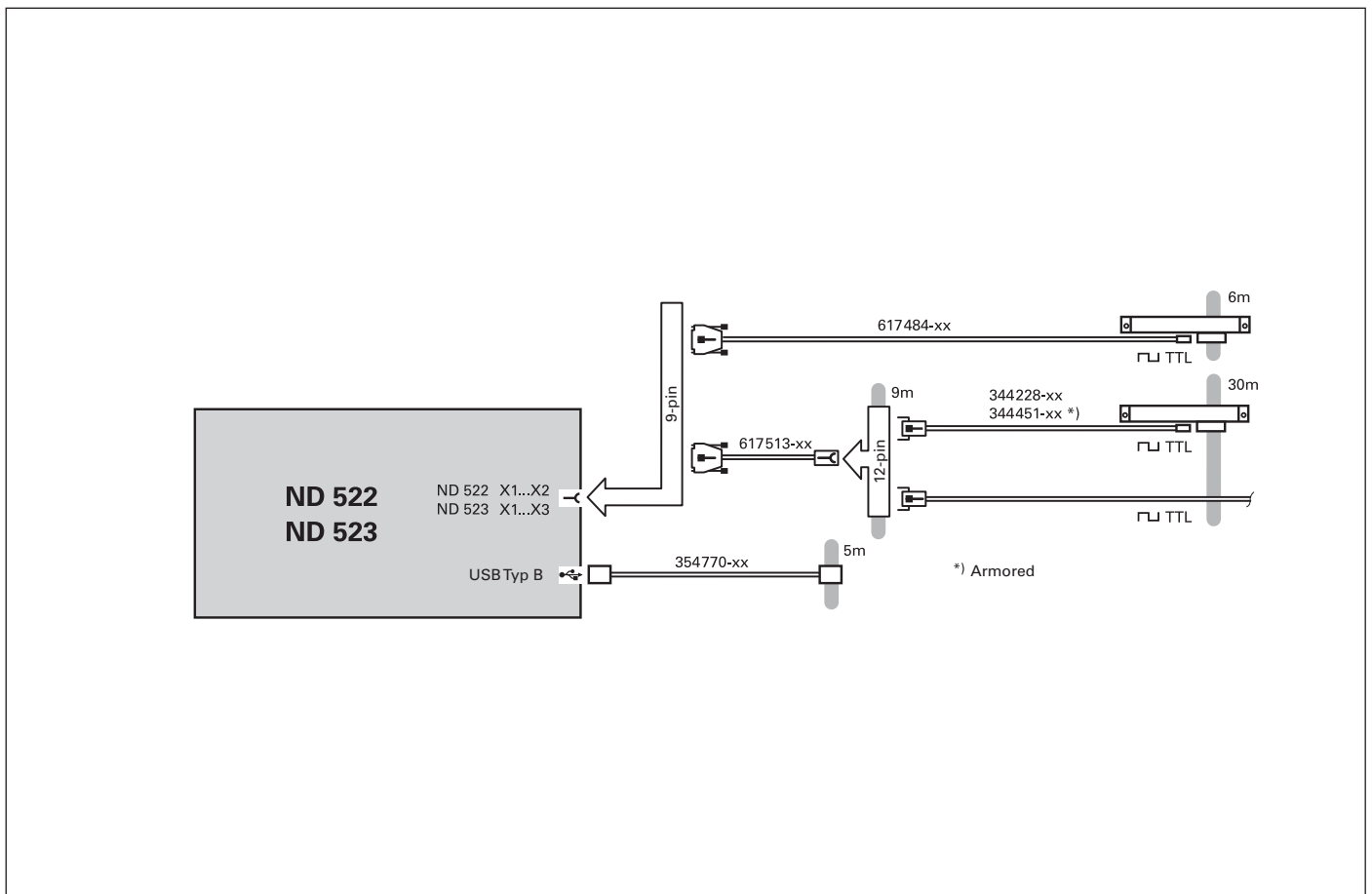
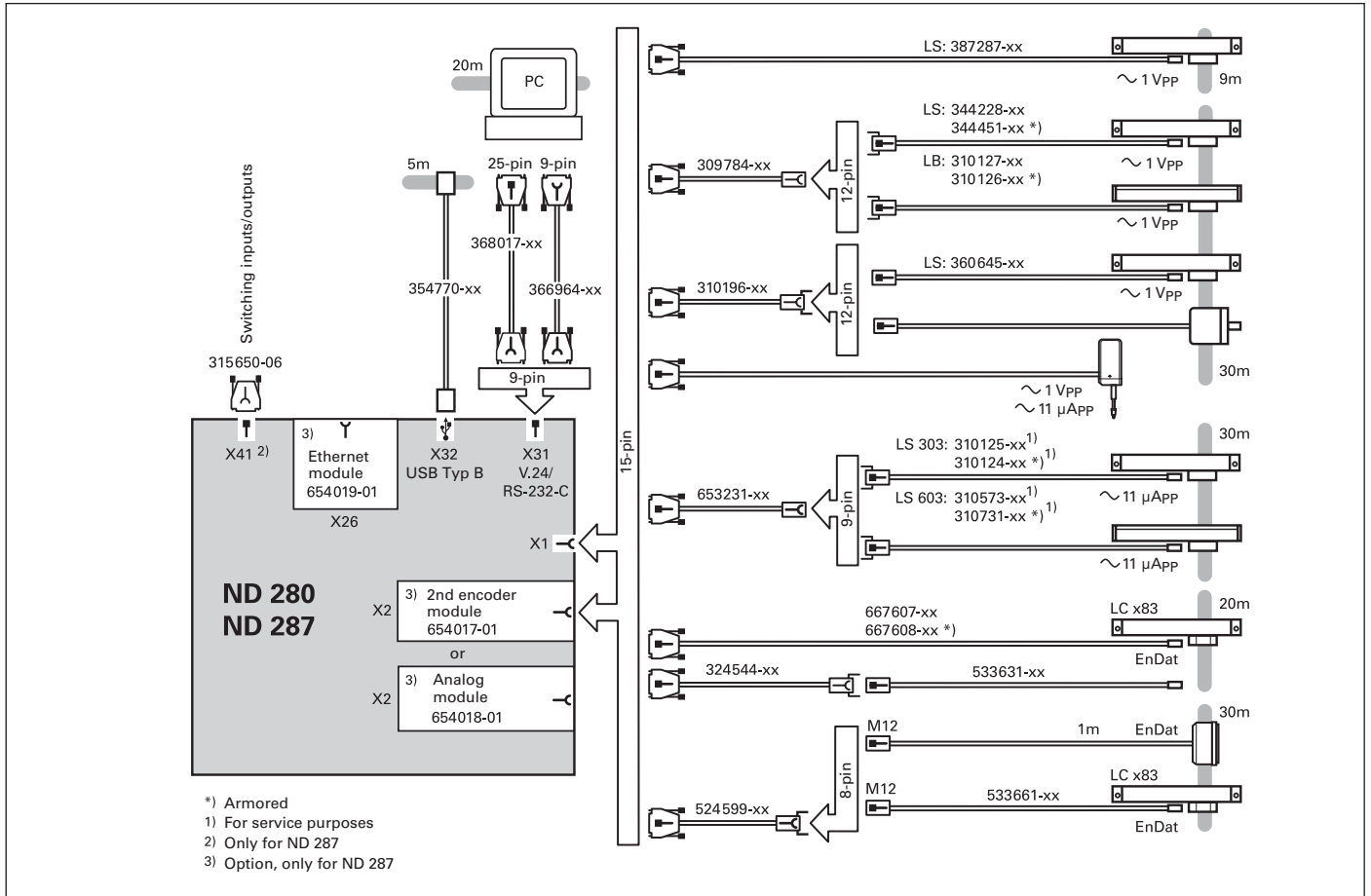

Cable overview

– ND 780, POSITIP

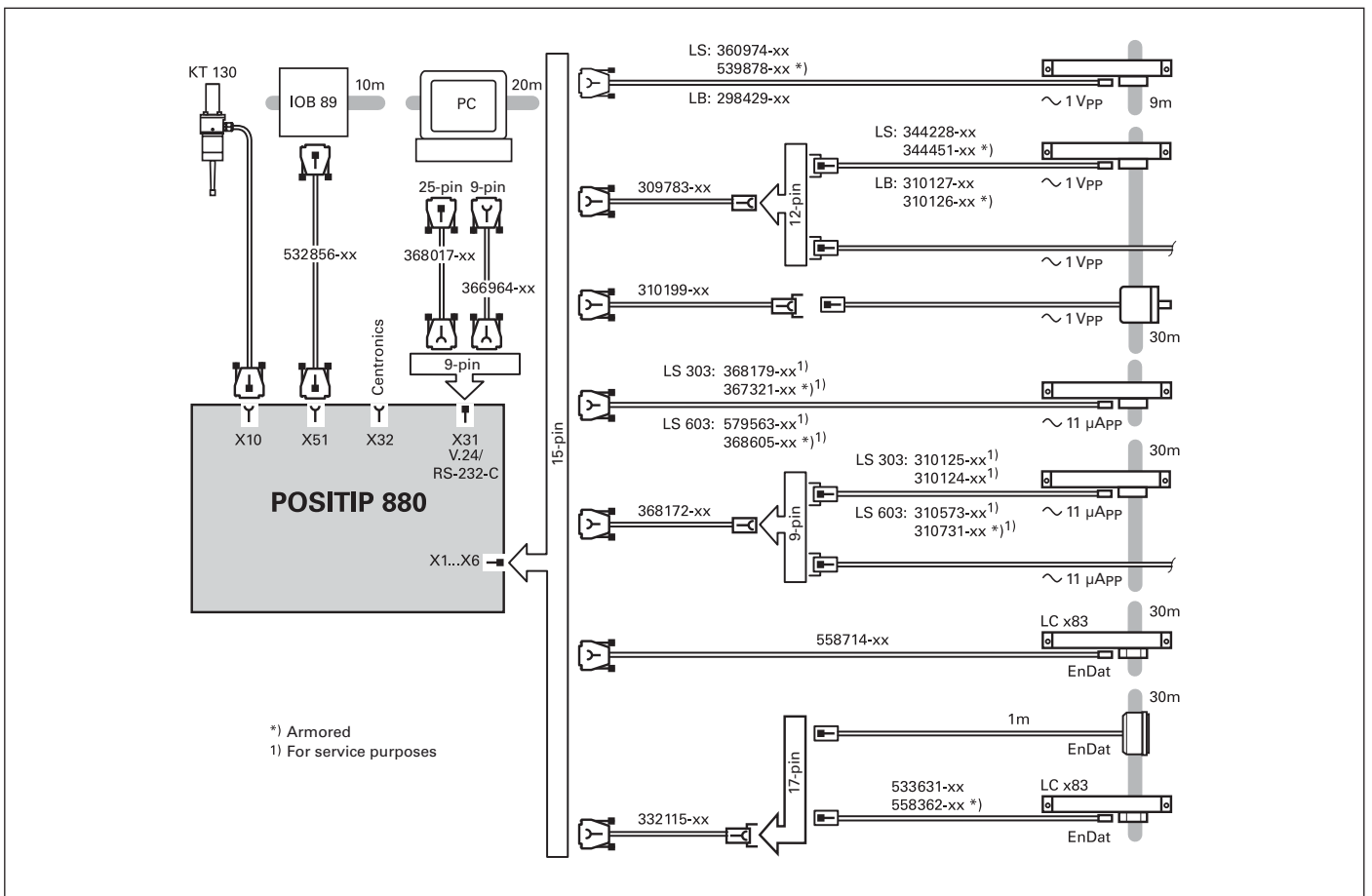
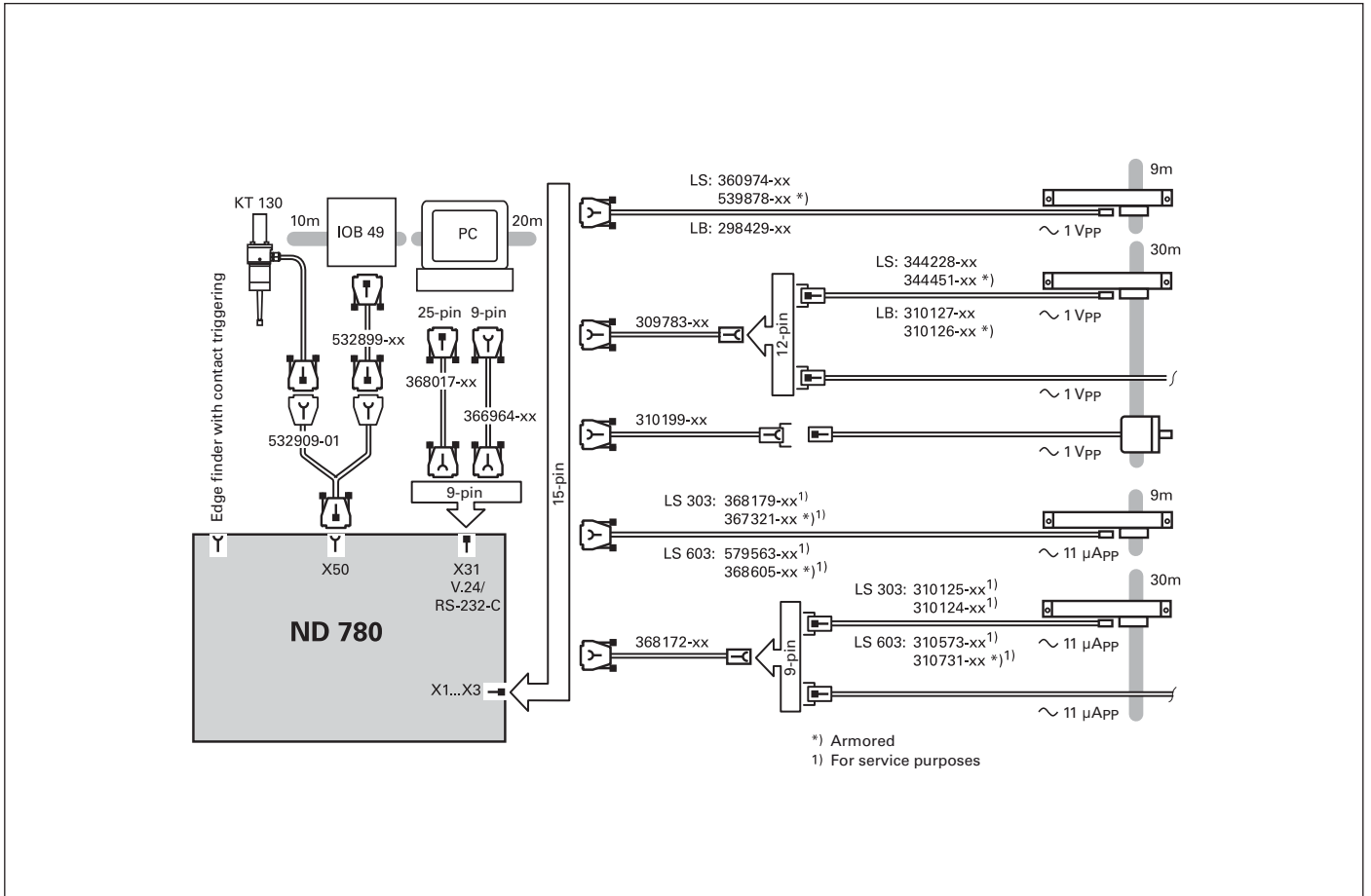

- ND 120xR

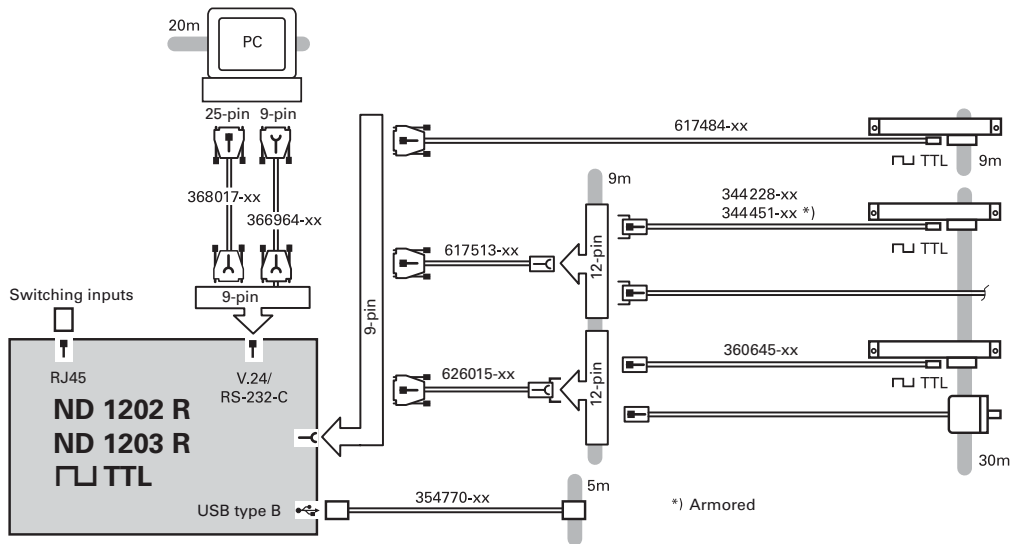
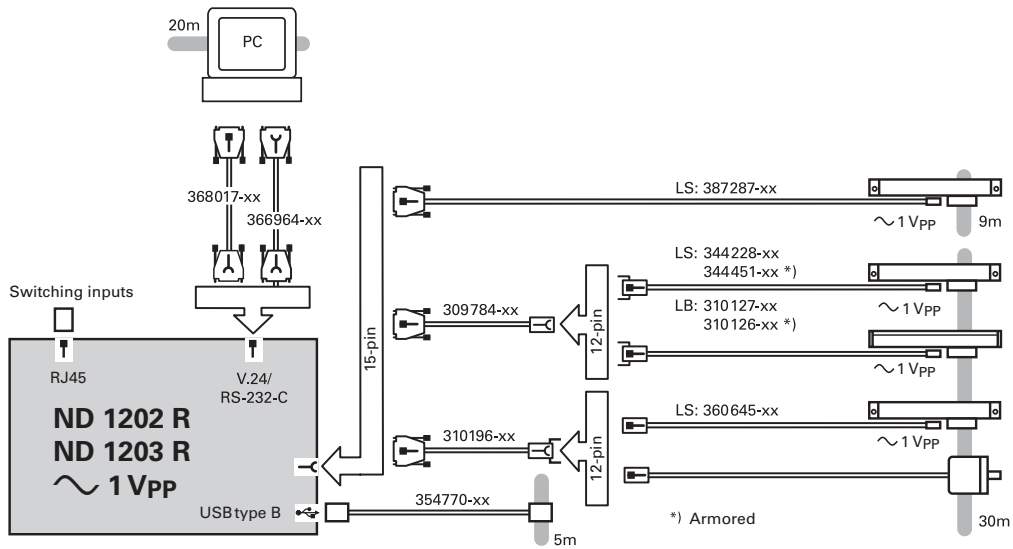

Linear encoders

– For manually operated machine tools

For typical applications on manual machine tools such as milling machines or lathes, **display steps of 10 µm or 5 µm** are sufficient. Such display steps are provided by the LS 300 and LS 600 series linear encoders with an accuracy grade of $\pm 10 \mu\text{m}$ per meter traverse.

Jig boring machines, grinding machines, and measuring and inspection tasks normally require **display steps of 1 µm** and better. Linear encoders for these more stringent requirements typically feature accuracy grades of $\pm 5 \mu\text{m}$ per meter traverse.

These linear encoders, such as LS 487 or LS 187, are described in the *Linear Encoders for Numerically Controlled Machine Tools* brochure.

For **limited installation space**, for example on the slide of a lathe, linear encoders may be the best solution.

The linear encoders with full-sized scale housing function as universal linear encoders under **normal mounting conditions**.

Linear encoders for large traverses

On large boring or milling machines, but also on lathes with long Z axes, traverse ranges can extend to three meters and more. HEIDENHAIN has the proper linear encoders for such special applications.

The **LB 382** or **LC 200** with full-sized scale housing permit **measuring lengths up to 30040 mm** or **28040 mm**, respectively. The housing is assembled from sections and mounted on the machine, and the single steel scale tape is then pulled into its slot. The LB 382 and LC 200 are described in the catalog titled *Linear Encoders for Numerically Controlled Machine Tools*.

Absolute linear encoders

Encoders for absolute position measurement are used on machines and equipment where axis positions must already be known upon switch-on. The LC 415, LC 115 and LC 200 absolute linear encoders are described in the *Linear Encoders for Numerically Controlled Machine Tools* brochure. A product information sheet is available for the LC 183 and LC 483.

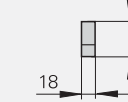
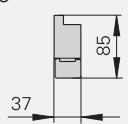
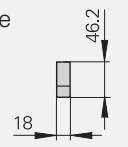
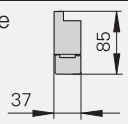
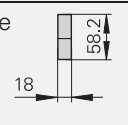
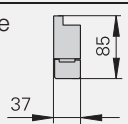
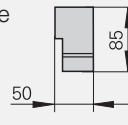
	Scale housing	Accuracy grade	Measuring lengths
Recommended measuring steps 10 µm, 5 µm			
Incremental linear measurement • Glass scale	Slimline LS 388: 46.2 LS 328: 58.1 	$\pm 10 \mu\text{m}$	70 mm to 1240 mm
	Full size 	$\pm 10 \mu\text{m}$	140 mm to 3040 mm
Recommended measuring steps 1 µm, 0.5 µm and finer			
Incremental linear measurement • Glass scale	Slimline 	$\pm 5 \mu\text{m}$ $\pm 3 \mu\text{m}$	70 to 1240 mm <i>With mounting spar:</i> 70 mm to 2040 mm
	Full size 	$\pm 5 \mu\text{m}$ $\pm 3 \mu\text{m}$	140 mm to 3040 mm
Absolute linear measurement • Glass scale	Slimline 	$\pm 5 \mu\text{m}$ $\pm 3 \mu\text{m}$	70 to 1240 mm <i>With mounting spar or clamping elements:</i> 70 mm to 2040 mm
	Full size 	$\pm 5 \mu\text{m}$ $\pm 3 \mu\text{m}$	140 mm to 3040 mm
Recommended measuring steps 10 µm, 5 µm, 1 µm			
Incremental linear measurement for large measuring lengths • Steel scale tape	Full size 	$\pm 5 \mu\text{m}$	440 mm to 30040 mm
Absolute linear measurement for large measuring lengths • Steel scale tape			4240 mm to 28040 mm



LB 382

	Interface	Signal period	Type	For more information
	~ 1 V _{PP}	20 μm	LS 388C	Page 48
	□TTL	20 μm	LS 328C	
	~ 1 V _{PP}	20 μm	LS 688C	Page 50
	□TTL	20 μm	LS 628C	
	~ 1 V _{PP}	20 μm	LS 487	Catalog <i>Linear encoders for numerically controlled machine tools</i>
	□TTL	To 1 μm	LS 477	
	~ 1 V _{PP}	20 μm	LS 187	* Product Information <i>LC 183</i> <i>LC 483</i>
	□TTL	To 1 μm	LS 177	
	EnDat 2.2	–	LC 415	
	EnDat 2.2 with ~ 1 V _{PP}	20 μm	LC 483*	
	EnDat 2.2	–	LC 115	
	EnDat 2.2 with ~ 1 V _{PP}	20 μm	LC 183*	
	~ 1 V _{PP}	40 μm	LB 382	Catalog <i>Linear encoders for numerically controlled machine tools</i>
	EnDat 2.2 with ~ 1 V _{PP}	40 μm	LC 281	
	EnDat 2.2	–	LC 211	



LS 388C



LS 688C



LS 487/LC 415



LS 187/LC 115



LC 281/LC 211



LS 300 series

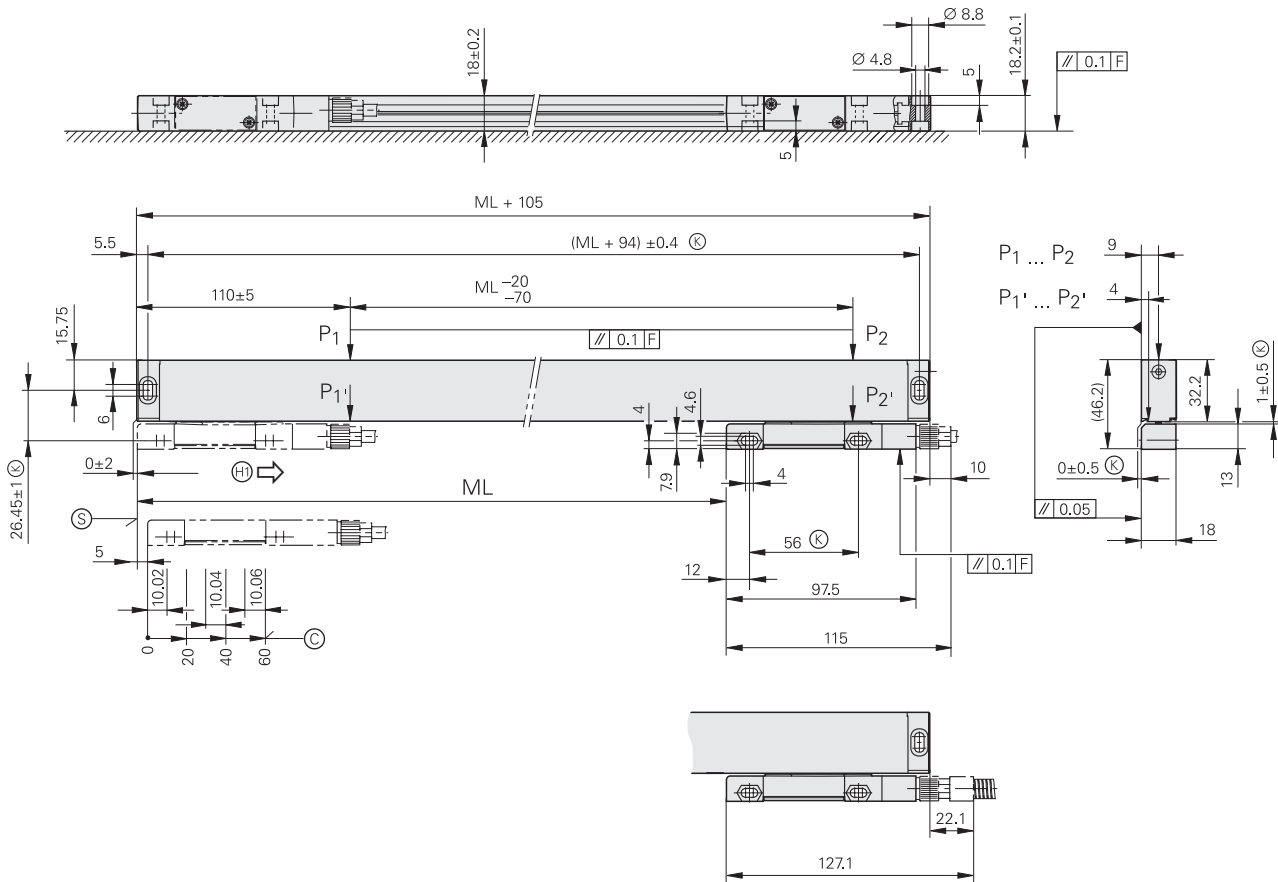

mm



Tolerancing ISO 8015
ISO 2768 - m H
< 6 mm: ± 0.2 mm

Ⓢ = Beginning of measuring length (ML)

Ⓞ = Reference mark position

F = Machine guideway

P = Gauging points for alignment

Ⓚ = Required mating dimensions

Ⓢ = Direction of scanning unit for output signals in accordance with interface description



Specifications	Incremental	
	LS 388C	LS 328C
Measuring standard	Glass scale with DIADUR graduation	
Accuracy grade	± 10 µm	
Measuring length ML*	70 120 170 220 270 320 370 420 470 520 570 620 670 720 770 820 870 920 970 1020 1140 1240	
Interface	~ 1 V _{PP}	□TTL
Grating period	20 µm	
Edge separation a	–	≤ 5 µs
Reference mark	Distance-coded	
Recommended measuring step¹⁾	10 µm, 5 µm	
Power supply	5 V DC ± 0.25V/< 100 mA (without load)	
Electrical connection	Separate adapter cable connectable to mounting block	
Cable length	≤ 30 m (with HEIDENHAIN cable)	
Traversing speed	≤ 60 m/min	
Required moving force	≤ 5 N	
Vibration 55 to 2000 Hz Shock 6 ms	≤ 150 m/s ² (EN 60068-2-6) ≤ 300 m/s ² (EN 60068-2-27)	
Operating temperature	0 °C to +50 °C	
Protection EN 60 529	IP 53 when mounted according to the instructions	
Weight	0.27 kg + 0.67 kg/m measuring length	

* Please select when ordering

¹⁾ For position measurement

Please refer—especially for connection to non-HEIDENHAIN electronics—to the *General electrical information* in the *Interfaces of HEIDENHAIN Encoders* catalog.

LS 600 series

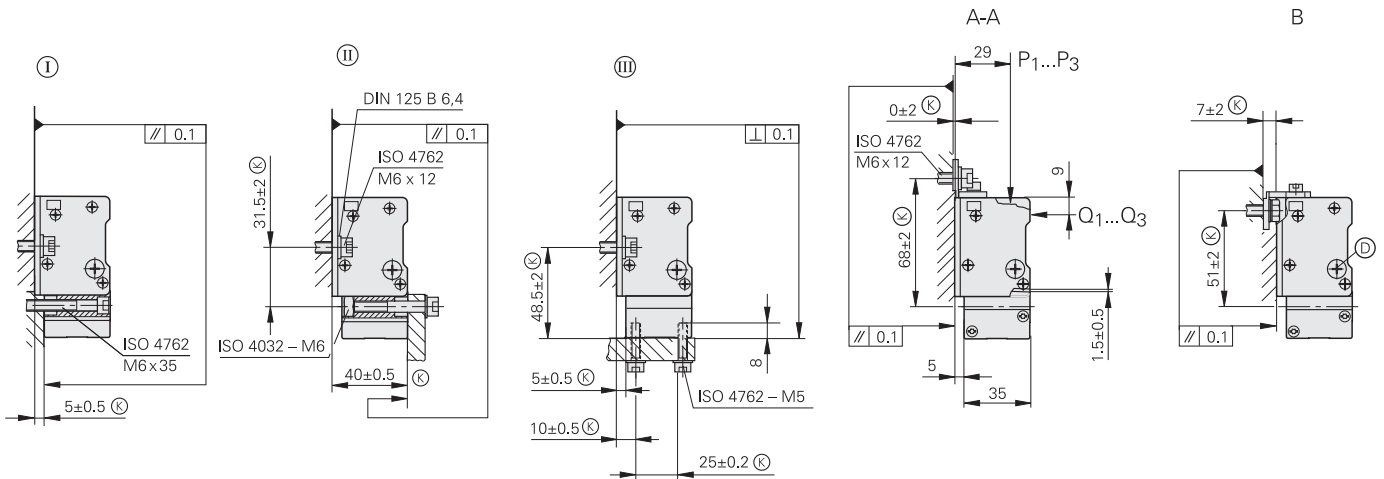
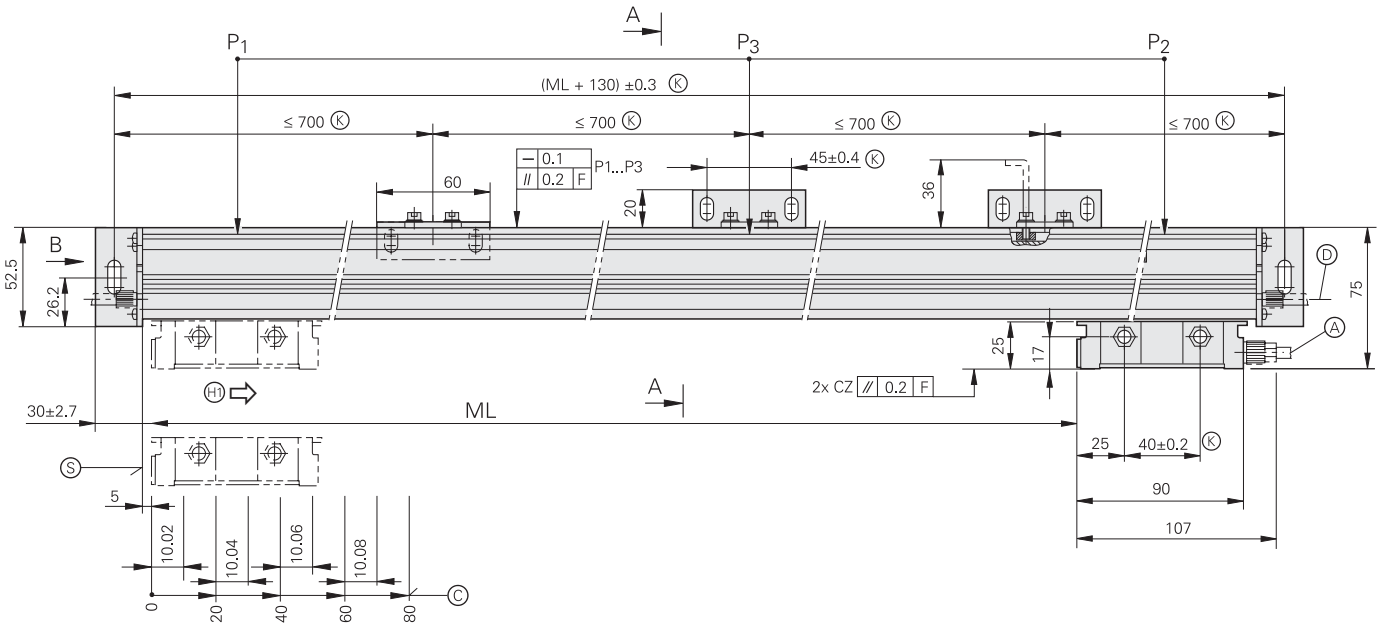
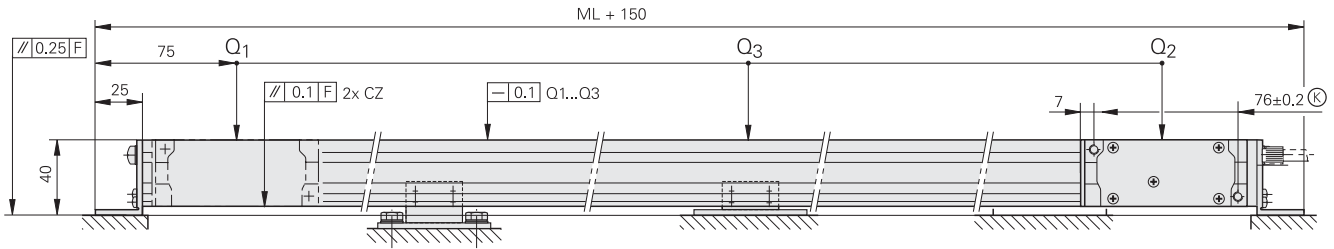

mm

 Tolerancing ISO 8015
 ISO 2768 - m H
 < 6 mm: ±0.2 mm

- Ⓘ, Ⓚ, Ⓛ = Mounting options
- F = Machine guideway
- P, Q = Gauging points for alignment
- Ⓐ = Cable connection usable at either end
- Ⓚ = Compressed air inlet usable at either end
- Ⓛ = Required mating dimensions
- Ⓜ = Beginning of measuring length (ML)
- Ⓝ = Reference-mark position on LS 6x8 C
- Ⓢ = Direction of scanning unit for output signals in accordance with interface description



Specifications	Incremental	
	LS 688C	LS 628C
Measuring standard	Glass scale with DIADUR graduation	
Accuracy grade	± 10 µm	
Measuring length ML*	170 220 270 320 370 420 470 520 570 620 670 720 770 820 870 920 970 1020 1140 1240 1340 1440 1540 1640 1740 1840 2040 2240 2440 2640 2840 3040	
Interface	~ 1 V _{PP}	□ TTL
Grating period	20 µm	
Edge separation a	–	≤ 5 µs
Reference mark	Distance-coded	
Recommended measuring step¹⁾	10 µm, 5 µm	
Power supply	5 V DC ± 0.25V/< 100 mA (without load)	
Electrical connection	Separate adapter cable connectable to mounting block	
Cable length	≤ 30 m (with HEIDENHAIN cable)	
Traversing speed	≤ 60 m/min	
Required moving force	≤ 5 N	
Vibration 55 to 2000 Hz Shock 6 ms	≤ 150 m/s ² (EN 60068-2-6) ≤ 300 m/s ² (EN 60068-2-27)	
Operating temperature	0 °C to 50 °C	
Protection EN 60 529	IP 53 when mounted according to the instructions	
Weight	0.7 kg + 2 kg/m ML	

* Please select when ordering

¹⁾ For position measurement

Please refer—especially for connection to non-HEIDENHAIN electronics—to the *General electrical information* in the *Interfaces of HEIDENHAIN Encoders* catalog.

Mounting instructions

LS 300 series

The slimline linear encoders should be fastened over their entire length onto a machined surface. The encoder is mounted so that the sealing lips are directed downward or away from splashwater.

Assembly

It is surprisingly simple to mount the LS 300 sealed linear encoders: you need only align the scale unit at several points along the machine guideway. Stop surfaces or stop pins can also be used to align the scale.

Use the mounting gauge to easily and quickly set the gap between the scale housing and the scanning unit. Ensure that the lateral tolerances are also maintained.

Accessories

Mounting gauge

ID 528753-01

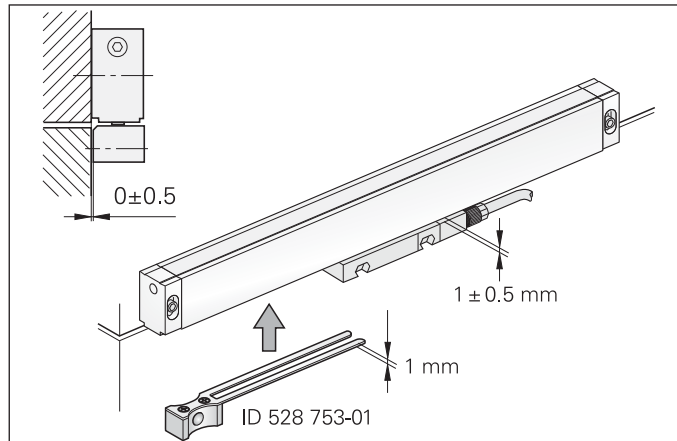
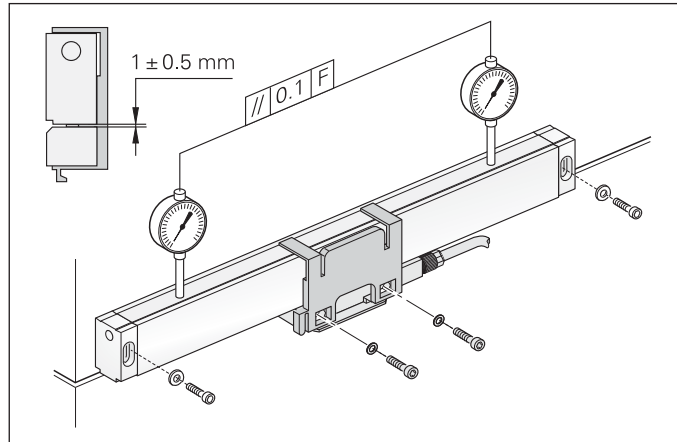

LS 600 series

The full-size linear encoders are fastened to a machined surface only at the ends with their mounting blocks. Measuring lengths over 620 mm require one or more support brackets to improve vibration behavior.

The inclined arrangement of the sealing lips permits universal mounting with vertical or horizontal scale housing with equally high protection rating.

Assembly

When mounting the LS 600, the shipping brace already sets the proper gap between the scale unit and the scanning unit. You need only align the scale unit at several points along the machine guideway.

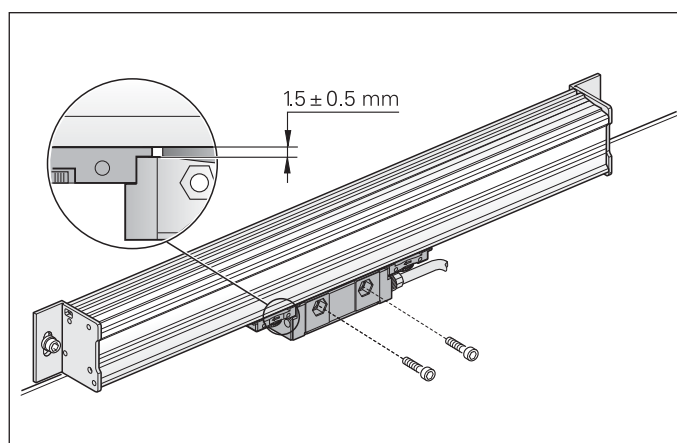
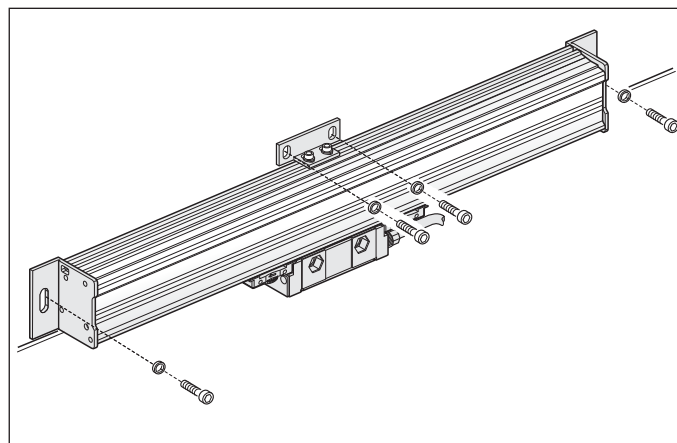

Interfaces

Incremental signals $\sim 1 V_{PP}$

HEIDENHAIN encoders with $\sim 1 V_{PP}$ interface provide voltage signals that can be highly interpolated.

The sinusoidal **incremental signals** A and B are phase-shifted by 90° elec. and have amplitudes of typically $1 V_{PP}$. The illustrated sequence of output signals—with B lagging A—applies for the direction of motion shown in the dimension drawing.

The **reference mark signal** R has an unambiguous assignment to the incremental signals. The output signal might be somewhat lower next to the reference mark.

Comprehensive descriptions of all available interfaces as well as general electrical information are included in the *Interfaces for HEIDENHAIN Encoders* catalog.

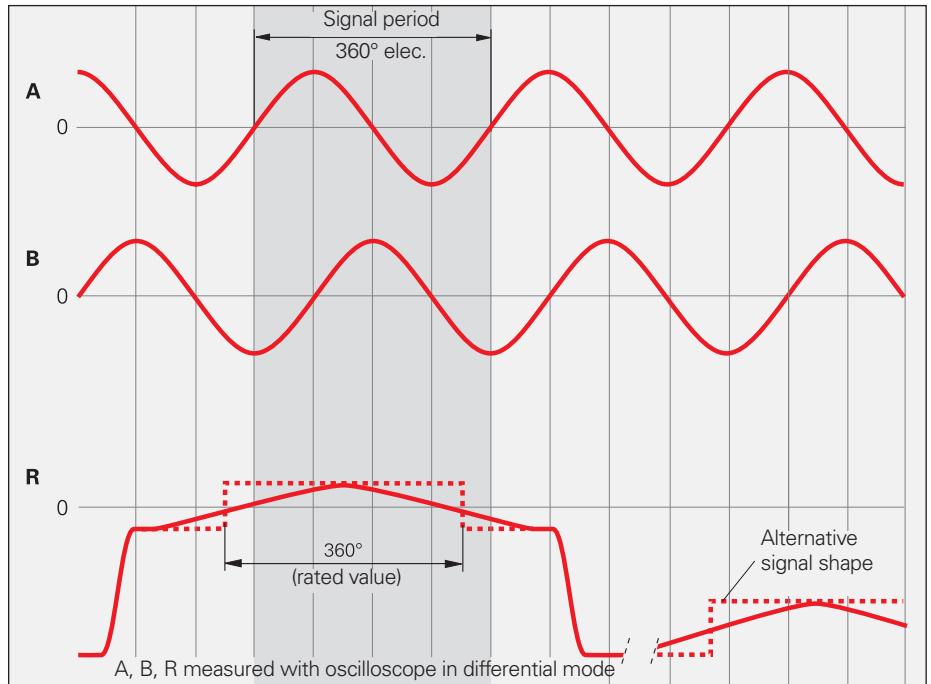

Pin layout for LS 388 C, LS 688 C

12-pin M23 coupling (male) 					12-pin M23 connector (male) 								
15-pin D-sub connector (female) For ND 780, POSITIP, IK 220 					15-pin D-sub connector (male) For ND 28x 								
	Power supply				Incremental signals						Other signals		
	12	2	10	11	5	6	8	1	3	4	9	7	/
	1	9	2	11	3	4	6	7	10	12	5/8/13/15	14	-
	4	12	2	10	1	9	3	11	14	7	5/6/8/15	13	/
	U_P	Sensor¹⁾ U _P	0V	Sensor¹⁾ 0V	A+	A-	B+	B-	R+	R-	Vacant	Vacant	Vacant
	Brown/ Green	Blue	White/ Green	White	Brown	Green	Gray	Pink	Red	Black	/	Violet	Yellow

Shield on housing; **U_P** = power supply

Sensor: The sensor line is connected internally with the corresponding power line.

Vacant pins or wires must not be used!

¹⁾ **LIDA 2xx:** Vacant

Incremental signals

HEIDENHAIN encoders with TTL interface incorporate electronics that digitize sinusoidal scanning signals with or without interpolation.

The **incremental signals** are transmitted as the square-wave pulse trains U_{a1} and U_{a2} , phase-shifted by 90° elec. The **reference mark signal** consists of one or more reference pulses U_{a0} , which are gated with the incremental signals. In addition, the integrated electronics produce their **inverted signals** $\overline{U_{a1}}$, $\overline{U_{a2}}$ and $\overline{U_{a0}}$ for noise-proof transmission. The illustrated sequence of output signals—with U_{a2} lagging U_{a1} —applies to the direction of motion shown in the dimension drawing.

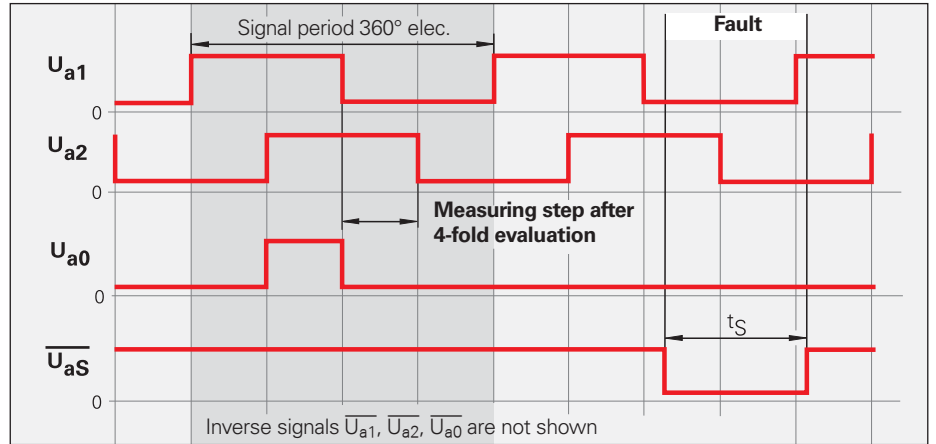





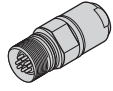
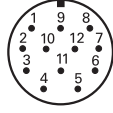
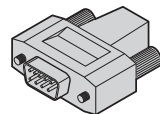
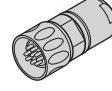
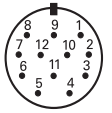

The **fault detection signal** $\overline{U_{aS}}$ indicates fault conditions such as an interruption in the supply lines, failure of the light source, etc.

The distance between two successive edges of the incremental signals U_{a1} and U_{a2} through 1-fold, 2-fold or 4-fold evaluation is one **measuring step**.

Comprehensive descriptions of all available interfaces as well as general electrical information are included in the *Interfaces for HEIDENHAIN Encoders* catalog.

Pin layout for LS 328 C, LS 628 C

12-pin M23 coupling, (male)					12-pin M23 connector, (male)									
														
9-pin D-sub connector, (male) For ND 52x														
														
	Power supply				Incremental signals						Other signals			
	12	2	10	11	5	6	8	1	3	4	7	/	9	
	7	/	6	/	2	3	4	5	9	8	/	1	/	
	U_P	Sensor U_P	0V	Sensor 0V	U_{a1}	$\overline{U_{a1}}$	U_{a2}	$\overline{U_{a2}}$	U_{a0}	$\overline{U_{a0}}$	$\overline{U_{aS}}$	Vacant	Vacant	
	Brown/ Green	Blue	White/ Green	White	Brown	Green	Gray	Pink	Red	Black	Violet	/	Yellow	





Cable shield connected to housing; U_P = power supply voltage

Sensor: The sensor line is connected internally with the corresponding power line.

Vacant pins or wires must not be used!



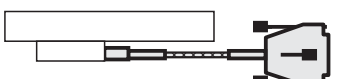



Electrical connection

Cables and connecting elements

PUR adapter cable [6(2 x 0.19 mm ²)]; A _P = 0.19 mm ²		LS 388C LS 688C	LS 328C LS 628C
With M23 connector (male), 12-pin Extension cable Ø 6 mm		344228-xx	
In metal armor with M23 connector (male), 12-pin Extension cable Ø 10 mm		344451-xx	
With D-sub connector, (male), 15-pin Cable for ND 28x Ø 6 mm		387287-xx	–
In protective braiding with D-sub connector, (male), 9-pin Cable for ND 52x Ø 6 mm		–	617484-xx ¹⁾
With D-sub connector, (female) 15-pin Cable for ND 780 and PT 880 Ø 6 mm		360974-xx	–
With armor and D-sub connector, (female) 15-pin Cable for ND 780 and PT 880 Ø 10 mm		539878-xx	–

Available cable lengths: 1 m/3 m/6 m/9 m

¹⁾ Max. cable length 6 m

PUR connecting cable Ø 8 mm 12-pin: [4(2 x 0.14 mm ²) + (4 x 0.5 mm ²)]; A _P = 0.5 mm ²		LS 388C LS 688C	LS 328C LS 628C
Complete For extension with M23 coupling (female) 12-pin and M23 connector (male), 12-pin		298400-xx	
Complete For ND 28x with M23 coupling (female), 12-pin and D-sub connector (male), 15-pin		309784-xx	
With one connector For ND 52x with M23 coupling (female), 12-pin and D-sub connector (male), 9-pin		–	617484-xx
Complete For ND 780, POSITIP 880 with M23 coupling (female), 12-pin and D-sub connector (male), 15-pin		309783-xx	–
With one connector With M23 coupling (female), 12-pin		298402-xx	
Cable only		816317-xx	

A_P: Cross section of power supply lines

HEIDENHAIN

DR. JOHANNES HEIDENHAIN GmbH

Dr.-Johannes-Heidenhain-Straße 5

83301 Traunreut, Germany

☎ +49 8669 31-0

FAX +49 8669 5061

E-mail: info@heidenhain.de

www.heidenhain.de

Vollständige und weitere Adressen siehe www.heidenhain.de
For complete and further addresses see www.heidenhain.de

DE	HEIDENHAIN Vertrieb Deutschland 83301 Traunreut, Deutschland ☎ 08669 31-3132 FAX 08669 32-3132 E-Mail: hd@heidenhain.de	ES	FARRESA ELECTRONICA S.A. 08028 Barcelona, Spain www.farresa.es	PL	APS 02-384 Warszawa, Poland www.heidenhain.pl
	HEIDENHAIN Technisches Büro Nord 12681 Berlin, Deutschland ☎ 030 54705-240	FI	HEIDENHAIN Scandinavia AB 02770 Espoo, Finland www.heidenhain.fi	PT	FARRESA ELECTRÓNICA, LDA. 4470 - 177 Maia, Portugal www.farresa.pt
	HEIDENHAIN Technisches Büro Mitte 07751 Jena, Deutschland ☎ 03641 4728-250	FR	HEIDENHAIN FRANCE sarl 92310 Sèvres, France www.heidenhain.fr	RO	HEIDENHAIN Reprezentantă Romania Braşov, 500407, Romania www.heidenhain.ro
	HEIDENHAIN Technisches Büro West 44379 Dortmund, Deutschland ☎ 0231 618083-0	GB	HEIDENHAIN (G.B.) Limited Burgess Hill RH15 9RD, United Kingdom www.heidenhain.co.uk	RS	Serbia → BG
	HEIDENHAIN Technisches Büro Südwest 70771 Leinfelden-Echterdingen, Deutschland ☎ 0711 993395-0	GR	MB Milionis Vassilis 17341 Athens, Greece www.heidenhain.gr	RU	OOO HEIDENHAIN 115172 Moscow, Russia www.heidenhain.ru
	HEIDENHAIN Technisches Büro Südost 83301 Traunreut, Deutschland ☎ 08669 31-1345	HK	HEIDENHAIN LTD Kowloon, Hong Kong E-mail: sales@heidenhain.com.hk	SE	HEIDENHAIN Scandinavia AB 12739 Skärholmen, Sweden www.heidenhain.se
		HR	Croatia → SL	SG	HEIDENHAIN PACIFIC PTE LTD. Singapore 408593 www.heidenhain.com.sg
AR	NAKASE SRL. B1653AOX Villa Ballester, Argentina www.heidenhain.com.ar	HU	HEIDENHAIN Kereskedelmi Képviselet 1239 Budapest, Hungary www.heidenhain.hu	SK	KOPRETINA TN s.r.o. 91101 Trenčín, Slovakia www.kopretina.sk
AT	HEIDENHAIN Techn. Büro Österreich 83301 Traunreut, Germany www.heidenhain.de	ID	PT Servitama Era Toolsindo Jakarta 13930, Indonesia E-mail: ptset@group.gts.co.id	SL	NAVO d.o.o. 2000 Maribor, Slovenia www.heidenhain.si
AU	FCR Motion Technology Pty. Ltd Laverton North 3026, Australia E-mail: vicsales@fcrmotion.com	IL	NEUMO VARGUS MARKETING LTD. Tel Aviv 61570, Israel E-mail: neumo@neumo-vargus.co.il	TH	HEIDENHAIN (THAILAND) LTD Bangkok 10250, Thailand www.heidenhain.co.th
BE	HEIDENHAIN NV/SA 1760 Roosdaal, Belgium www.heidenhain.be	IN	HEIDENHAIN Optics & Electronics India Private Limited Chetpet, Chennai 600 031, India www.heidenhain.in	TR	T&M Mühendislik San. ve Tic. LTD. ŞTİ. 34728 Ümraniye-Istanbul, Turkey www.heidenhain.com.tr
BG	ESD Bulgaria Ltd. Sofia 1172, Bulgaria www.esd.bg	IT	HEIDENHAIN ITALIANA S.r.l. 20128 Milano, Italy www.heidenhain.it	TW	HEIDENHAIN Co., Ltd. Taichung 40768, Taiwan R.O.C. www.heidenhain.com.tw
BR	DIADUR Indústria e Comércio Ltda. 04763-070 – São Paulo – SP, Brazil www.heidenhain.com.br	JP	HEIDENHAIN K.K. Tokyo 102-0083, Japan www.heidenhain.co.jp	UA	Gertner Service GmbH Büro Kiev 01133 Kiev, Ukraine www.heidenhain.ua
BY	GERTNER Service GmbH 220026 Minsk, Belarus www.heidenhain.by	KR	HEIDENHAIN Korea LTD. Gasan-Dong, Seoul, Korea 153-782 www.heidenhain.co.kr	US	HEIDENHAIN CORPORATION Schaumburg, IL 60173-5337, USA www.heidenhain.com
CA	HEIDENHAIN CORPORATION Mississauga, Ontario L5T2N2, Canada www.heidenhain.com	MX	HEIDENHAIN CORPORATION MEXICO 20235 Aguascalientes, Ags., Mexico E-mail: info@heidenhain.com	VE	Maquinaria Diekmann S.A. Caracas, 1040-A, Venezuela E-mail: purchase@diekmann.com.ve
CH	HEIDENHAIN (SCHWEIZ) AG 8603 Schwerzenbach, Switzerland www.heidenhain.ch	MY	ISOSERVE SDN. BHD. 43200 Balakong, Selangor E-mail: isoserve@po.jaring.my	VN	AMS Co. Ltd HCM City, Vietnam E-mail: davidgoh@amsvn.com
CN	DR. JOHANNES HEIDENHAIN (CHINA) Co., Ltd. Beijing 101312, China www.heidenhain.com.cn	NL	HEIDENHAIN NEDERLAND B.V. 6716 BM Ede, Netherlands www.heidenhain.nl	ZA	MAFEMA SALES SERVICES C.C. Midrand 1685, South Africa www.heidenhain.co.za
CZ	HEIDENHAIN s.r.o. 102 00 Praha 10, Czech Republic www.heidenhain.cz	NO	HEIDENHAIN Scandinavia AB 7300 Orkanger, Norway www.heidenhain.no		
DK	TPTEKNIK A/S 2670 Greve, Denmark www.tp-gruppen.dk	PH	Machinebanks Corporation Quezon City, Philippines 1113 E-mail: info@machinebanks.com		

