



HEIDENHAIN



HEIDENHAIN Motors

for Axis and Spindle Drives

**Information for the
Machine Tool Builder**

September 2017

Motors for axis and spindle drives

HEIDENHAIN supplies motors for axis and spindle drives as accessories to its controls with integrated inverter. This brochure provides an overview of all the available motors and contains technical data and mating dimensions. For commissioning, please request the *Inverter Systems and Motors* Technical Manual.

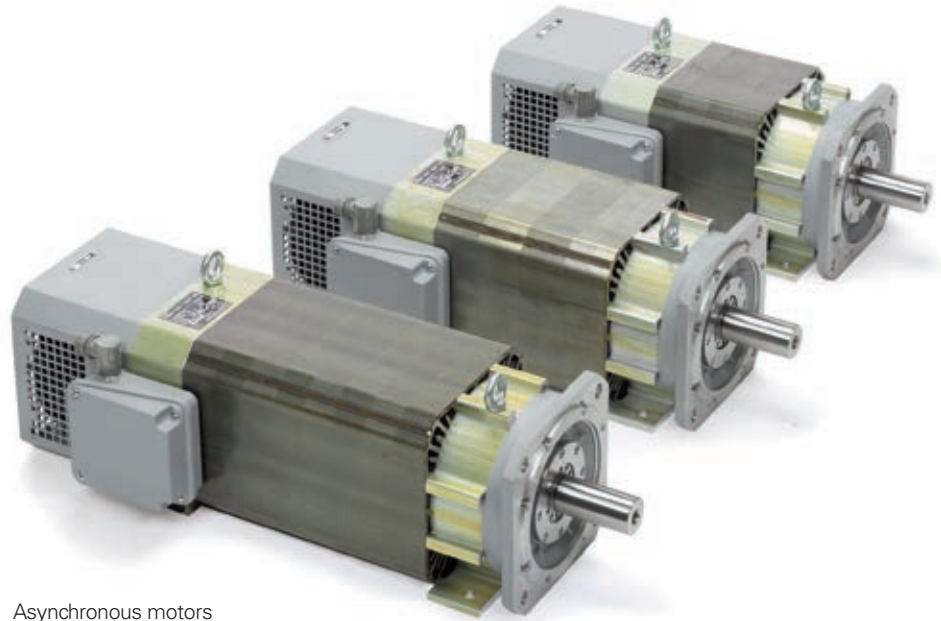

Asynchronous motors
for main spindles



Synchronous motors for feed drives

Intended use

The products described in this brochure

- may be used only for NC controlled machine tools
- should be operated only with controls and inverters from HEIDENHAIN. Consult with HEIDENHAIN before using other controls or inverters
- must be used only in an industrial environment, for commercial applications and in research facilities
- may be operated only in accordance with the product specifications (technical data, ambient data, safety instructions, etc.)

For the use of the devices as part of a safety function, the machine manufacturer must ensure that the end product meets all requirements of the Machinery Directive (2006/42/EC).

Improper use

The devices are not intended for applications in areas where a failure would result in considerable risks for humans or the environment. Use in potentially explosive atmospheres is prohibited.

Expendable parts

HEIDENHAIN motors contain components that are subject to wear, depending on the application and handling. These include in particular the following parts:

- Bearings
- Brakes
- Shaft sealing rings
- Fans

This catalog supersedes all previous editions, which thereby become invalid. The basis for ordering from HEIDENHAIN is always the catalog edition valid when the order is made.

Standards (ISO, EN, etc.) apply only where explicitly stated in the catalog.

Contents

Synchronous motors	Overview QSY			4
	Specifications	Series	QSY 96	6
		Series	QSY 116 QSY 116 EcoDyn	8
		Series	QSY 130 EcoDyn	10
		Series	QSY 155	12
		Series	QSY 155 EcoDyn	14
		Series	QSY 190 EcoDyn	16
		Series	QSY 260 EcoDyn	18
		QSY torque characteristics		
	Cables and connectors			23
Asynchronous motors	Overview QAN			24
	Specifications	Series	QAN 200	26
		Series	QAN 260	28
		Series	QAN 320	30
			QAN 200UH	32
		Series	QAN 260xH	34
		QAN power and torque characteristics		
	Cables			41
Accessories	Toroidal cores			42
Torque motors for direct drives				43

Synchronous motors

QSY overview

General technical information

Synchronous motors from HEIDENHAIN fulfill all requirements of a numerically controlled machine tool. Some special characteristics include

- an excellent running smoothness,
- an appropriate mass moment of inertia,
- a very good ratio of the rated torque to the stall torque,
- and a low torque ripple

Specifications

The specifications and the characteristic curves apply to motors mounted without thermal insulation. The temperature of the winding may differ from the maximum permissible ambient temperature of 40 °C by a maximum of 100 K. If the motor is mounted so that it is thermally insulated, the motor torque must be reduced in order to avoid thermal overloading. For motors with ECN 1313 or EQN 1325 absolute rotary encoders, the rated torque is reduced by 10 %.

Speed measurement

Synchronous motors from HEIDENHAIN operate with sinusoidal commutation. An integrated rotary encoder from HEIDENHAIN measures the rotor position and shaft speed. The following versions are available (see *Specifications*):

- ERN 1387 incremental encoder with \sim 1 V_{PP} interface, or
- ECN 1313 absolute singleturn rotary encoder with EnDat2.2/01 interface (only one motor revolution can be evaluated), or
- EQN 1325 absolute multiturn rotary encoder with EnDat2.2/01 interface

Mechanical life

The service life of the bearings depends on the shaft load and the average shaft speed (see the Technical Manual *Inverter Systems and Motors*).

For QSY motors, the nominal bearing service life—which depends on the specific motor and applies for a certain maximum shaft load at an average shaft speed—is 30 000 hours.

EcoDyn motors

Motors of the EcoDyn series are characterized by reduced current consumption together with higher rated torque and a max. permissible rated speed of 3000 rpm (QSY 260: 2000 rpm). The following controls are required in order to drive the motors in EcoDyn mode:

- iTNC 530
- TNC 640
- TNC 620
- MANUALplus 620
- CNC PILOT 640

For all other controls, the rated speed is 2000 rpm.

Electronic ID label

The synchronous motors with ECN 1313 or EQN 1325 feature an electronic ID label to make commissioning and diagnosis easier. The information, such as motor designation, ID number or serial number, stored in this ID label can be read and displayed by the internal diagnostic function DriveDiag of HSCI controls. Thus, the control automatically recognizes the motor type every time it is switched on.

Functional safety

All current QSY motor variants described here feature a fault exclusion against loosening of the mechanical connection between the encoder and the motor. This prevents any unintended loosening of the rotor and stator coupling.

You can receive information on the safety parameters of the motors or the encoders installed in it (e.g. MTTF values, data on fault exclusion) upon request.

Installation elevation

The maximum altitude for installation of HEIDENHAIN motors is 1000 m above sea level. For installation altitudes above 1000 m, additional cooling measures are required.

Mechanical data

Design IM B5 (mounting via flange) as per EN 60034-7

Mounting of the motor

The following screws are recommended for securing the motor:

QSY 96	M6
QSY 116	M8
QSY 130	M8
QSY 155	M10
QSY 190	M12
QSY 260	M16

Flange: Dimensions as per DIN EN 50347 and IEC 60072-1

Protection as per EN 60 529

Motor: IP65

Shaft exit: IP64

Suitability with regard to gear drive

Only for enclosed gear drives. The shaft is suitable only for dry connection.

Vibration severity

Grade N as per IEC 60 034-14

Radial runout, concentricity and axial runout

Tolerance N as per IEC 60072-1 (DIN 42955)

Shaft end

Cylindrical **without keyway** as per IEC 60072-1 with center hole and thread

Upon request:

Shaft **with keyway** and feather key as per DIN 6885-1

- QSY 96: A 6 x 6 x 32
- QSY 116: A 8 x 7 x 40
- QSY 130: A 8 x 7 x 40
- QSY 155: A 10 x 8 x 50
- QSY 190: A 10 x 8 x 70
- QSY 260: A 14 x 9 x 70

The motors with machine key are flush machine key balanced as per ISO 21 940-32.

Bearings free of maintenance

Holding brake optionally with low backlash $\leq 1^\circ$

Thermal specifications

Natural cooling

Temperature monitoring with KTY 84-130 thermistor in the stator winding

Thermal class F

Synchronous motors	Stall torque	Stall current	Rated speed	Recommended inverters ²⁾				Page
				1-axis module	2-axis module	Compact inverters/axis		
						UR 2xx D UE 2xx B	UE 1xx	
QSY 96A	1.5 Nm	1.5 A	4500 rpm	UM 111 D	UM 121 D	1 to 4	1 to 4	6
QSY 96G	5.2 Nm	5.2 A	4500 rpm	UM 111 D	UM 121 D	1 to 4	1 to 4	
QSY 116C	5.2 Nm	3.3 A	3000 rpm	UM 111 D	UM 121 D	1 to 4	1 to 4	8
QSY 116E	7.2 Nm	4.8 A	3000 rpm	UM 111 D	UM 121 D	1 to 4	4	
QSY 116J	10.0 Nm	6.8 A	3000 rpm	UM 111 D	UM 121 D	1 to 4	4	
QSY 116J EcoDyn	10.0 Nm	5.0 A	3000 rpm	UM 111 D	UM 121 D	1 to 4	4	
QSY 130C EcoDyn	6.0 Nm	3.0 A	3000 rpm	UM 111 D	UM 121 D	1 to 4	1 to 4	10
QSY 130E EcoDyn	9.0 Nm	4.5 A	3000 rpm	UM 111 D	UM 121 D	1 to 4	1 to 4	
QSY 155B	13.0 Nm	9.1 A	3000 rpm	UM 111 BD	UM 121 BD	4	–	12
QSY 155C	17.7 Nm	11.8 A	3000 rpm	UM 111 BD	UM 121 BD	4	–	
QSY 155D	21.6 Nm	14.6 A	3000 rpm	UM 111 BD	UM 121 BD	4	–	
QSY 155F	26.1 Nm	18.0 A	3000 rpm	UM 112 D	UM 122 D	4 ¹⁾	–	
QSY 155B EcoDyn	13.0 Nm	6.5 A	3000 rpm	UM 111 D	UM 121 D	1 to 4	–	14
QSY 155C EcoDyn	17.7 Nm	8.5 A	3000 rpm	UM 111 BD	UM 121 BD	4	–	
QSY 155D EcoDyn	21.6 Nm	10.6 A	3000 rpm	UM 111 BD	UM 121 BD	4	–	
QSY 155F EcoDyn	26.1 Nm	12.8 A	3000 rpm	UM 111 BD	UM 121 BD	4	–	
QSY 190C EcoDyn	28.0 Nm	14.0 A	3000 rpm	UM 111 BD	UM 121 BD	4	–	16
QSY 190D EcoDyn	38.0 Nm	18.1 A	3000 rpm	UM 112 D	UM 122 D	4 ¹⁾	–	
QSY 190F EcoDyn	47.6 Nm	22.7 A	3000 rpm	UM 112 D	UM 122 D	4 ¹⁾	–	
QSY 190K EcoDyn	62.5 Nm	29.8 A	3000 rpm	UM 113 D	–	–	–	
QSY 260B EcoDyn	85.0 Nm	31.0 A	2000 rpm	UM 114 D	–	–	–	18
QSY 260C EcoDyn	120 Nm	43.5 A	2000 rpm	UM 115 D	–	–	–	

¹⁾ Only UE 242B, UR 242D

²⁾ The maximum acceleration of the motor might not be achievable with the recommended inverters. If necessary, a more powerful power module must be selected.

Synchronous motors

QSY 96 series

Feed motors with 3 pole pairs
 Stall torque 1.5 Nm and 5.2 Nm
 Choice of incremental or absolute rotary encoder



Motor	QSY 96A		QSY 96G	
Rated voltage U_N	310 V/308 V		291 V/290 V	
Rated power output P_N	0.5 kW/0.45 kW		1.4 kW/1.3 kW	
Rated speed n_N	4500 rpm			
Rated torque $M_N^{1)}$	1.05 Nm/0.95 Nm		3.0 Nm/2.7 Nm at 4500 rpm	
Rated current $I_N^{1)}$	1.1 A/1.0 A		3.3 A/3.0 A	
Stall torque $M_0^{1)}$	1.5 Nm		5.2 Nm	
Stall current $I_0^{1)}$	1.5 A		5.2 A	
Max. speed n_{max}	6000 rpm			
Max. torque $M_{max}^{2)}$	5.5 Nm		22 Nm	
Max. current $I_{max}^{2)}$	6.3 A		25.4 A	
Mass m	3.6 kg	4.5 kg	7.2 kg	8.1 kg
Rotor inertia J	1.8 kgcm ²	2.1 kgcm ²	6.3 kgcm ²	6.6 kgcm ²
Brake Rated voltage U_{Br} Rated current I_{Br} Holding torque M_{Br}	Without – – –	With DC 24 V 0.5 A 5.0 Nm	Without – – –	With DC 24 V 0.5 A 5.0 Nm
ID For motor with ERN 1387 For motor with ECN 1313 For motor with EQN 1325	344512-0C 344512-8C 344512-5C	344512-0D 344512-8D 344512-5D	339875-0C 339875-8C 339875-5C	339875-0D 339875-8D 339875-5D

¹⁾ At 100 K ²⁾ Max. 200 ms

Italics: Data for motors with ECN 1313 or EQN 1325 (rated torque reduced by 10 %)

Rotatable connections

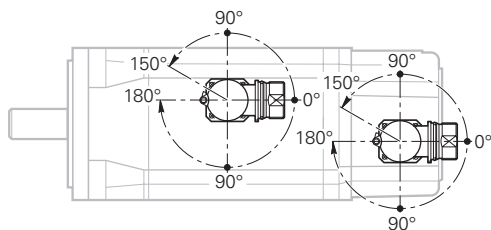

Power connector

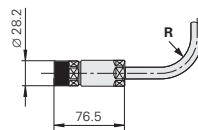

Encoder connector

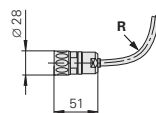

For **R** see page 23

QSY 96A Without brake

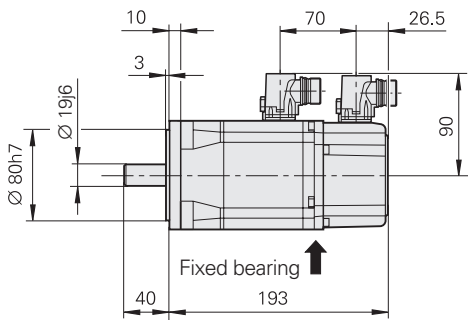

With brake

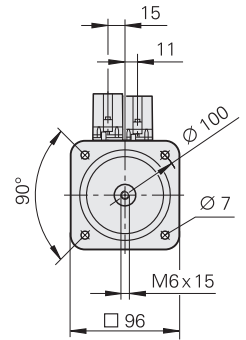
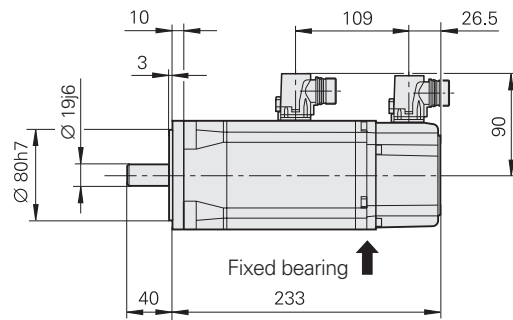

QSY 96G Without brake

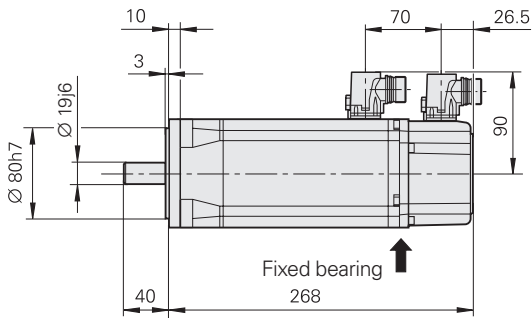

With brake

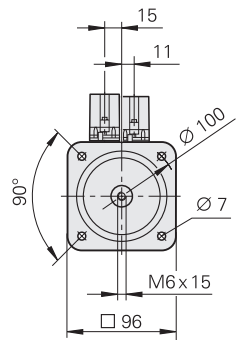
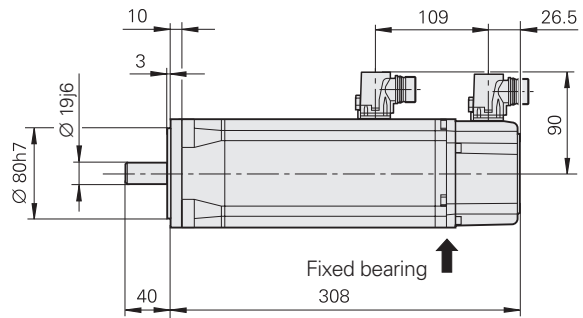

mm

 Tolerancing ISO 8015
 ISO 2768 - m H
 ≤ 6 mm: ± 0.2 mm

Synchronous motors

QSY 116 series

Feed motors with 3 pole pairs

Stall torque 5.2 Nm to 10 Nm

Choice of incremental or absolute rotary encoder



Motor	QSY 116C		QSY 116E		QSY 116J		QSY 116J EcoDyn	
Rated voltage U_N	315 V/311 V		302 V/299 V		290 V/288 V		408 V/405 V	
Rated power output P_N	1.45 kW/1.30 kW		1.85 kW/1.67 kW		2.42 kW/2.18 kW		2.64 kW/2.38 kW	
Rated speed n_N	3000 rpm						3000 rpm ³⁾	
Rated torque M_N ¹⁾	4.6 Nm/4.1 Nm		5.9 Nm/5.3 Nm		7.7 Nm/6.9 Nm		8.4 Nm/7.6 Nm	
Rated current I_N ¹⁾	3.3 A/3.0 A		4.1 A/3.7 A		5.4 A/4.8 A		4.3 A/3.9 A	
Stall torque M_0 ¹⁾	5.2 Nm		7.2 Nm		10.0 Nm		10.0 Nm	
Stall current I_0 ¹⁾	3.3 A		4.8 A		6.8 A		5.0 A	
Max. speed n_{max}	5400 rpm						4200 rpm ³⁾	
Max. torque M_{max} ²⁾	16 Nm		25 Nm		41 Nm		41 Nm	
Max. current I_{max} ²⁾	12.7 A		19.0 A		32.6 A		23.0 A	
Mass m	6.9 kg	7.8 kg	8.6 kg	9.5 kg	12.0 kg	13.3 kg	12.0 kg	13.3 kg
Rotor inertia J	7.5 kgcm ²	7.9 kgcm ²	9.9 kgcm ²	10.3 kgcm ²	15.0 kgcm ²	15.4 kgcm ²	15.0 kgcm ²	15.4 kgcm ²
Brake	Without	With	Without	With	Without	With	Without	With
Rated voltage U_{Br}	–	DC 24 V	–	DC 24 V	–	DC 24 V	–	DC 24 V
Rated current I_{Br}	–	0.6 A	–	0.6 A	–	0.85 A	–	0.85 A
Holding torque M_{Br}	–	13.5 Nm	–	13.5 Nm	–	13.5 Nm	–	13.5 Nm
ID								
For motor with ERN 1387	339876-0C	339876-0D	339877-0C	339877-0D	339878-0C	339878-0D	339878-1C	339878-1D
For motor with ECN 1313	339876-8C	339876-8D	339877-8C	339877-8D	–	–	339878-8C	339878-8D
For motor with EQN 1325	339876-5C	339876-5D	339877-5C	339877-5D	339878-5C	339878-5D	339878-6C	339878-6D

¹⁾ At 100 K ²⁾ Max. 200 ms ³⁾ In EcoDyn mode

Italics: Data for motors with ECN 1313 or EQN 1325 (rated torque reduced by 10 %)

Rotatable connections

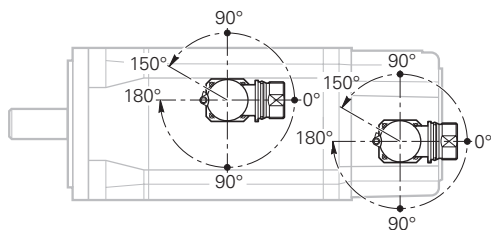

Power connector

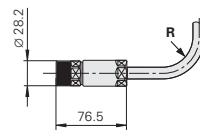

Encoder connector

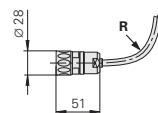

For **R** see page 23

QSY 116C Without brake

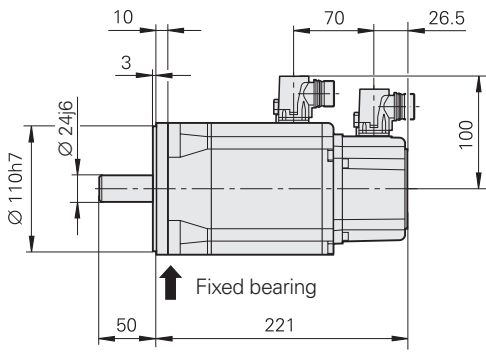

With brake

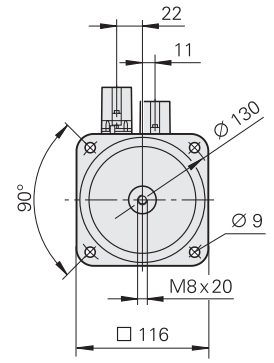
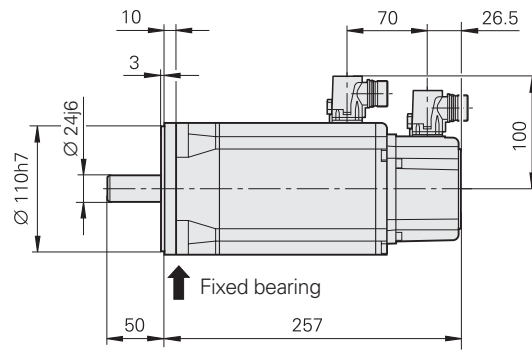

QSY 116E Without brake

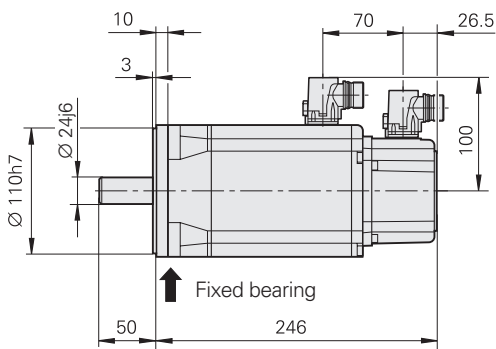

With brake

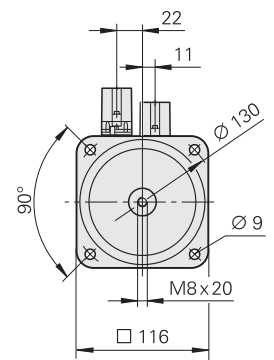
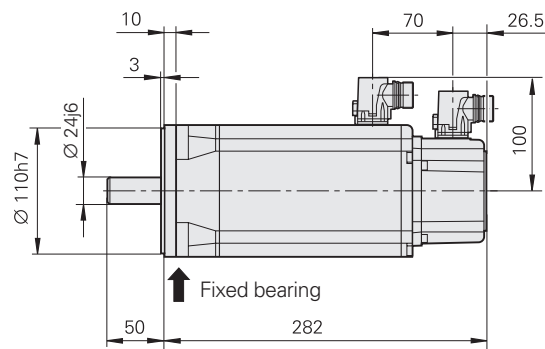

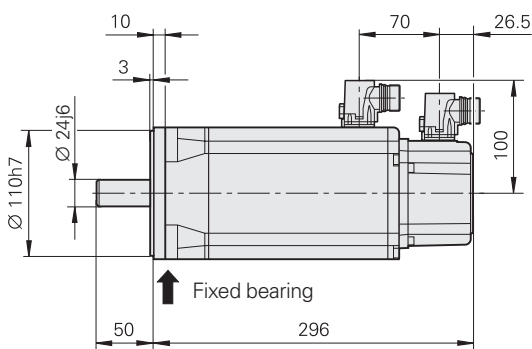

QSY 116J

QSY 116J EcoDyn Without brake

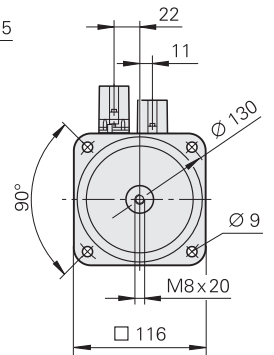
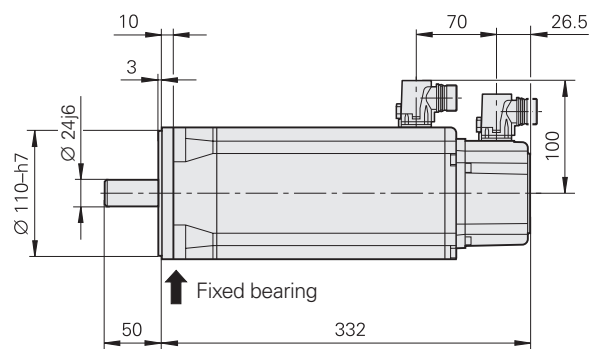

With brake



mm

 Tolerancing ISO 8015
 ISO 2768 - m H
 ≤ 6 mm: ±0.2 mm

Synchronous motors

QSY 130 EcoDyn series

Feed motors with 4 pole pairs
 Stall torque 6 Nm and 9 Nm
 Choice of incremental or absolute rotary encoder



Motor	QSY 130C EcoDyn		QSY 130E EcoDyn	
Rated voltage U_N	415 V/411 V		407 V/403 V	
Rated power output P_N	1.6 kW/1.5 kW		2.3 kW/2.1 kW	
Rated speed n_N	3000 rpm (in EcoDyn mode)			
Rated torque $M_N^{1)}$	5.2 Nm/4.7 Nm		7.4 Nm/6.7 Nm	
Rated current $I_N^{1)}$	2.7 A/2.4 A		3.8 A/3.4 A	
Stall torque $M_0^{1)}$	6.0 Nm		9.0 Nm	
Stall current $I_0^{1)}$	3.0 A		4.5 A	
Max. speed n_{max}	4200 rpm (in EcoDyn mode)			
Max. torque $M_{max}^{2)}$	16 Nm		23 Nm	
Max. current $I_{max}^{2)}$	8.6 A		12.7 A	
Mass m	7.9 kg	8.8 kg	9.7 kg	10.6 kg
Rotor inertia J	16.0 kgcm ²	16.4 kgcm ²	21.0 kgcm ²	21.4 kgcm ²
Brake Rated voltage U_{Br} Rated current I_{Br} Holding torque M_{Br}	Without – – –	With DC 24 V 0.6 A 13.5 Nm	Without – – –	With DC 24 V 0.6 A 13.5 Nm
ID For motor with ERN 1387 For motor with ECN 1313 For motor with EQN 1325	389053-1C 389053-8C 389053-6C	389053-1D 389053-8D 389053-6D	388422-1C 388422-8C 388422-6C	388422-1D 388422-8D 388422-6D

¹⁾ At 100 K ²⁾ Max. 200 ms

Italics: Data for motors with ECN 1313 or EQN 1325 (rated torque reduced by 10 %)

Rotatable connections

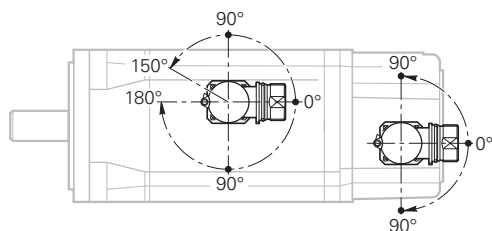

Power connector

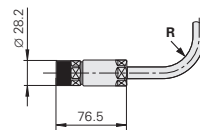

Encoder connector

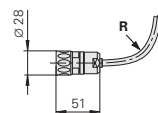

For **R** see page 23

QSY 130C Without brake

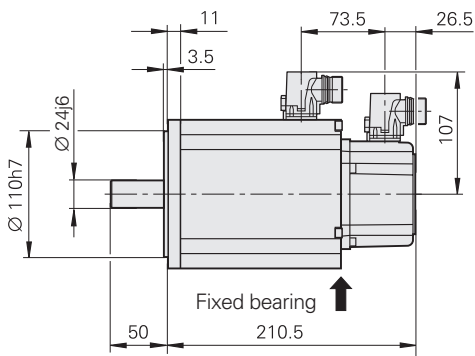

With brake

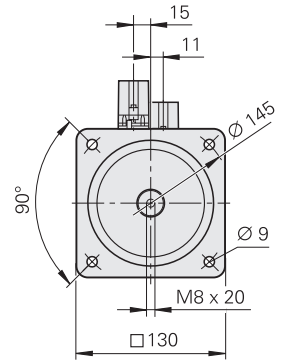
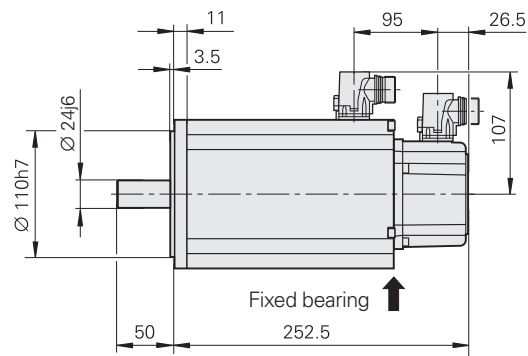

QSY 130E Without brake

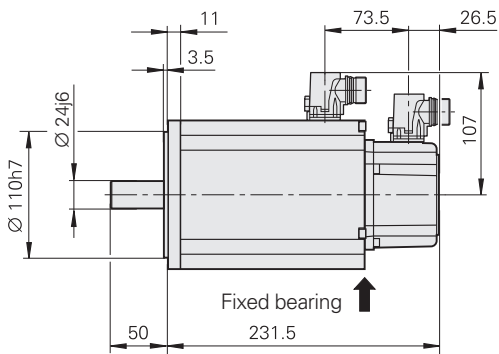

With brake

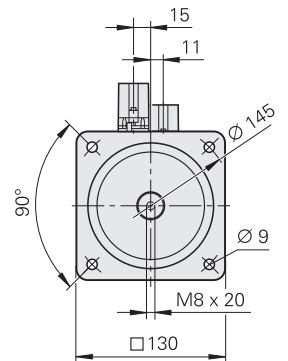
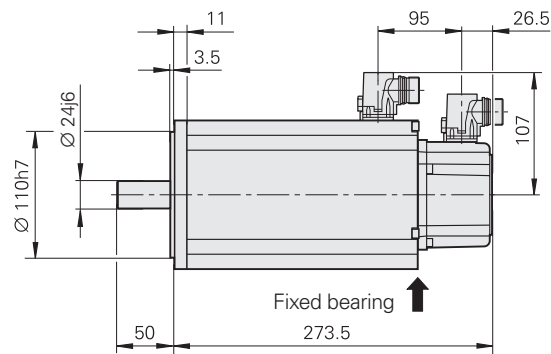

mm

 Tolerancing ISO 8015
 ISO 2768 - m H
 ≤ 6 mm: ±0.2 mm

Synchronous motors

QSY 155 series

Feed motors with 4 pole pairs

Stall torque 13 Nm to 26.1 Nm

Choice of incremental or absolute rotary encoder



Motor	QSY 155 B		QSY 155 C		QSY 155 D		QSY 155 F	
Rated voltage U_N	298 V/295 V		294 V/291 V		293 V/291 V		289 V/287 V	
Rated power output P_N	2.9 kW/2.6 kW		3.9 kW/3.5 kW		4.6 kW/4.1 kW		5.2 kW/4.7 kW	
Rated speed n_N	3000 rpm							
Rated torque $M_N^{1)}$	9.2 Nm/8.3 Nm		12.5 Nm/11.3 Nm		14.8 Nm/13.3 Nm		16.7 Nm/15.0 Nm	
Rated current $I_N^{1)}$	6.9 A/6.2 A		8.7 A/7.8 A		10.6 A/9.5 A		12.0 A/10.8 A	
Stall torque $M_0^{1)}$	13.0 Nm		17.7 Nm		21.6 Nm		26.1 Nm	
Stall current $I_0^{1)}$	9.1 A		11.8 A		14.6 A		18.0 A	
Max. speed n_{max}	5000 rpm							
Max. torque $M_{max}^{2)}$	39 Nm		52 Nm		64 Nm		90 Nm	
Max. current $I_{max}^{2)}$	29.7 A		38.9 A		49.5 A		68.6 A	
Mass m	15.0 kg	18.0 kg	17.5 kg	20.5 kg	20.0 kg	23.0 kg	25.0 kg	28.0 kg
Rotor inertia J	33 kgcm ²	35 kgcm ²	43 kgcm ²	45 kgcm ²	54 kgcm ²	56 kgcm ²	75 kgcm ²	77 kgcm ²
Brake	Without	With	Without	With	Without	With	Without	With
Rated voltage U_{Br}	–	DC 24 V	–	DC 24 V	–	DC 24 V	–	DC 24 V
Rated current I_{Br}	–	1.04 A	–	1.04 A	–	1.04 A	–	1.04 A
Holding torque M_{Br}	–	40 Nm	–	40 Nm	–	40 Nm	–	40 Nm
ID								
For motor with ERN 1387	339880-0C	339880-0D	365308-0C	365308-0D	339881-0C	339881-0D	339882-0C	339882-0D
For motor with EQN 1325	339880-5C	339880-5D	365308-5C	365308-5D	339881-5C	339881-5D	339882-5C	339882-5D

¹⁾ At 100 K ²⁾ Max. 200 ms

Italics: Data for motors with EQN 1325 (rated torque reduced by 10 %)

Rotatable connections

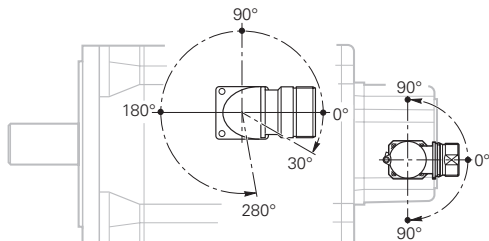

Power connector

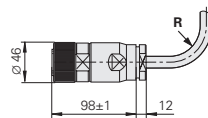

Encoder connector

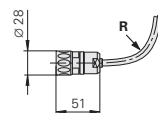

For **R** see page 23

QSY 155B Without brake

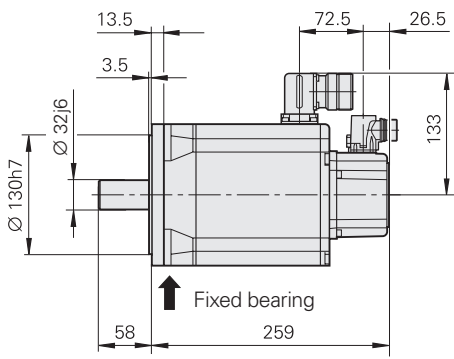

With brake

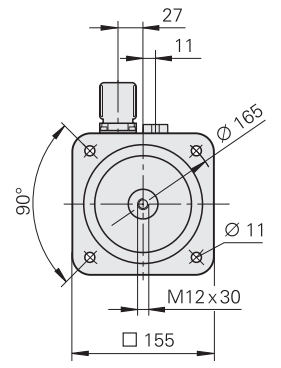
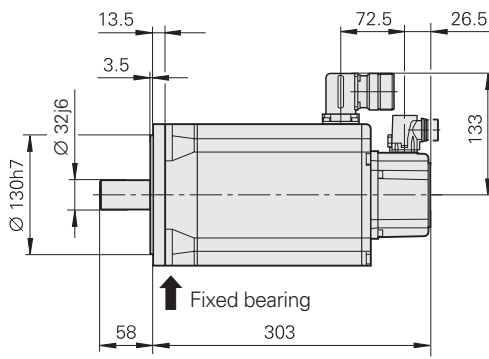

QSY 155C Without brake

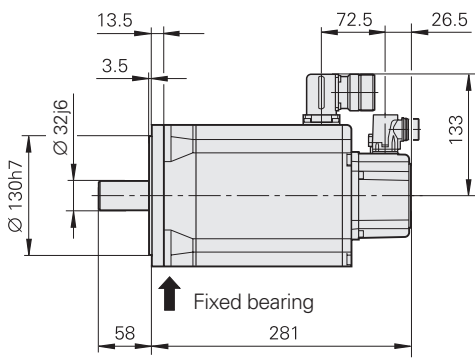

With brake

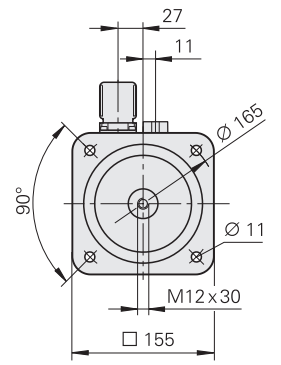
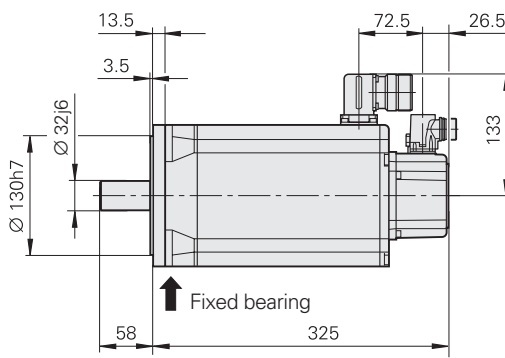

QSY 155D Without brake

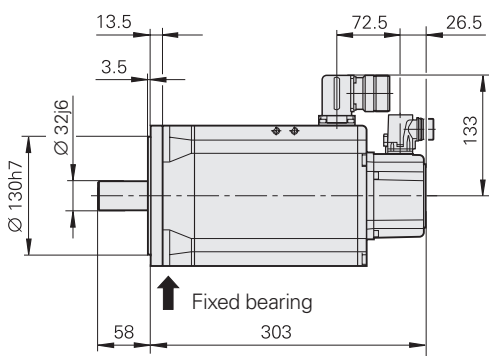

With brake

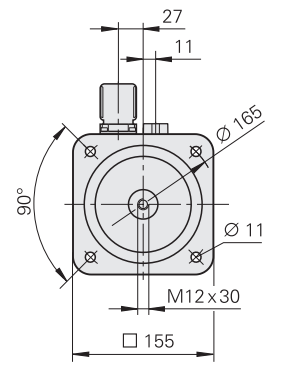
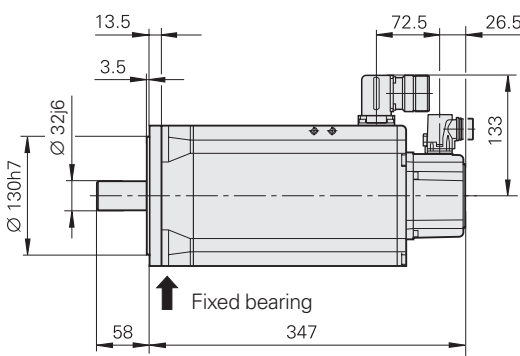

QSY 155F Without brake

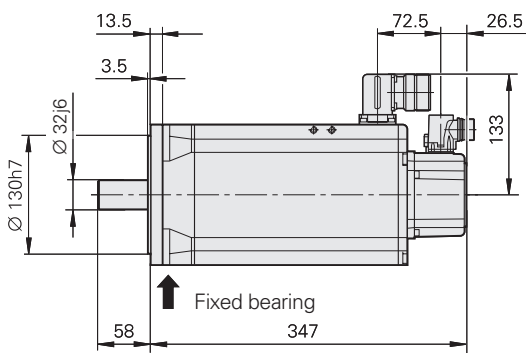

With brake

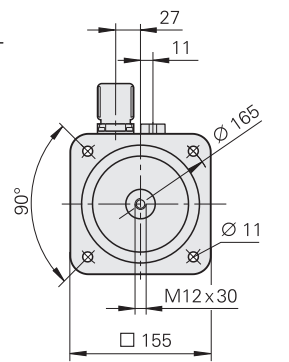
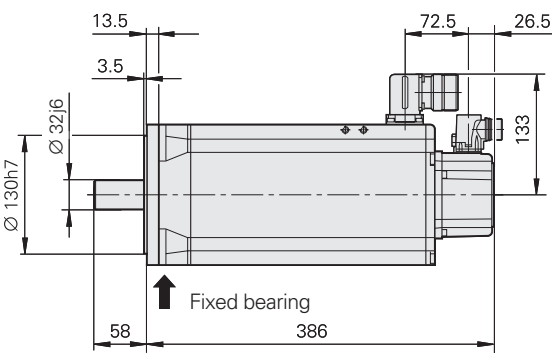

mm

 Tolerancing ISO 8015
 ISO 2768 - m H
 $\leq 6 \text{ mm}; \pm 0.2 \text{ mm}$

Synchronous motors

QSY 155 EcoDyn series

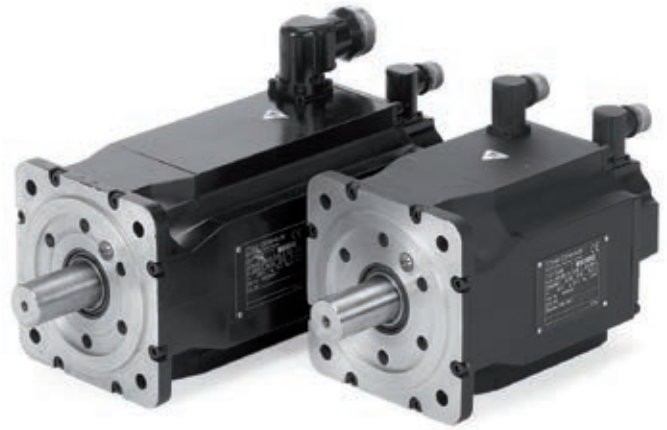
Feed motors with 4 pole pairs
 Stall torque 13 Nm to 26.1 Nm
 Choice of incremental or absolute rotary encoder



Motor	QSY 155B EcoDyn		QSY 155C EcoDyn		QSY 155D EcoDyn		QSY 155F EcoDyn	
Rated voltage U_N	417 V/412 V		420 V/415 V		412 V/407 V		399 V/397 V	
Rated power output P_N	3.5 kW/3.1 kW		5.0 kW/4.5 kW		5.7 kW/5.1 kW		6.0 kW/5.4 kW	
Rated speed n_N	3000 rpm (in EcoDyn mode)							
Rated torque $M_N^{1)}$	11.0 Nm/9.9 Nm		16.0 Nm/14.4 Nm		18.1 Nm/16.3 Nm		19.2 Nm/17.3 Nm	
Rated current $I_N^{1)}$	5.6 A/5.0 A		8.2 A/7.4 A		9.1 A/8.2 A		9.8 A/8.8 A	
Stall torque $M_0^{1)}$	13.0 Nm		17.7 Nm		21.6 Nm		26.1 Nm	
Stall current $I_0^{1)}$	6.5 A		8.5 A		10.6 A		12.8 A	
Max. speed n_{max}	4200 rpm (in EcoDyn mode)							
Max. torque $M_{max}^{2)}$	39 Nm		52 Nm		64 Nm		90 Nm	
Max. current $I_{max}^{2)}$	21.2 A		27.6 A		35.0 A		49.5 A	
Mass m	15.0 kg	18.0 kg	17.5 kg	20.5 kg	20.0 kg	23.0 kg	25.0 kg	28.0 kg
Rotor inertia J	33 kgcm ²	35 kgcm ²	43 kgcm ²	45 kgcm ²	54 kgcm ²	56 kgcm ²	75 kgcm ²	77 kgcm ²
Brake	Without	With	Without	With	Without	With	Without	With
Rated voltage U_{Br}	–	DC 24 V	–	DC 24 V	–	DC 24 V	–	DC 24 V
Rated current I_{Br}	–	1.04 A	–	1.04 A	–	1.04 A	–	1.04 A
Holding torque M_{Br}	–	40 Nm	–	40 Nm	–	40 Nm	–	40 Nm
ID								
For motor with ERN 1387	339880-1C	339880-1D	365308-1C	365308-1D	339881-1C	339881-1D	339882-1C	339882-1D
For motor with ECN 1313	339880-8C	339880-8D	365308-8C	365308-8D	339881-8C	339881-8D	339882-8C	339882-8D
For motor with EQN 1325	339880-6C	339880-6D	365308-6C	365308-6D	339881-6C	339881-6D	339882-6C	339882-6D

¹⁾ At 100 K ²⁾ Max. 200 ms

Italics: Data for motors with ECN 1313 or EQN 1325 (rated torque reduced by 10 %)

Rotatable connections

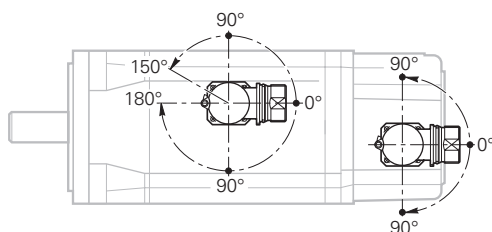

Power connector for QSY 155B/C/D EcoDyn

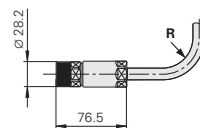

Power connector for QSY 155F EcoDyn

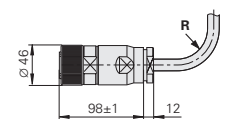

Encoder connector

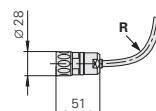

QSY 155B EcoDyn Without brake

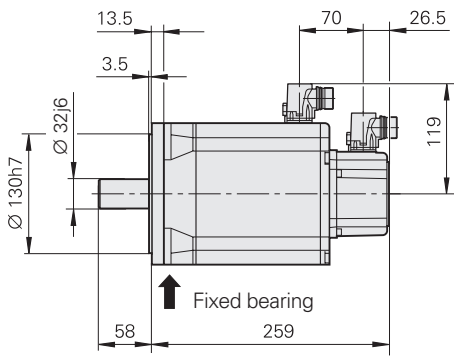

With brake

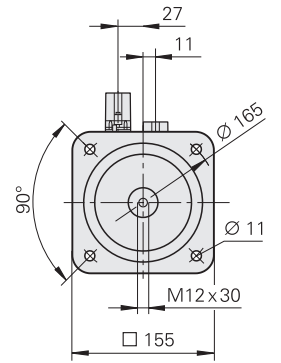
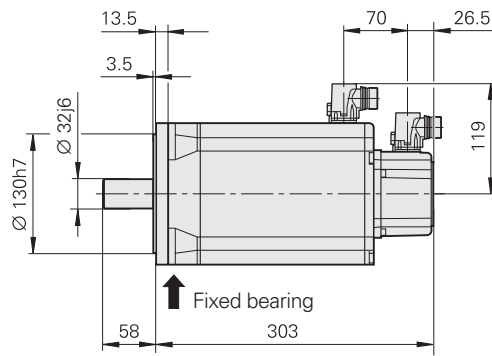

QSY 155C EcoDyn Without brake

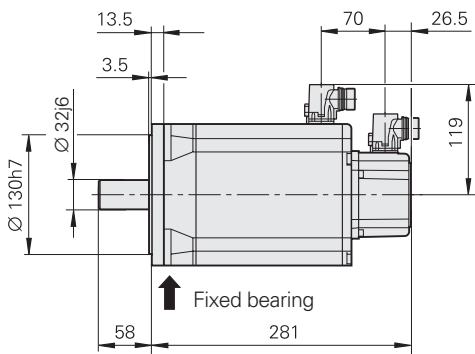

With brake

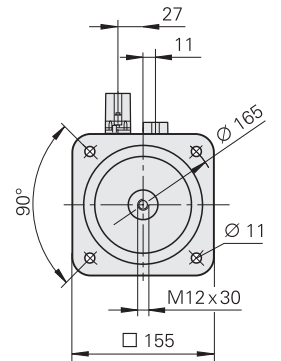
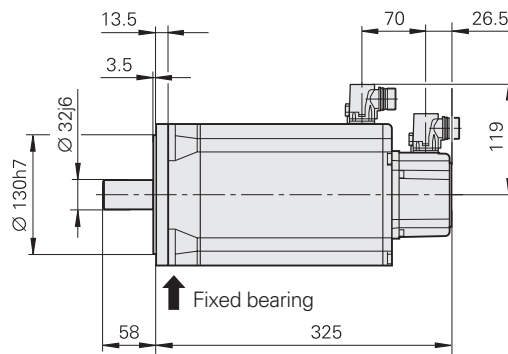

QSY 155D EcoDyn Without brake

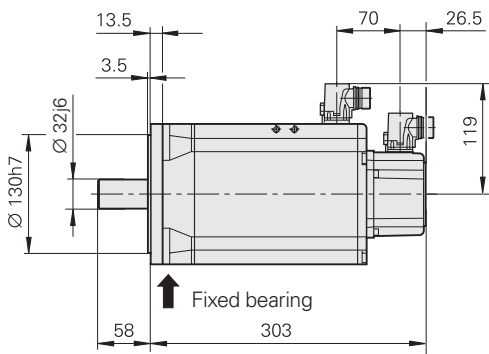

With brake

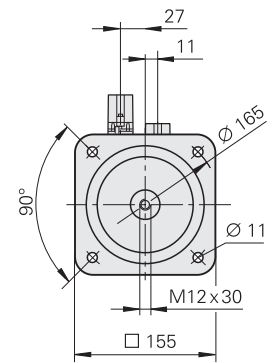
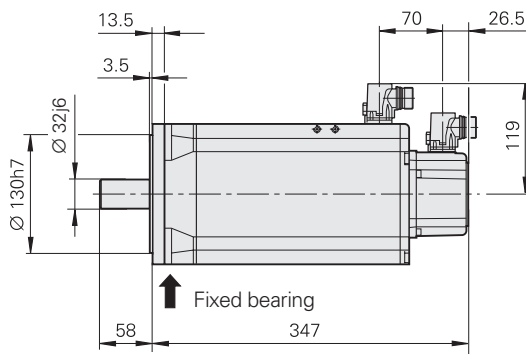

QSY 155F EcoDyn Without brake

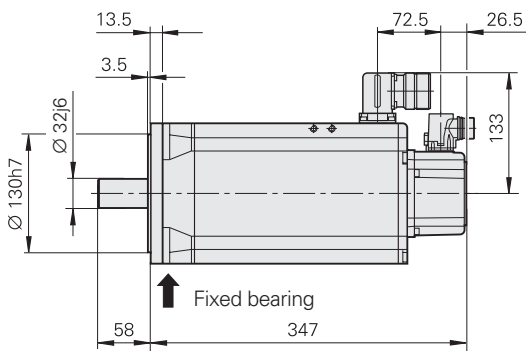

With brake

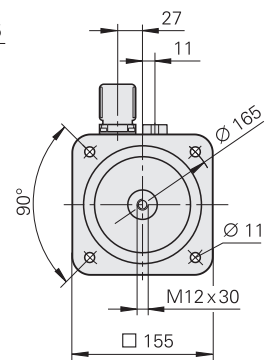
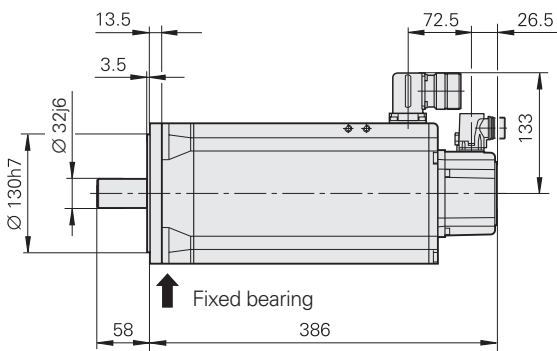

mm

 Tolerancing ISO 8015
 ISO 2768 - m H
 ≤ 6 mm: ±0.2 mm

Synchronous motors

QSY 190 EcoDyn series

Feed motors with 4 pole pairs
 Stall torque 28 Nm to 62.5 Nm
 Choice of incremental or absolute rotary encoder



Motor	QSY 190C EcoDyn		QSY 190D EcoDyn		QSY 190F EcoDyn		QSY 190K EcoDyn	
Rated voltage U_N	427 V/420 V		421 V/412 V		408 V/404 V		399 V/396 V	
Rated power output P_N	7.2 kW/6.5 kW		9.6 kW/8.6 kW		9.9 kW/8.9 kW		12.2 kW/11.0 kW	
Rated speed n_N	3000 rpm (in EcoDyn mode)							
Rated torque $M_N^{1)}$	23.0 Nm/20.7 Nm		30.6 Nm/27.5 Nm		31.5 Nm/28.4 Nm		39.0 Nm/35.1 Nm	
Rated current $I_N^{1)}$	11.8 A/10.6 A		14.4 A/13.0 A		15.0 A/13.5 A		20.2 A/18.2 A	
Stall torque $M_0^{1)}$	28.0 Nm		38.0 Nm		47.6 Nm		62.5 Nm	
Stall current $I_0^{1)}$	14.0 A		18.1 A		22.7 A		29.8 A	
Max. speed n_{max}	3900 rpm (in EcoDyn mode)							
Max. torque $M_{max}^{2)}$	85 Nm		107 Nm		150 Nm		240 Nm	
Max. current $I_{max}^{2)}$	50.2 A		62.9 A		88.4 A		134.3 A	
Mass m	29.0 kg	37.0 kg	33.5 kg	41.5 kg	42.5 kg	50.5 kg	61 kg	69.0 kg
Rotor inertia J	106 kgcm ²	115 kgcm ²	133 kgcm ²	142 kgcm ²	190 kgcm ²	199 kgcm ²	290 kgcm ²	299 kgcm ²
Brake	Without	With	Without	With	Without	With	Without	With
Rated voltage U_{Br}	–	DC 24 V	–	DC 24 V	–	DC 24 V	–	DC 24 V
Rated current I_{Br}	–	1.38 A	–	1.38 A	–	1.38 A	–	1.38 A
Holding torque M_{Br}	–	70 Nm	–	70 Nm	–	70 Nm	–	70 Nm
ID								
For motor with ERN 1387	392023-1C	392023-1D	392024-1C	392024-1D	388244-1C	388244-1D	392025-1C	392025-1D
For motor with ECN 1313	392023-8C	392023-8D	392024-8C	392024-8D	388244-8C	388244-8D	392025-8C	392025-8D
For motor with EQN 1325	392023-6C	392023-6D	392024-6C	392024-6D	388244-6C	388244-6D	392025-6C	392025-6D

¹⁾ At 100 K ²⁾ Max. 200 ms

Italics: Data for motors with ECN 1313 or EQN 1325 (rated torque reduced by 10 %)

Rotatable connections

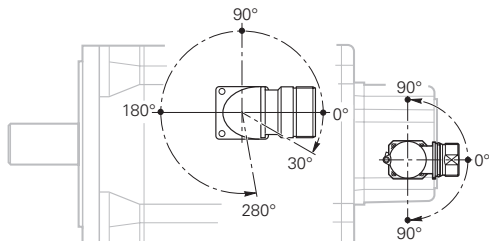

Power connector

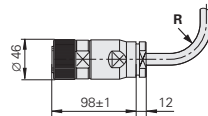

Encoder connector

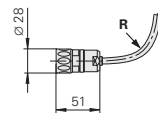

For **R** see page 23

QSY 190C EcoDyn Without brake

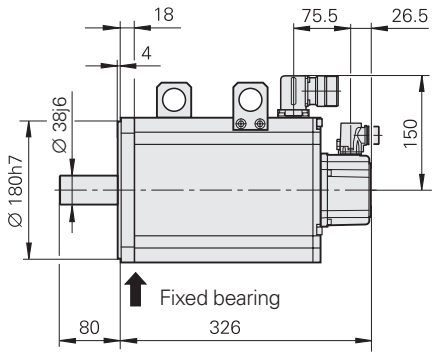

With brake

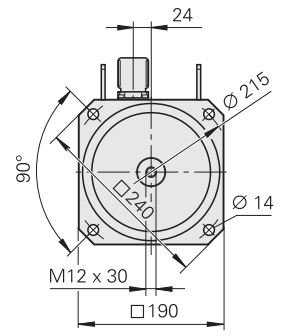
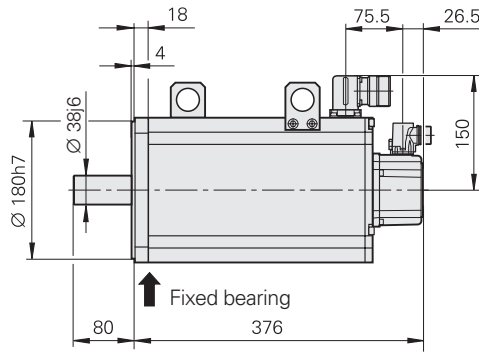

QSY 190D EcoDyn Without brake

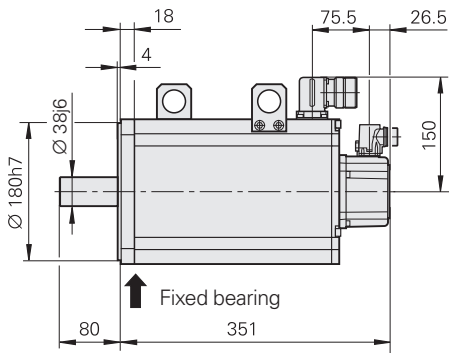

With brake

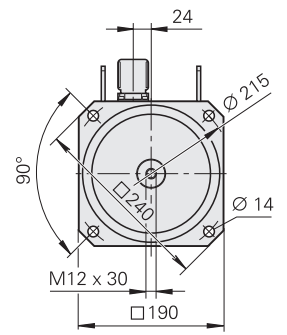
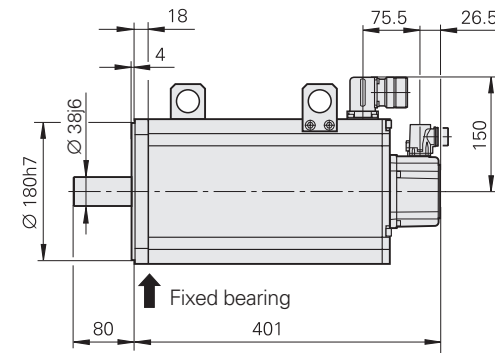

QSY 190F EcoDyn Without brake

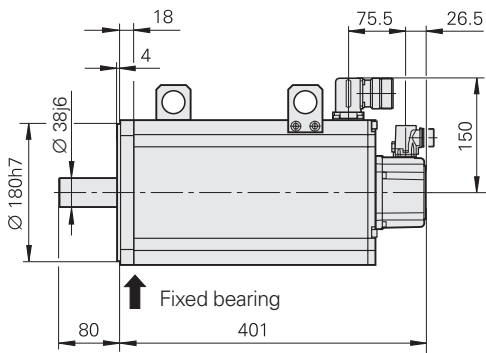

With brake

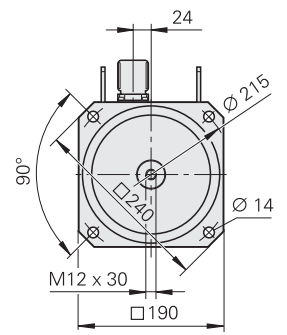
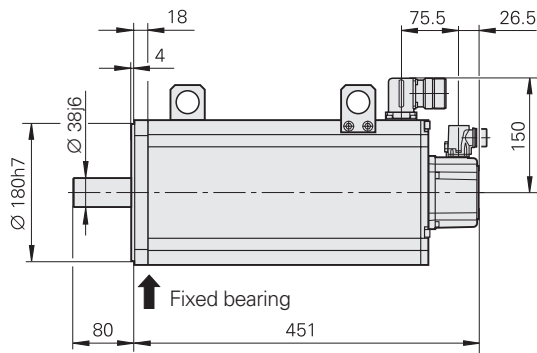

QSY 190K EcoDyn Without brake

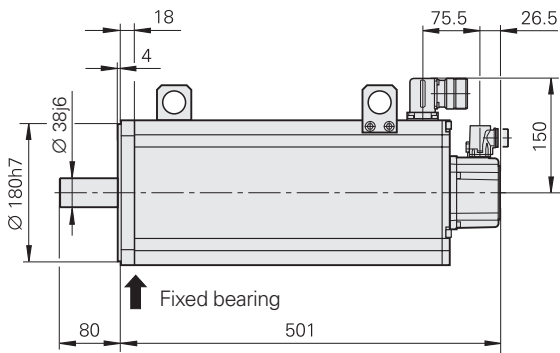

With brake

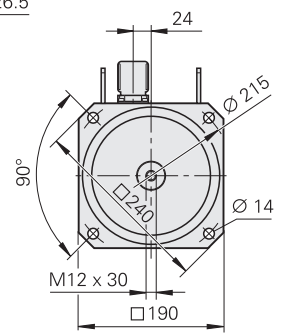
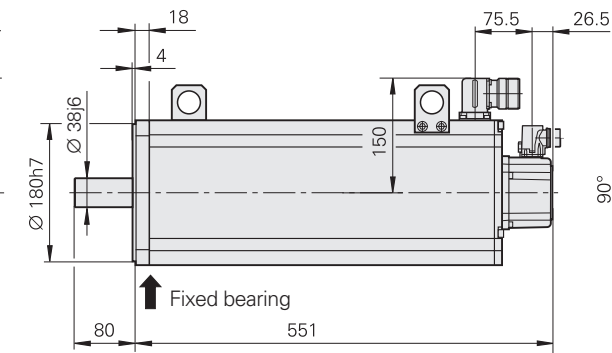

mm

 Tolerancing ISO 8015
 ISO 2768 - m H
 ≤ 6 mm: ± 0.2 mm

Synchronous motors

QSY 260 EcoDyn series

Feed motors with 4 pole pairs
 Stall torque 85 Nm to 120 Nm
 Choice of incremental or absolute rotary encoder



Motor	QSY 260B EcoDyn		QSY 260C EcoDyn	
Rated voltage U_N	352 V/350 V		376 V/373 V	
Rated power output P_N	12.0 kW/10.8 kW		16.0 kW/14.4 kW	
Rated speed n_N	2000 rpm (in EcoDyn mode)			
Rated torque $M_N^{1)}$	57.3 Nm/51.6 Nm		76.4 Nm/68.8 Nm	
Rated current $I_N^{1)}$	21.5 A/19.4 A		28 A/25.2 A	
Stall torque $M_0^{1)}$	85.0 Nm		120.0 Nm	
Stall current $I_0^{1)}$	31.0 A		43.5 A	
Max. speed n_{max}	3000 rpm (in EcoDyn mode)			
Max. torque $M_{max}^{2)}$	250 Nm		360 Nm	
Max. current $I_{max}^{2)}$	130.0 A		173.0 A	
Mass m	62.0 kg	75.0 kg	74.0 kg	87.0 kg
Rotor inertia J	357.0 kgcm ²	368.0 kgcm ²	538.0 kgcm ²	557.0 kgcm ²
Brake Rated voltage U_{Br} Rated current I_{Br} Holding torque M_{Br}	Without – – –	With DC 24 V 2.05 A 110 Nm	Without – – –	With DC 24 V 2.05 A 125 Nm
ID For motor with ERN 1387 For motor with EQN 1325	1110623-1C 1110623-6C	1110623-1D 1110623-6D	1100242-1C 1100242-6C	1100242-1D 1100242-6D

¹⁾ At 100 K ²⁾ Max. 200 ms

Italics: Data for motors with EQN 1325 (rated torque reduced by 10 %)

Rotatable connections

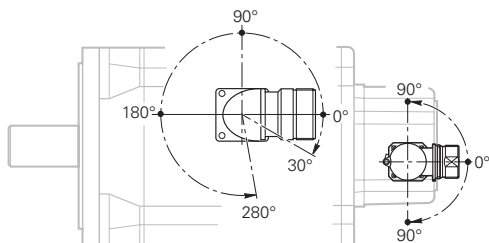

Power connector

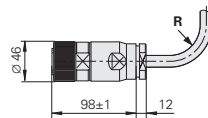

Encoder connector

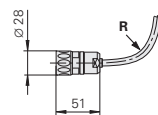

For **R** see page 23

QSY 260B Without brake

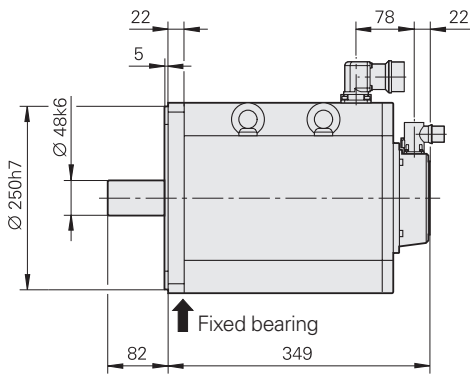

With brake

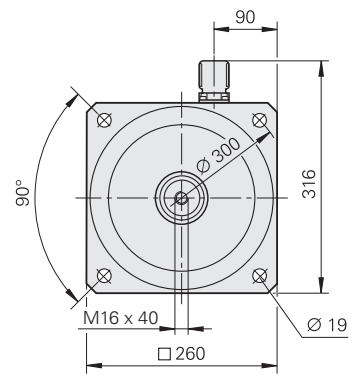
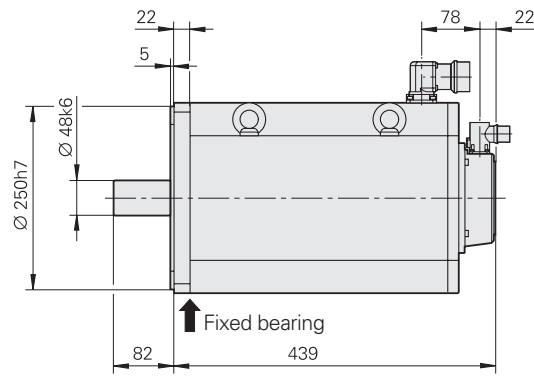

QSY 260C Without brake

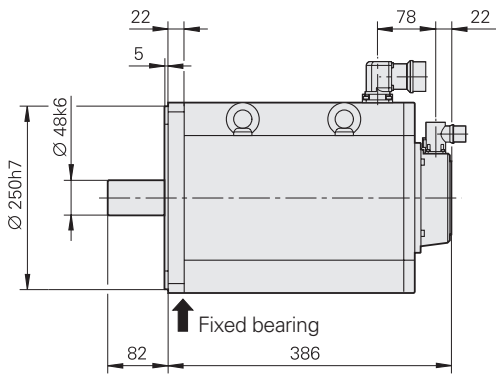

With brake

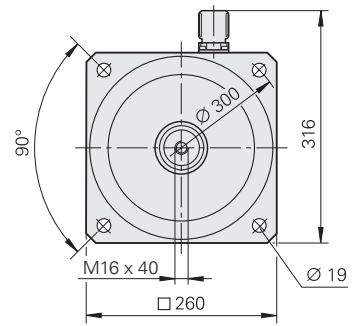
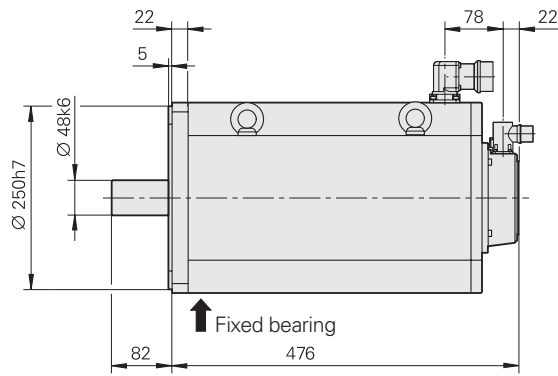

mm

 Tolerancing ISO 8015
 ISO 2768 - m H
 ≤ 6 mm: ± 0.2 mm

Synchronous motors

Torque characteristics

----- Characteristic curve according to the specifications
 ————— Measured characteristic curve of one motor

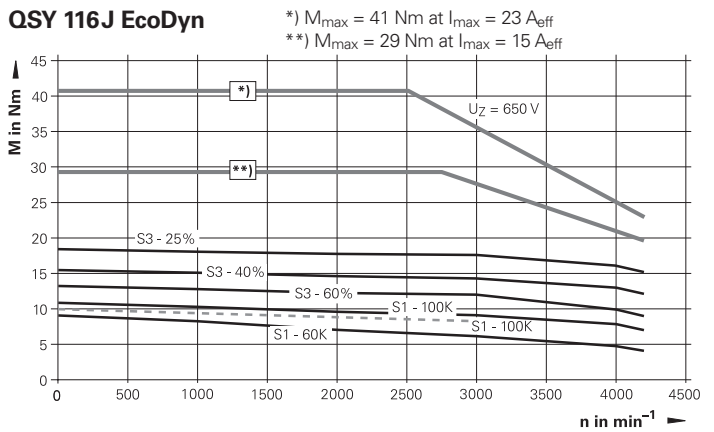
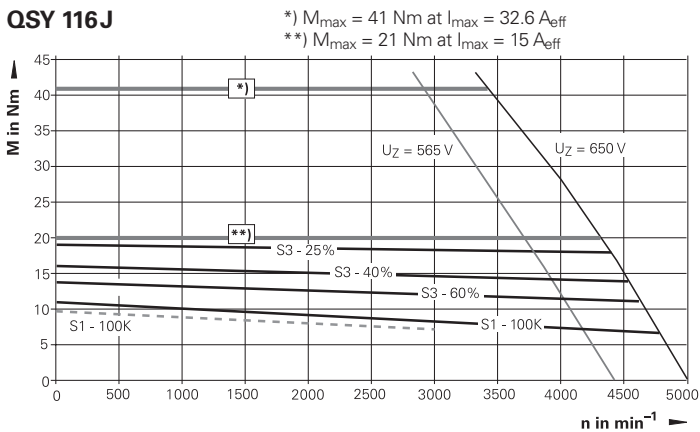
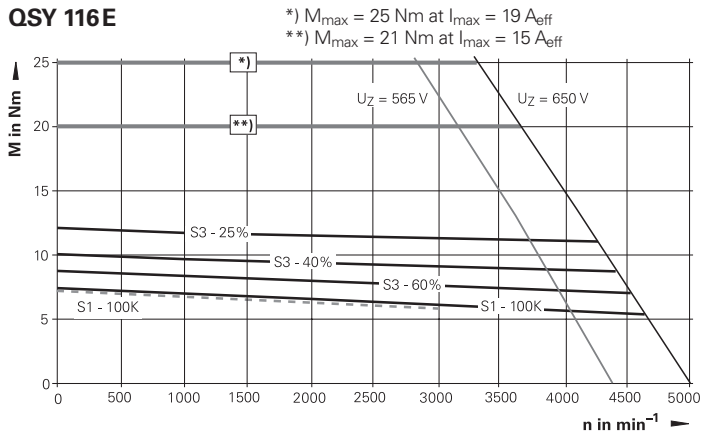
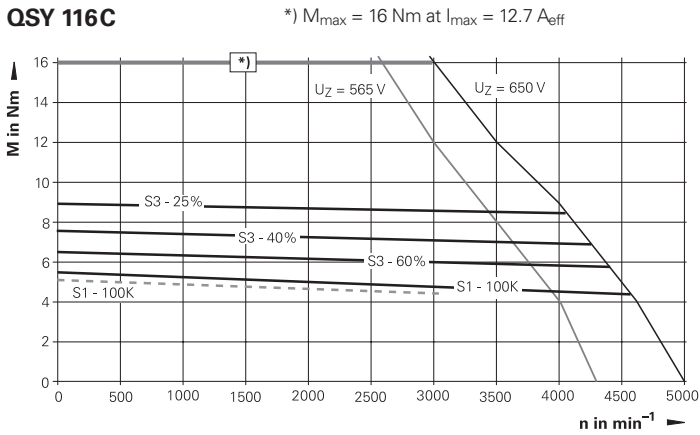
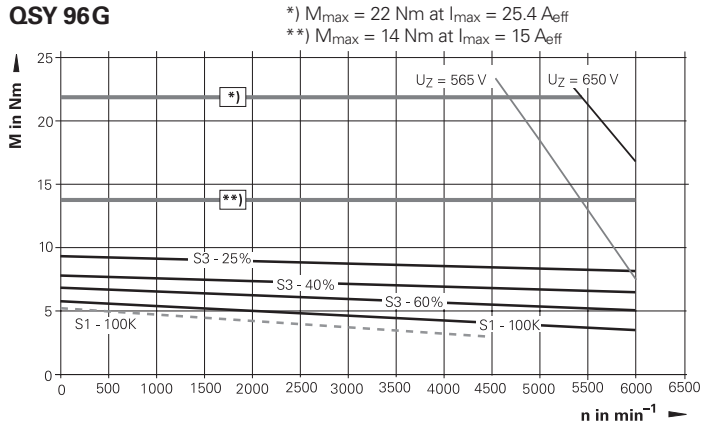
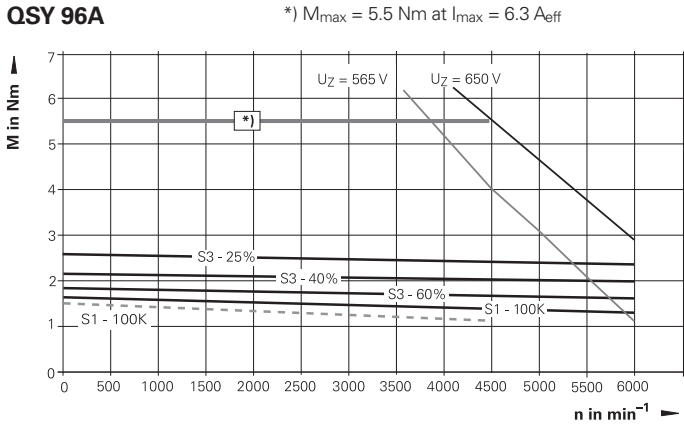
*) Characteristic curve at maximum motor current
 **) Characteristic curve with use of compact inverters



Notes

- The characteristic curves apply to motors with ERN 1387.
- S3 mode
 Cycle duration 10 minutes.
 In the rest period the motor must be stopped and disconnected from power.

QSY 130C EcoDyn

*) $M_{max} = 16 \text{ Nm}$ at $I_{max} = 8.6 \text{ A}_{eff}$
 **) $M_{max} = 14.5 \text{ Nm}$ at $I_{max} = 7.5 \text{ A}_{eff}$

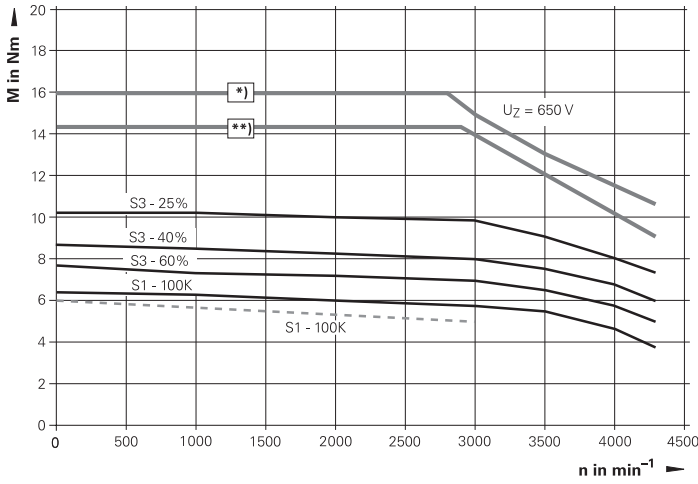

QSY 130E EcoDyn

*) $M_{max} = 23 \text{ Nm}$ at $I_{max} = 12.7 \text{ A}_{eff}$
 **) $M_{max} = 14.5 \text{ Nm}$ at $I_{max} = 7.5 \text{ A}_{eff}$

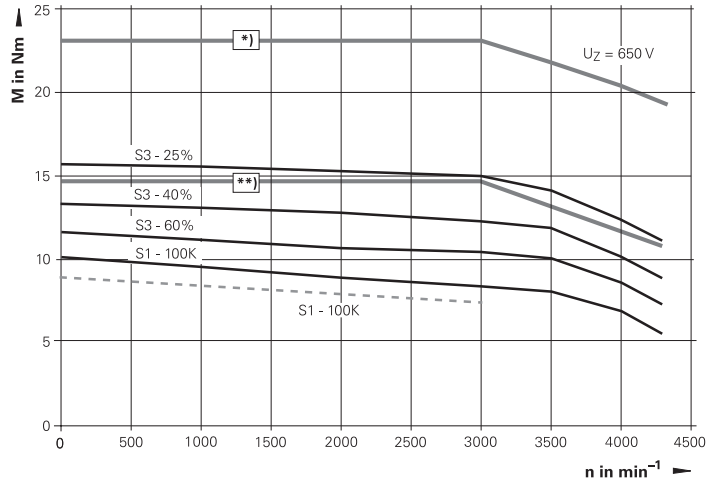

QSY 155B

*) $M_{max} = 39 \text{ Nm}$ at $I_{max} = 29.7 \text{ A}_{eff}$
 **) $M_{max} = 21 \text{ Nm}$ at $I_{max} = 15 \text{ A}_{eff}$

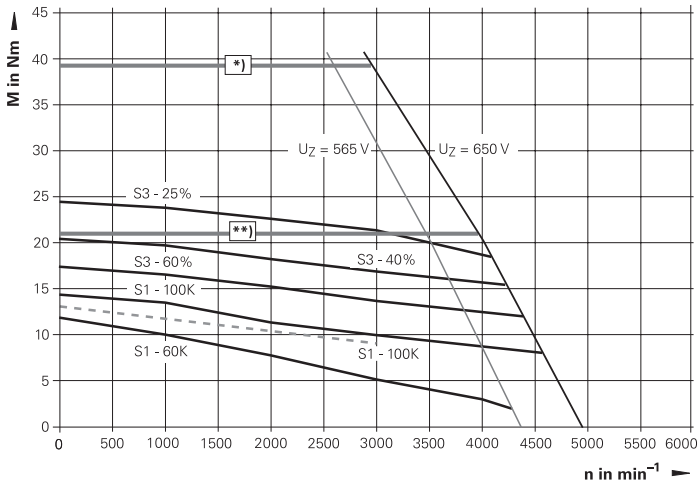

QSY 155B EcoDyn

*) $M_{max} = 39 \text{ Nm}$ at $I_{max} = 21.2 \text{ A}_{eff}$
 **) $M_{max} = 29 \text{ Nm}$ at $I_{max} = 15 \text{ A}_{eff}$

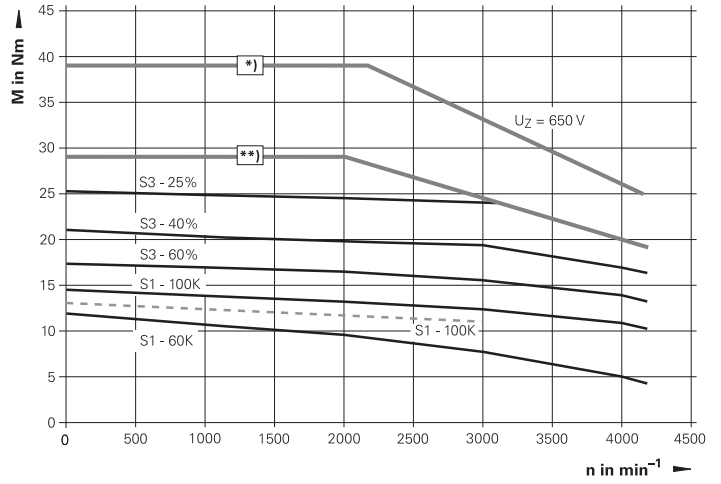

QSY 155C

*) $M_{max} = 52 \text{ Nm}$ at $I_{max} = 38.9 \text{ A}_{eff}$
 **) $M_{max} = 42 \text{ Nm}$ at $I_{max} = 30 \text{ A}_{eff}$

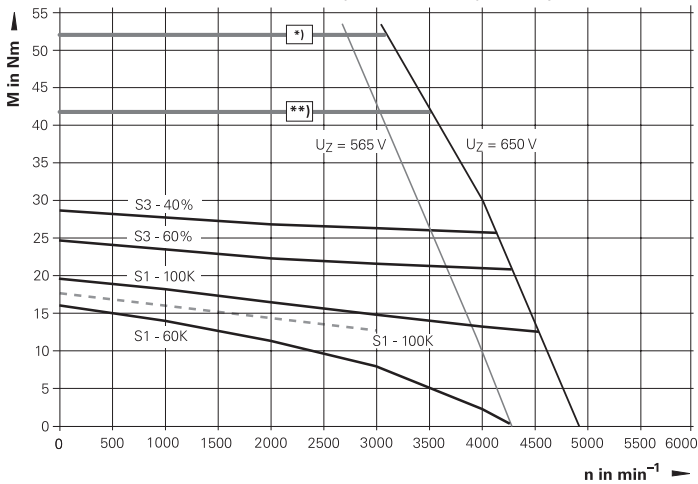

QSY 155C EcoDyn

*) $M_{max} = 52 \text{ Nm}$ at $I_{max} = 27.6 \text{ A}_{eff}$
 **) $M_{max} = 29 \text{ Nm}$ at $I_{max} = 15 \text{ A}_{eff}$

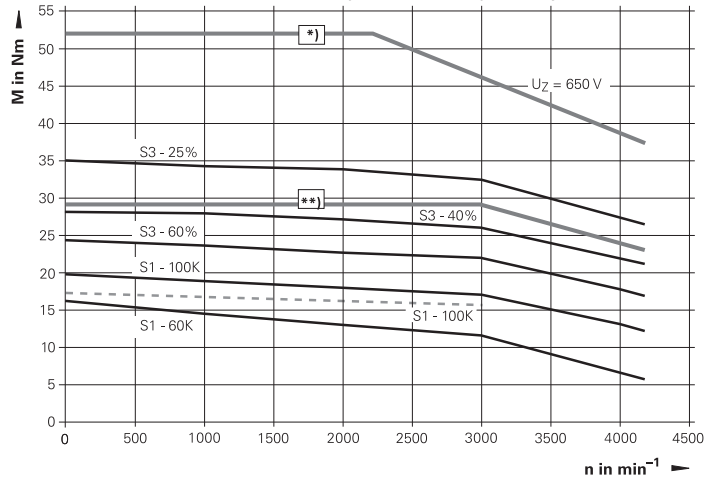

QSY 155D

*) $M_{max} = 64 \text{ Nm}$ at $I_{max} = 49.5 \text{ A}_{eff}$
 **) $M_{max} = 42 \text{ Nm}$ at $I_{max} = 30 \text{ A}_{eff}$

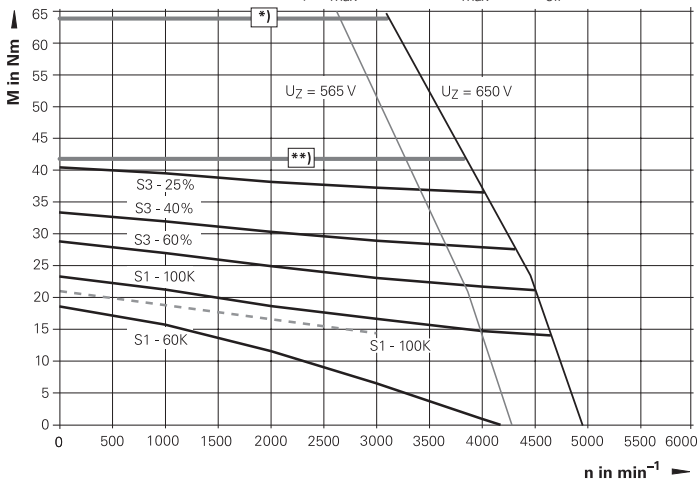

QSY 155D EcoDyn

*) $M_{max} = 64 \text{ Nm}$ at $I_{max} = 35 \text{ A}_{eff}$
 **) $M_{max} = 59 \text{ Nm}$ at $I_{max} = 30 \text{ A}_{eff}$

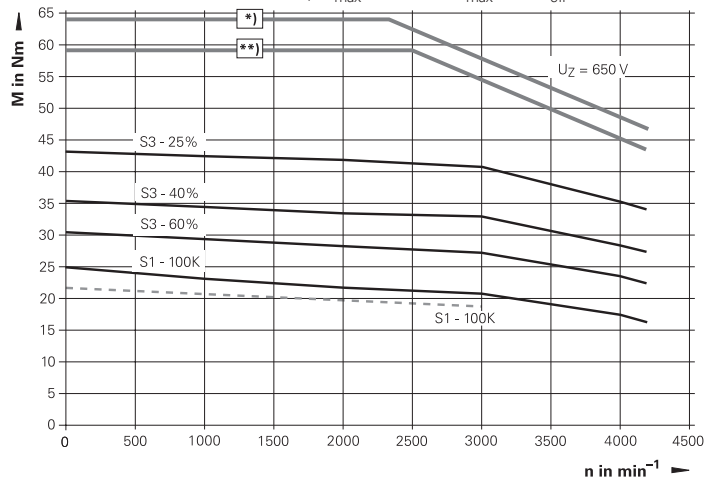

QSY 155F

*) $M_{max} = 90 \text{ Nm}$ at $I_{max} = 68.6 \text{ A}_{eff}$
 **) $M_{max} = 64 \text{ Nm}$ at $I_{max} = 46 \text{ A}_{eff}$

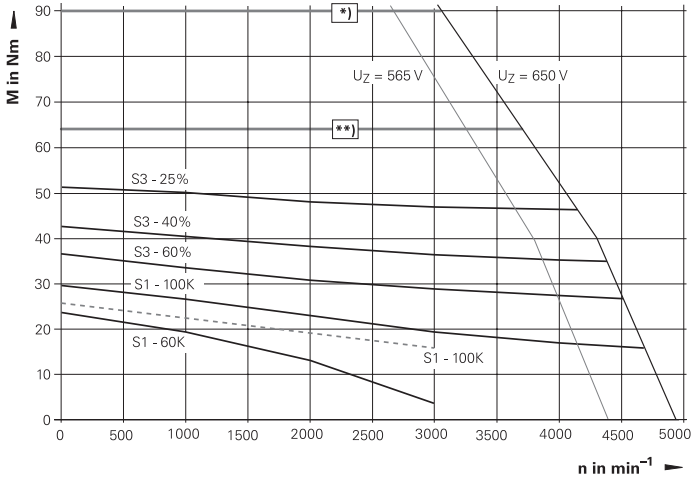

QSY 155F EcoDyn

*) $M_{max} = 90 \text{ Nm}$ at $I_{max} = 49.5 \text{ A}_{eff}$
 **) $M_{max} = 59 \text{ Nm}$ at $I_{max} = 30 \text{ A}_{eff}$

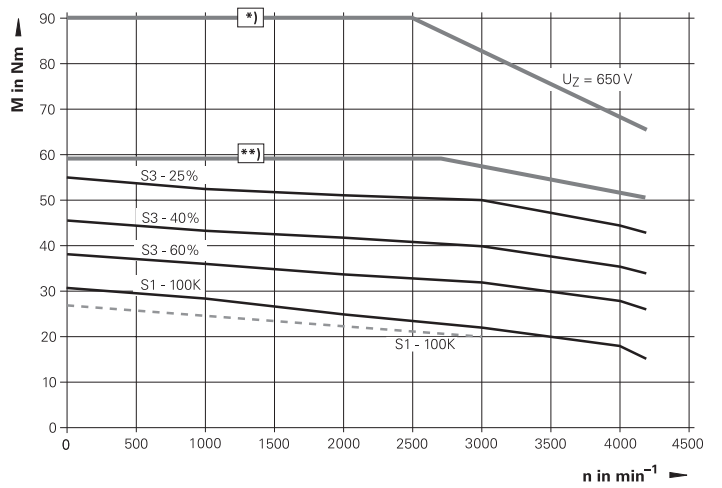

QSY 190C EcoDyn

*) $M_{max} = 85 \text{ Nm}$ at $I_{max} = 50.2 \text{ A}_{eff}$
 **) $M_{max} = 59 \text{ Nm}$ at $I_{max} = 30 \text{ A}_{eff}$

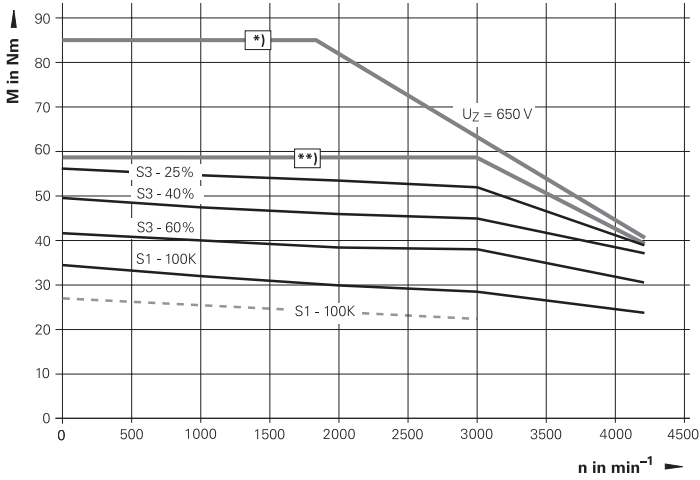

QSY 190D EcoDyn

*) $M_{max} = 107 \text{ Nm}$ at $I_{max} = 62.9 \text{ A}_{eff}$
 **) $M_{max} = 59 \text{ Nm}$ at $I_{max} = 30 \text{ A}_{eff}$

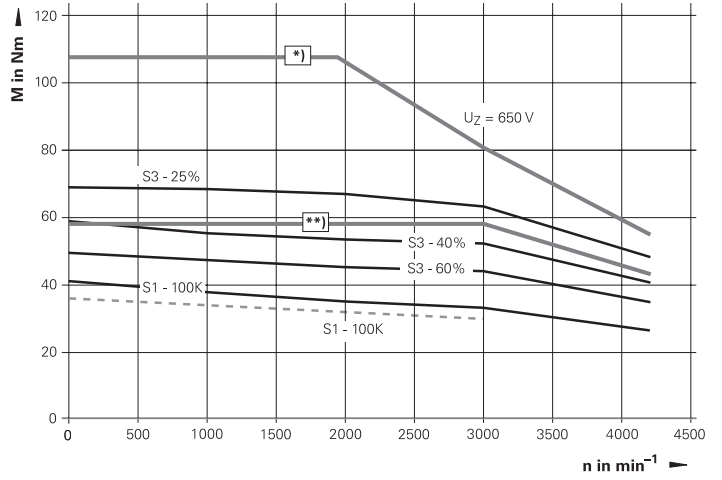

QSY 190F EcoDyn

*) $M_{max} = 150 \text{ Nm}$ at $I_{max} = 88.4 \text{ A}_{eff}$
 **) $M_{max} = 59 \text{ Nm}$ at $I_{max} = 30 \text{ A}_{eff}$

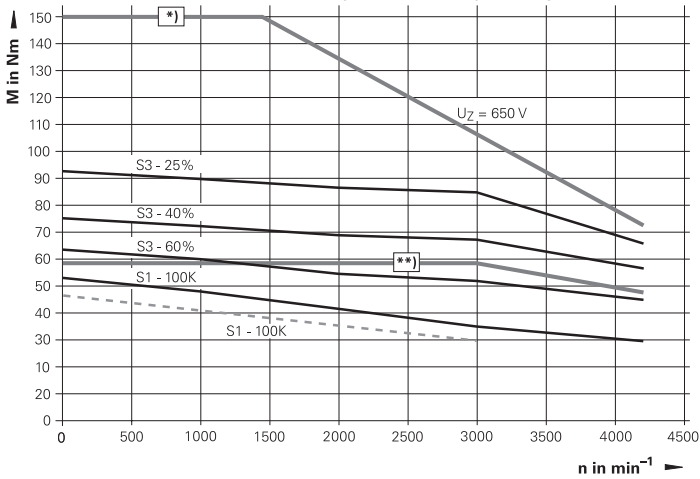

QSY 190K EcoDyn

*) $M_{max} = 240 \text{ Nm}$ at $I_{max} = 134.3 \text{ A}_{eff}$

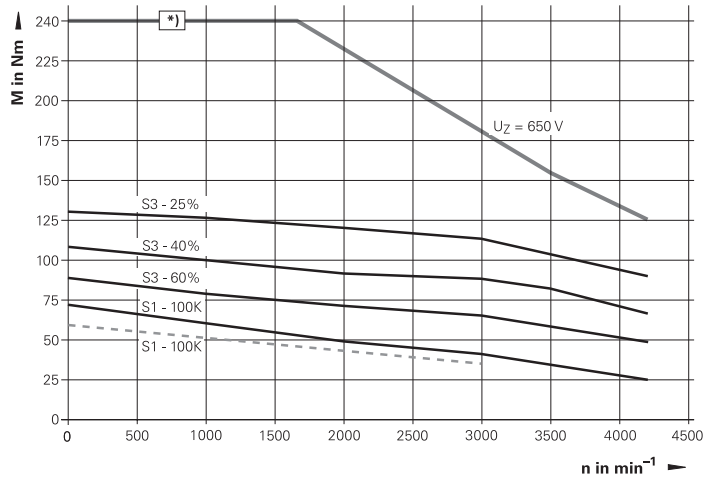

QSY 260B EcoDyn

*) $M_{max} = 250 \text{ Nm}$ at $I_{max} = 130 \text{ A}_{eff}$

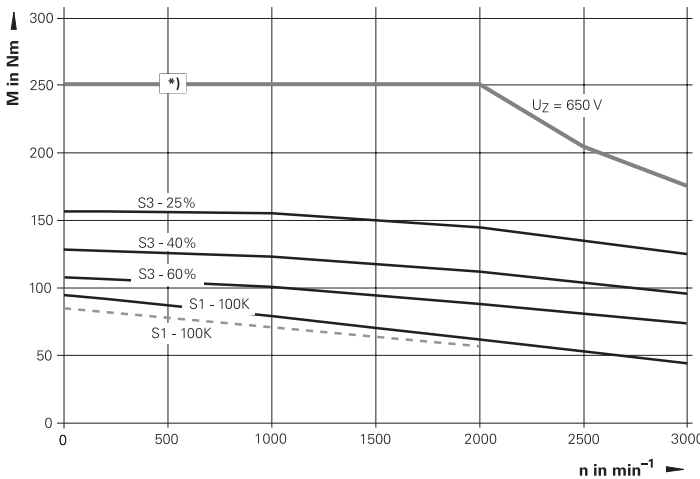

QSY 260C EcoDyn

*) $M_{max} = 360 \text{ Nm}$ at $I_{max} = 173 \text{ A}_{eff}$

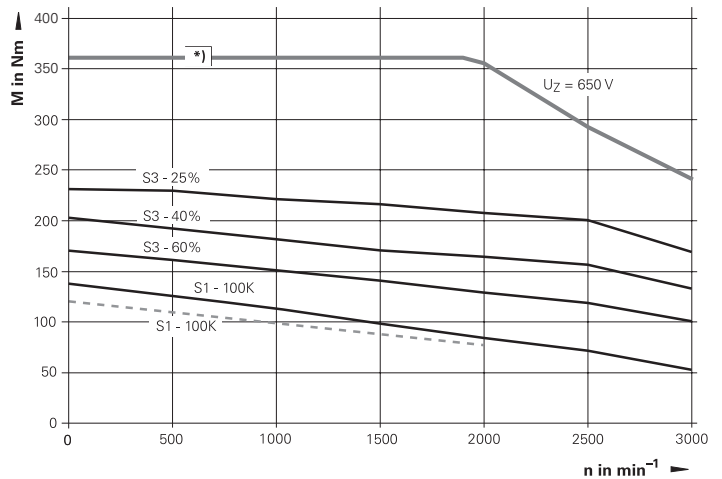

Synchronous motors

Cables and connectors

Power cables

Current load at ambient temperature up to 40 °C

	Cable with one connector ¹⁾ ID	Connector ID	Cable ²⁾ only ID	Bend radius R for frequent flexing	Cable type	Diameter
Current load up to 13.8 A						
QSY 96 QSY 116 QSY 130 QSY 155B EcoDyn QSY 155C EcoDyn QSY 155D EcoDyn	352960-xx <i>575796-xx</i>	325165-02	818792-xx <i>1214270-xx</i>	≥ 65 mm ≥ 105 mm	PUR [4 x 1.5 mm ² + (2 x 1.0 mm ²)]	13.0 mm <i>13.5 mm</i>
QSY 155B QSY 155C QSY 155F EcoDyn	352962-xx <i>690131-xx</i>	333090-02				
Current load up to 26.0 A						
QSY 155D QSY 155F QSY 190C EcoDyn QSY 190D EcoDyn QSY 190F EcoDyn	352963-xx <i>575797-xx</i>	333090-02	818791-xx <i>1214271-xx</i>	≥ 74 mm ≥ 123 mm	PUR [4 x 4 mm ² + (2 x 1.0 mm ²)]	14.8 mm <i>15.8 mm</i>
Current load up to 32.8 A						
QSY 190K EcoDyn QSY 260B EcoDyn	393570-xx <i>690141-xx</i>	333090-03	818790-xx <i>1214272-xx</i>	≥ 82 mm ≥ 132 mm	PUR [4 x 6 mm ² + (2 x 1.0 mm ²)]	16.4 mm <i>17.0 mm</i>
Current load up to 45.8 A						
QSY 260C EcoDyn	1119325-xx <i>1214663-xx</i>	333090-03	1214269-xx <i>1213905-xx</i>	≥ 104 mm ≥ 177 mm	PUR [4 x 10 mm ² + (2 x 1.0 mm ²)] <i>PUR [4 x 10 mm² + (2 x 1.5 mm²)]</i>	20.8 mm <i>23.5 mm</i>

¹⁾ Toroidal cores need to be used for cable lengths greater than 15 m (see page 47).

²⁾ Available only in the cable lengths 100 m, 150 m and 200 m

Italics: Shielded power cable

Encoder cable

	Cable length ¹⁾	Cable complete with connectors ID	Line drop compensator ID	Extension cable ID	Bend radius R for frequent flexing
QSY with ECN 1313 or EQN 1325	< 60 m	336376-xx	–	340302-xx (as required)	≥ 100 mm
QSY synchronous motor with ERN 1387	< 30 m	289440-xx	–	336847-xx (as required)	≥ 100 mm
	30 m to 60 m	289440-xx	370226-01	336847-xx	

¹⁾ Max. total cable length 60 m

Asynchronous motors

QAN overview

General technical information

Specifications

The specifications and the characteristic curves apply to motors mounted without thermal insulation. The temperature may differ from the maximum permissible ambient temperature of 40 °C by a maximum of 105 K. If the motor is mounted so that it is thermally insulated, the motor torque must be reduced in order to avoid thermal overloading.

Shaft bearing

HEIDENHAIN asynchronous motors are equipped with maintenance-free bearings. The shaft bearing on **motors with stub shaft** is optionally available as either standard bearing or as spindle bearing. The version with spindle bearing can withstand greater radial forces and allows higher spindle speeds. Motors with spindle bearing have a slightly larger overall length.

The **hollow-shaft motors** always have spindle bearings.

Mechanical life

The service life of the bearings depends on the shaft load and the average shaft speed (see the Technical Manual *Inverter Systems and Motors*).

For QAN motors, the nominal bearing service life—which depends on the specific motor and applies for a certain maximum shaft load at an average shaft speed—is 10000 hours.

Speed measurement

An integrated rotary encoder from HEIDENHAIN measures the shaft speed:

- ERN 1381 with 1024 lines, for motors with stub shaft
- ERM 280 with 600 lines, for motors with hollow shaft

Shaft end

HEIDENHAIN QAN asynchronous motors have a cylindrical shaft end according to DIN EN 50347 and IEC 60072-1. The stub-shaft motors have a centering hole as per DIN 332-DS.

The QAN asynchronous motors with stub shaft are optionally available with plain shaft or with shaft with keyway:

- **Plain shaft end:** This shaft without keyway is the standard shaft for all asynchronous motors with spindle bearing.
- **Shaft end with key:** Asynchronous motors with keyway are **half-key balanced** and are supplied together with the machine key as per DIN 6885-1:
QAN 200: AS 10 x 8 x 70
QAN 260: AS 12 x 8 x 90
QAN 320: AS 16 x 10 x 90

The version with keyway is standard for all asynchronous motors with standard bearings.

Please note:

The asynchronous motors with keyway were supplied with **full-key balancing until mid-2014**. The current motors are **half-key balanced**. They are unambiguously identified by their ID number. It always ends with xxxxxx-xH (e.g. 374328-0H)

Precision balancing

QAN asynchronous motors from HEIDENHAIN can be balanced at any time.

Hollow-shaft motors

The QAN 200 UH and QAN 260 xH motors with hollow shaft are suited for direct mounting to mechanical spindles. The hollow shaft permits you to convey coolant to tools with inner cooling.

The coolant is introduced at the rear of the motor through a rotating union (e.g. from Deublin, order no.: 1109-020-188). The shaft end is designed for this.

Functional safety

No current QAN motor variants described here feature a fault exclusion against loosening of the mechanical connection between the encoder and the motor. You can have the safety parameters of the motors or the encoders installed in it (e.g. MTTF values, data on fault exclusion) upon request.

Installation elevation

The maximum altitude for installation of HEIDENHAIN motors is 1000 m above sea level. For installation altitudes above 1000 m, additional cooling measures are required.

Mechanical data

Design IM B35 (mounting via flange/base) according to IEC 60034-7

Mounting of the motor

The following screws are recommended for securing the motor:

<i>Fastening:</i>	<i>Flange</i>	<i>Base</i>
QAN 200	M12	M10
QAN 260	M16	M10
QAN 320	M16	M12

Flange: Dimensions as per DIN EN 50347 and IEC 60072-1

Protection as per EN 60529

Motor: IP54

Shaft end: IP43

Vibration severity

Grade SR (external precision balancing possible)
(IEC 60034-14)

Thermal specifications

Separate cooling via integrated fan

Temperature monitoring with KTY 84-130 thermistor in the stator winding

Thermal class F

Asynchronous motors with stub shaft	Rated power	Rated speed	Max. speed		Rated torque	Rated current	Recommended inverters ³⁾			Page
			Standard bearing	Spindle bearing			1-axis module	2-axis module	Compact inverter	
QAN 200M	5.5 kW	1500 rpm	9000 rpm	12000 rpm	35.0 Nm	18.0 A	UM 112 D	UM 122 D	Spindle output	26
QAN 200L	7.5 kW	1500 rpm	9000 rpm	12000 rpm	47.8 Nm	20.1 A	UM 112 D	UM 122 D	Spindle output	
QAN 200U	10.0 kW	1500 rpm	9000 rpm	12000 rpm	63.7 Nm	25.0 A	UM 112 D	UM 122 D	Spindle output ¹⁾	
QAN 260M	15.0 kW	1500 rpm	8000 rpm	10000 rpm	95.5 Nm	35.0 A	UM 113 D	–	Spindle output ²⁾	28
QAN 260L	20.0 kW	1500 rpm	8000 rpm	10000 rpm	127.3 Nm	46.0 A	UM 113 D	–	–	
QAN 260U	24.0 kW	1500 rpm	8000 rpm	10000 rpm	152.8 Nm	58.0 A	UM 114 D	–	–	
QAN 320M	32.0 kW	1500 rpm	8000 rpm	10000 rpm	203.7 Nm	77.5 A	UM 114 D	–	–	30
QAN 320L	40.0 kW	1500 rpm	8000 rpm	10000 rpm	254.6 Nm	99.0 A	UM 115 D	–	–	

Asynchronous motors with hollow shaft	Rated power	Rated speed	Max. speed		Rated torque	Rated current	Recommended inverters ³⁾			Page
			Standard bearing	Spindle bearing			1-axis module	2-axis module	Compact inverters	
QAN 200UH	10.0 kW	1500 rpm	–	12000 rpm 15000 rpm	63.7 Nm	25.0 A	UM 112 D	UM 122 D	Spindle output ¹⁾	32
QAN 260MH	15.0 kW	1500 rpm	–	12000 rpm	96.0 Nm	35.0 A	UM 113 D	–	Spindle output ²⁾	34
QAN 260LH	20.0 kW	1500 rpm	–	12000 rpm	128.0 Nm	46.0 A	UM 113 D	–	–	
QAN 260UH	22.0 kW	1500 rpm	–	10000 rpm 12000 rpm	140.0 Nm	54.0 A	UM 113 D ¹⁾ UM 114 D	–	–	

¹⁾ Only UE 24xB, UR 24x

²⁾ Only UR 24x

³⁾ The maximum acceleration of the motor might not be achievable with the recommended inverters. If necessary, a more powerful power module must be selected.

Asynchronous motors with stub shaft

Series QAN 200

Spindle motors with 2 pole pairs
 Rated power output 5.5 kW to 10 kW
 Choice of standard or spindle bearing

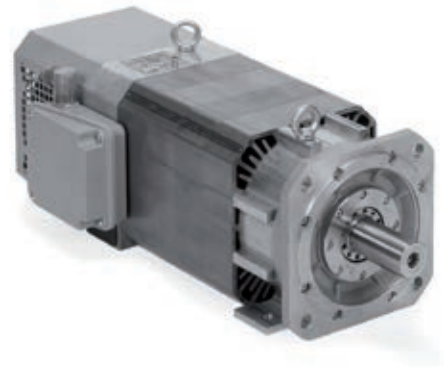

Motor	QAN 200M		QAN 200L		QAN 200U	
Rated voltage U_N	250 V		305 V		330 V	
Rated power output P_N	5.5 kW		7.5 kW		10.0 kW	
Rated speed n_N	1500 rpm					
Rated torque M_N (105 K)	35.0 Nm		47.8 Nm		63.7 Nm	
Rated current I_N (105 K)	18.0 A		20.1 A		25.0 A	
Efficiency	0.85					
Max. shaft speed n_{max} ¹⁾ Standard bearing Spindle bearing	9000 rpm 12000 rpm		9000 rpm 12000 rpm			
Max. current I_{max}	33 A		36 A		44 A	
Mass m	51 kg		68 kg		83 kg	
Rotor inertia J	245 kgcm ²		353 kgcm ²		405 kgcm ²	
Protection	IP 54					
Fan Rated voltage U_L Rated current I_L Frequency f_L	3AC 400 V 0.17 A/0.2 A 50 Hz/60 Hz					
ID Motor with standard bearing Motor with spindle bearing	Plain shaft 374328-03 374328-13	With keyway 374328-0H 374328-1H	Plain shaft 374329-03 374329-13	With keyway 374329-0H 374329-1H	Plain shaft 374330-03 374330-13	With keyway 374330-0H 374330-1H

¹⁾ The max. speed depends on the motor's application conditions, such as the shaft load
 (see the *Inverter Systems and Motors* Technical Manual)

Bold: Standard version

Rotatable connections

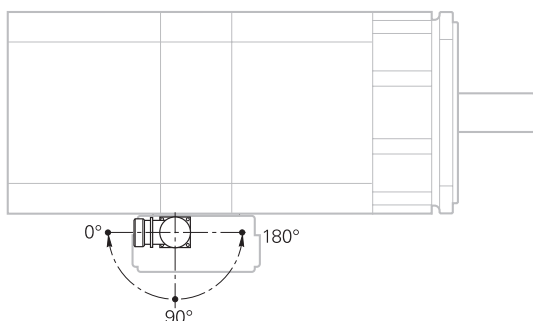

Encoder connector

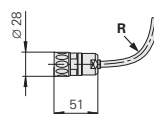

For **R** see page 41

QAN 200M

With standard bearing

With spindle bearing

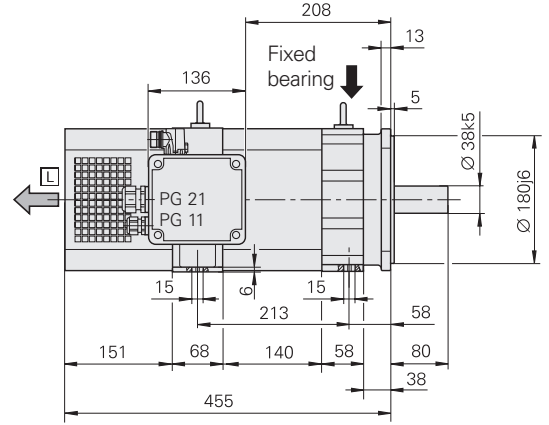
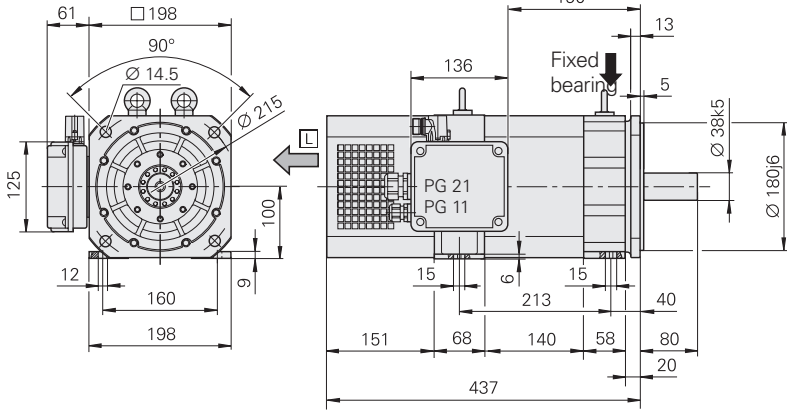

QAN 200L

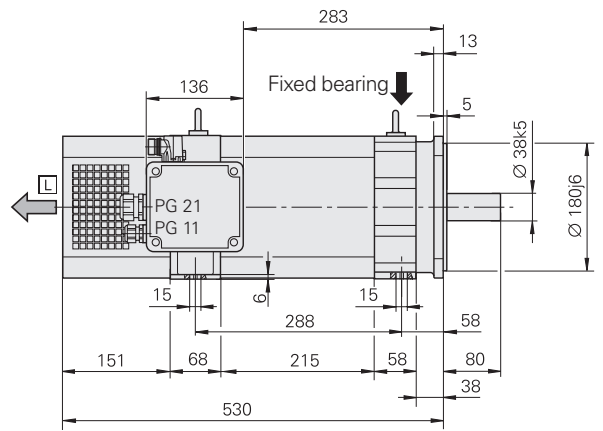
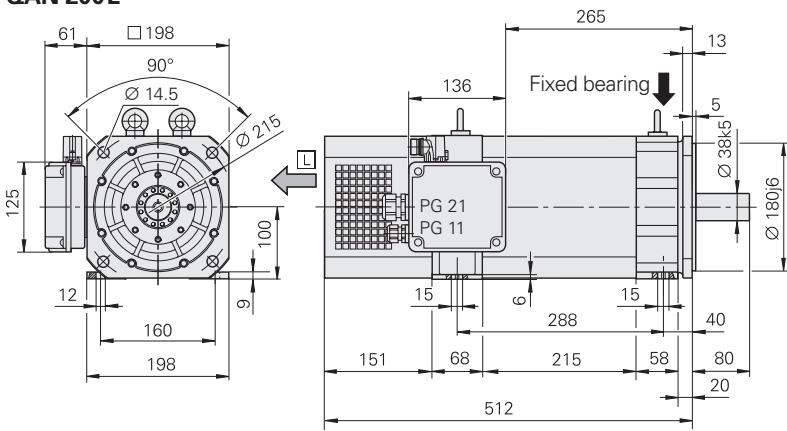

QAN 200U

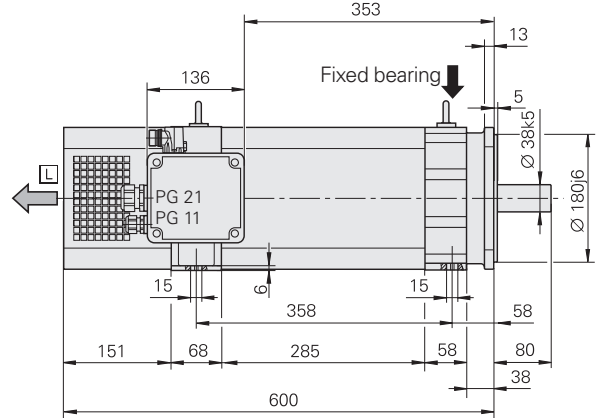
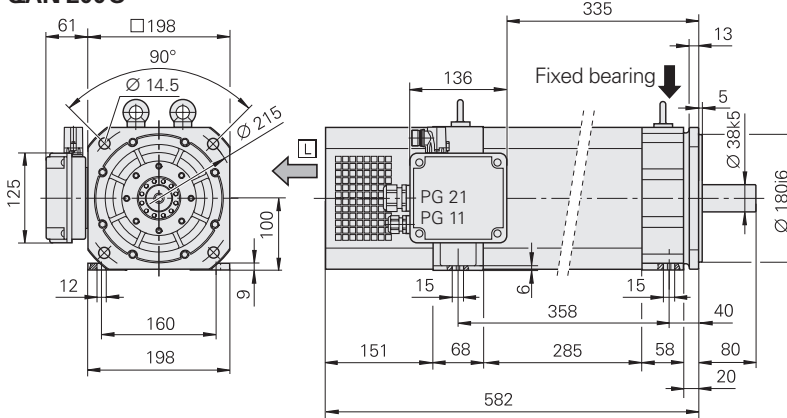

□ = Air flow
 PG 11: 5 mm to 10 mm
 PG 21: 13 mm to 18 mm

mm

 Tolerancing ISO 8015
 ISO 2768 - m H
 ≤ 6 mm: ±0.2 mm

Asynchronous motors with stub shaft

Series QAN 260

Spindle motors with 2 pole pairs
 Rated power output 12 kW to 24 kW
 Choice of standard or spindle bearing

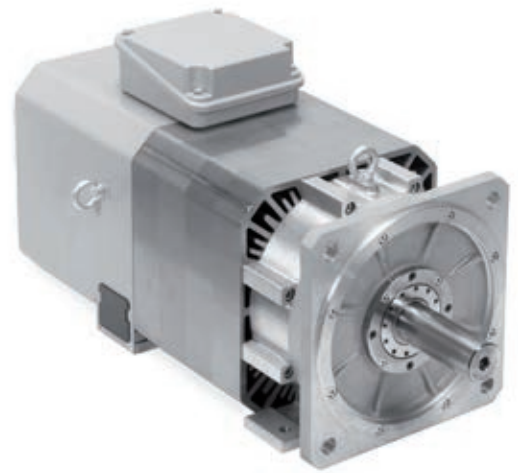

Motor	QAN 260 M		QAN 260 L		QAN 260 U	
Rated voltage U_N	348 V		331 V		318 V	
Rated power output P_N	15 kW		20 kW		24 kW	
Rated speed n_N	1500 rpm					
Rated torque M_N (105 K)	96.0 Nm		128.0 Nm		153.0 Nm	
Rated current I_N (105 K)	35.0 A		46.0 A		58.0 A	
Efficiency	0.85					
Max. shaft speed n_{max} ¹⁾ Standard bearing Spindle bearing*	8000 rpm 10000 rpm or 12000 rpm				8000 rpm 10000 rpm	
Max. current I_{max}	70 A		96 A		116 A	
Mass m	112 kg		135 kg		158 kg	
Rotor inertia J	700 kgcm ²		920 kgcm ²		1 100 kgcm ²	
Protection	IP 54					
Fan Rated voltage U_L Rated current I_L Frequency f_L	3AC 400 V 0.22 A/0.26 A 50 Hz/60 Hz					
ID Motor with standard bearing Motor with spindle bearing 10000 rpm 12000 rpm	Stub shaft 510019-63 510019-53 510019-73	With keyway 510019-4H 510019-5H —	Stub shaft 510020-43 510020-53 510020-73	With keyway 510020-4H 510020-5H —	Stub shaft 510021-43 510021-53 —	With keyway 510021-4H 510021-5H —

¹⁾ The max. speed depends on the motor's application conditions, such as the shaft load (see the *Inverter Systems and Motors* Technical Manual)

* Please select when ordering

Bold: Standard version

Rotatable connections

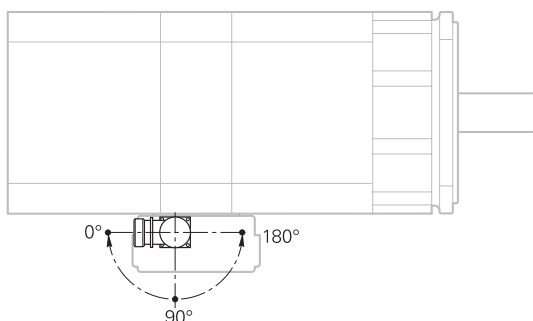

Encoder connector

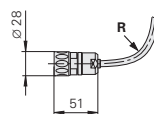

For **R** see page 41

QAN 260M

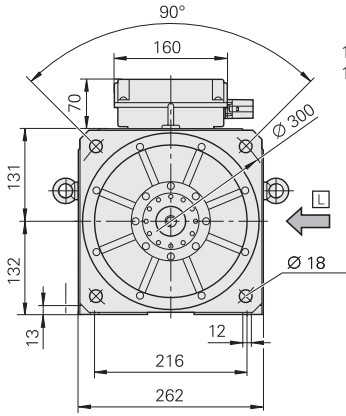

With standard bearing

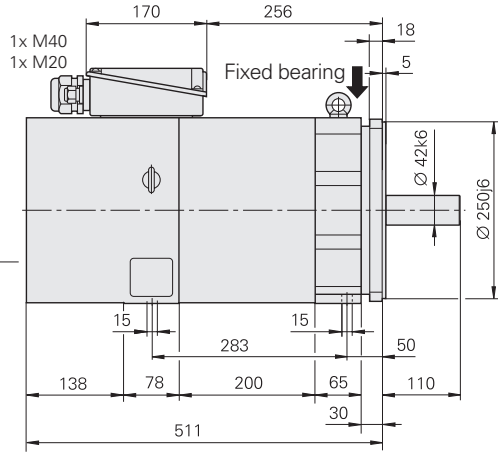

With spindle bearing

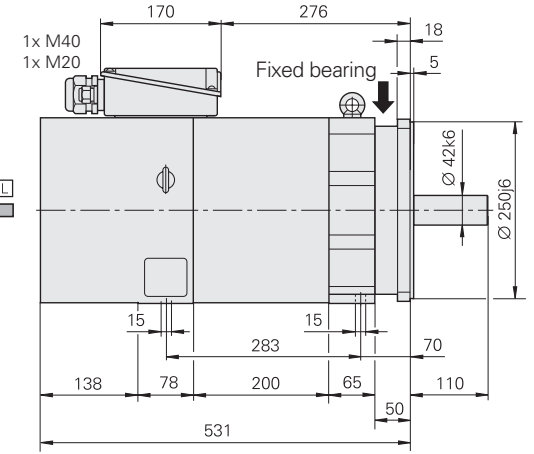

QAN 260L

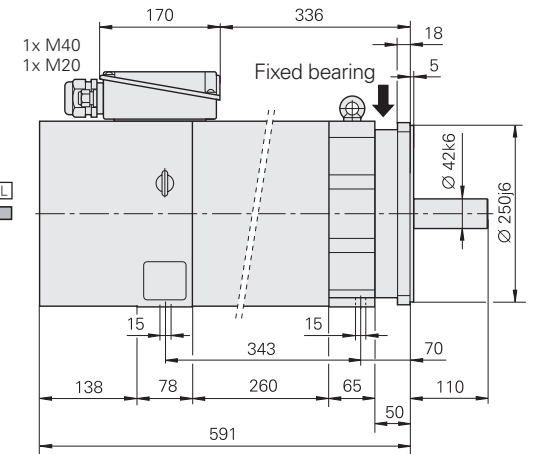
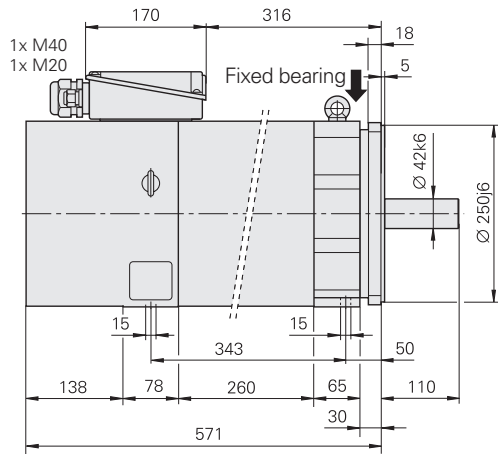
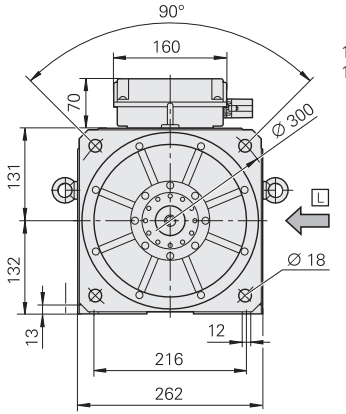

QAN 260U

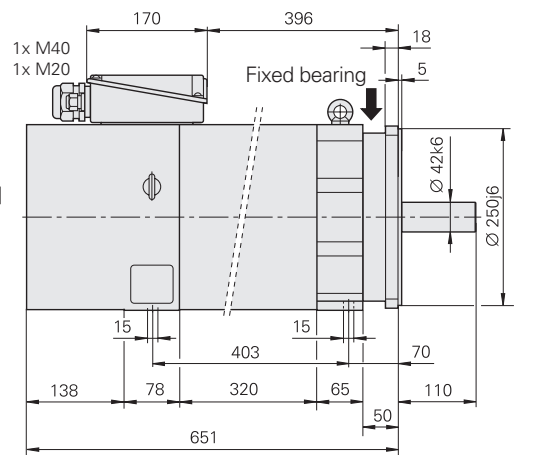
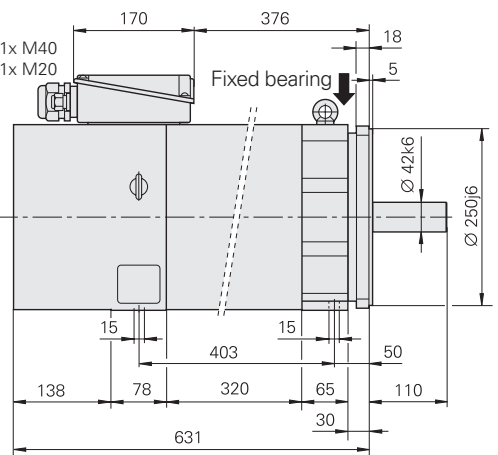
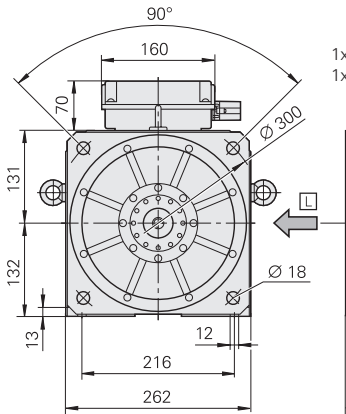

☐ = Air flow

QAN 260 M

M20: 6 mm to 12 mm
M40: 20 mm to 26 mm

QAN 260 L/U

M20: 6 mm to 12 mm
M40: 22 mm to 32 mm

mm



Tolerancing ISO 8015
ISO 2768 - m H
≤ 6 mm: ±0.2 mm

Asynchronous motors with stub shaft

Series QAN 320

Spindle motors with 2 pole pairs
 Rated power output 18 kW to 40 kW



Motor	QAN 320M	QAN 320L		
Rated voltage U_N	317 V	315 V		
Rated power output P_N	32 kW	40 kW		
Rated speed n_N	1500 rpm	1500 rpm		
Rated torque M_N (105 K)	203.7 Nm	254.6 Nm		
Rated current I_N (105 K)	77.5 A	99.0 A		
Efficiency	0.85	0.91		
Max. shaft speed n_{max} ¹⁾ Standard bearing Spindle bearing	8000 rpm 10000 rpm			
Max. current I_{max}	155 A	186 A		
Mass m	240 kg	280 kg		
Rotor inertia J	1870 kgcm ²	2300 kgcm ²		
Fan Rated voltage U_L Rated current I_L Frequency f_L	3AC 400 V 0.33 A/0.43 A 50 Hz/60 Hz			
ID Motor with standard bearing Motor with spindle bearing	Plain shaft 513302-43 513302-53	With keyway 513302-4H 513302-5H	Plain shaft 577484-43 577484-53	With keyway 577484-4H 577484-5H

¹⁾ The max. speed depends on the motor's application conditions, such as the shaft load
 (see the *Inverter Systems and Motors* Technical Manual)

Bold: Standard version

Rotatable connections

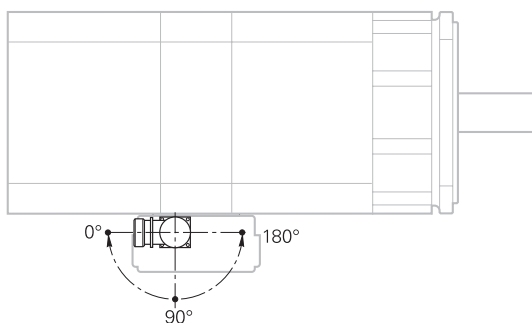

Encoder connector

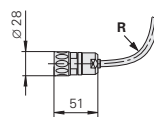

For **R** see page 41

QAN 320M

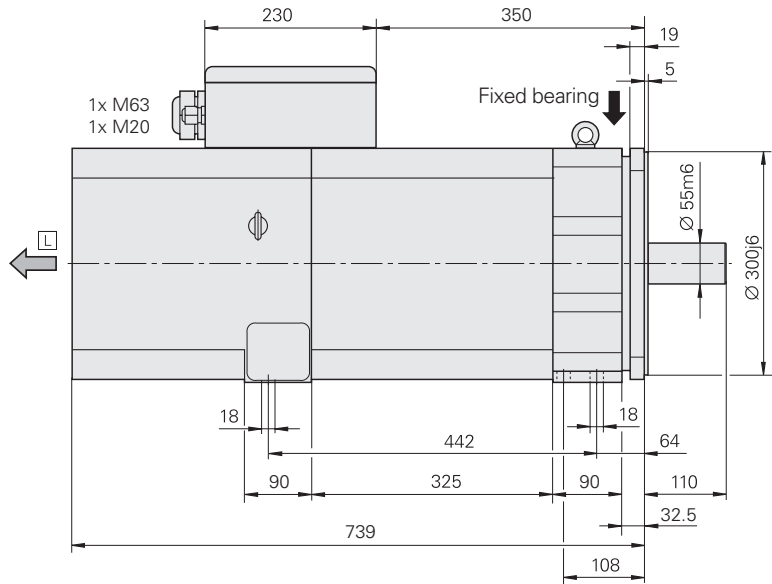
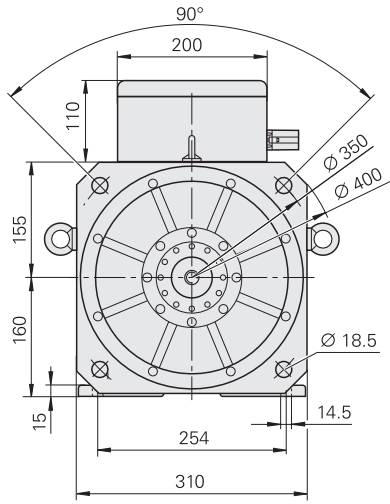

QAN 320L

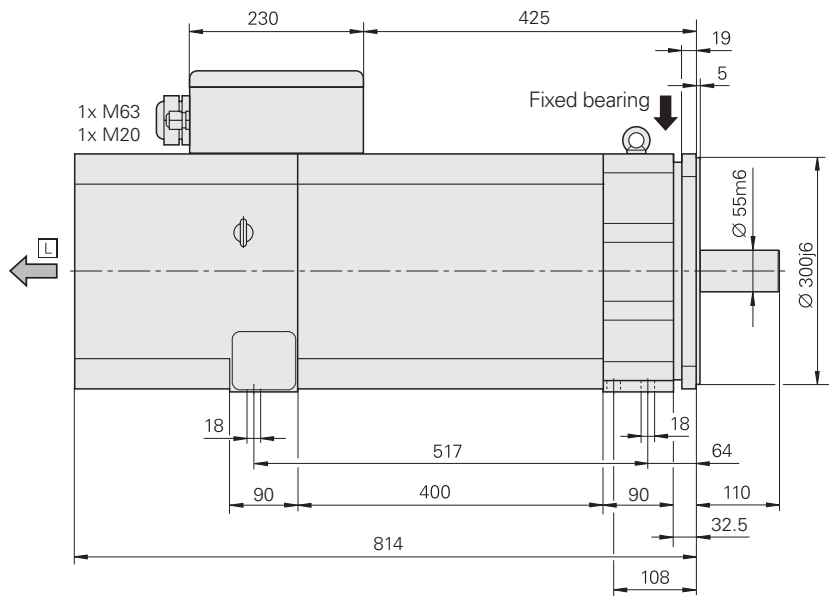
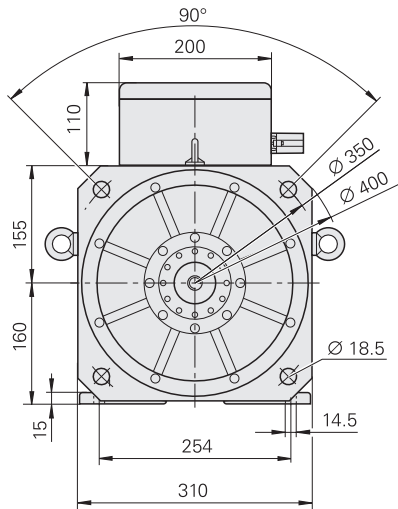

= Air flow
 M20: 6 mm to 12 mm
 M63: 34 mm to 45 mm

mm

 Tolerancing ISO 8015
 ISO 2768 - m H
 ≤ 6 mm: ±0.2 mm

Asynchronous motors with hollow shaft

QAN 200 UH

Hollow-shaft spindle motor with 2 pole pairs
 Rated power output to 10 kW
 With spindle bearing

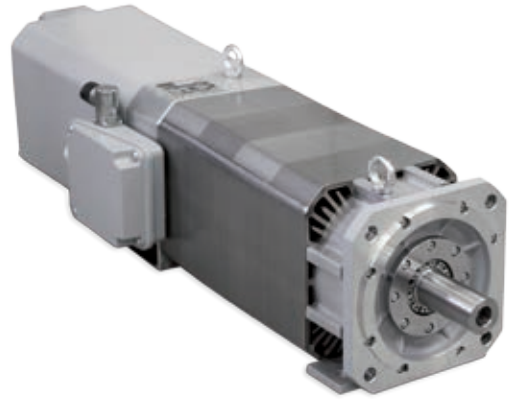

Motor	QAN 200 UH	
Rated voltage U_N	330 V	
Rated power output P_N	10.0 kW	
Rated speed n_N	1500 rpm	
Rated torque M_N (105 K)	63.7 Nm	
Rated current I_N (105 K)	25.0 A	
Efficiency	0.85	
Max. shaft speed $n_{max}^{1)}$ Spindle bearing	12000 rpm	15000 rpm
Max. current I_{max}	44 A	
Bore hole in shaft	Ø 9 mm	
Mass m	91 kg	
Rotor inertia J	405 kgcm ²	
Protection	IP 54	
Fan Rated voltage U_L Rated current I_L Frequency f_L	3AC 400 V 0.17 A/0.2 A 50 Hz/60 Hz	
ID Motor with spindle bearing	536257-18	536257-53

¹⁾ The max. speed depends on the motor's application conditions, such as the shaft load (see the *Inverter Systems and Motors* Technical Manual)

Rotatable connections

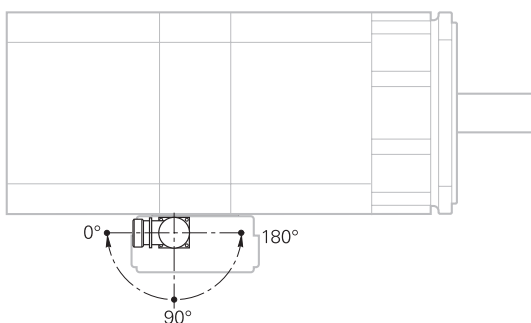

Encoder connector

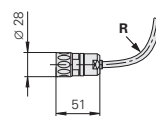

For **R** see page 41

QAN 200UH 12 000 rpm

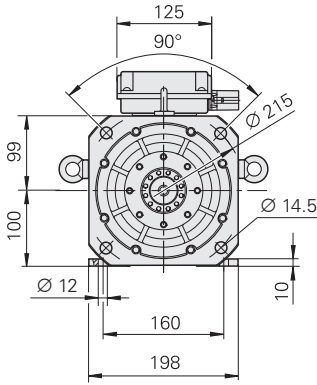

With spindle bearing

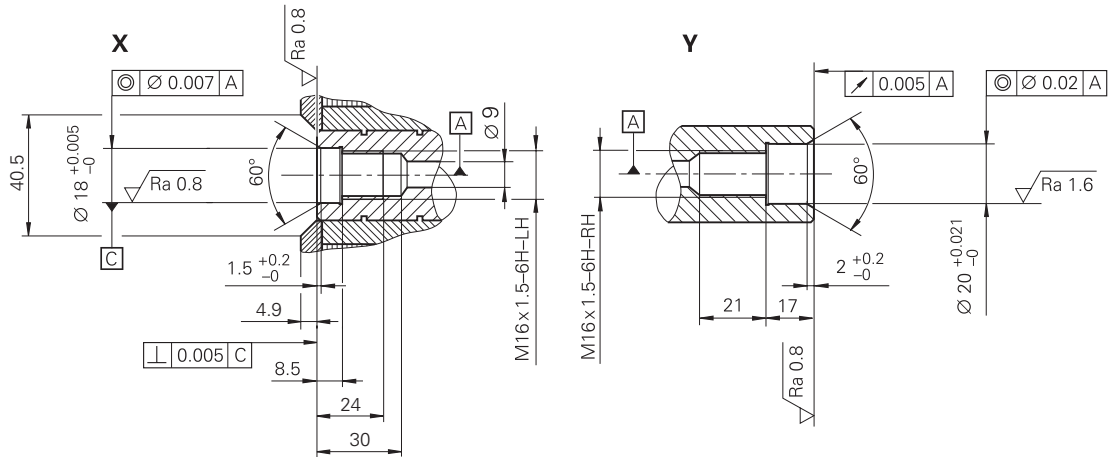
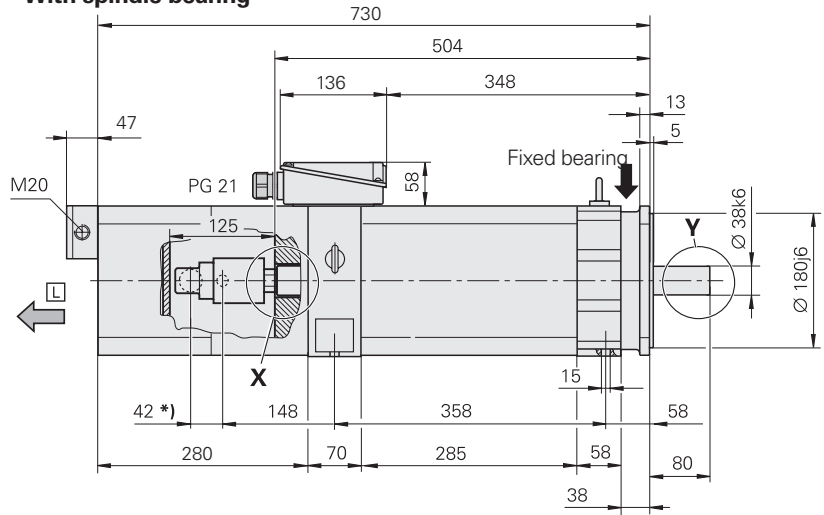

QAN 200UH 15 000 rpm

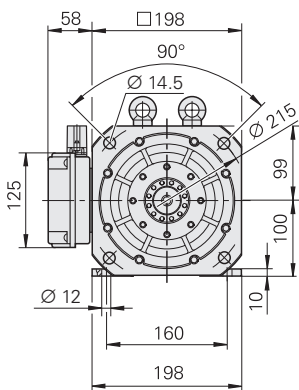

With spindle bearing

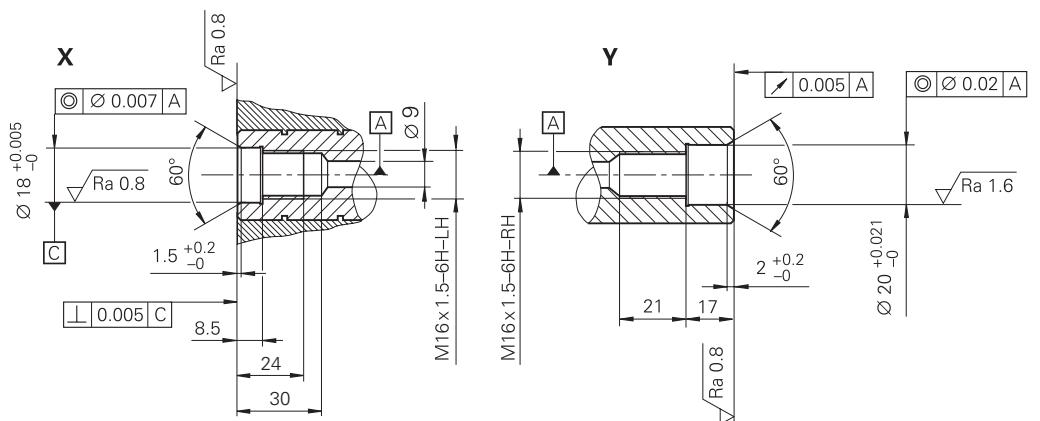
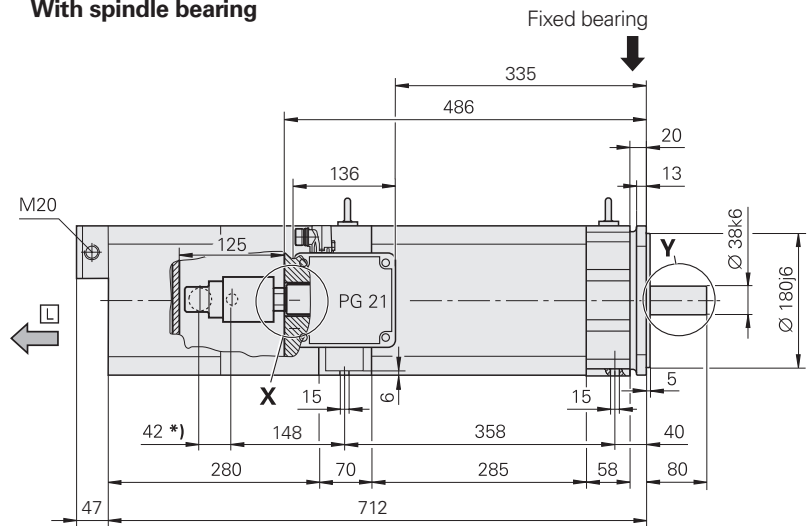

- ☐ = Air flow
- PG 21: 13 mm to 18 mm
- M20: 6 mm to 12 mm
- *) = Coolant connection on the right side, e.g. from Deublin 1109-020-188

mm

 Tolerancing ISO 8015
 ISO 2768 - m H
 ≤ 6 mm: ±0.2 mm

Asynchronous motors with hollow shaft

QAN 260xH series

Hollow-shaft spindle motor with 2 pole pairs
 Rated power output 15 kW to 22 kW
 With spindle bearing



Motor	QAN 260MH	QAN 260LH	QAN 260UH
Rated voltage U_N	348 V	331 V	318 V
Rated power output P_N	15 kW	20 kW	22 kW
Rated speed n_N	1500 rpm		
Rated torque M_N (105 K)	96.0 Nm	128.0 Nm	140.0 Nm
Rated current I_N (105 K)	35.0 A	46.0 A	54.0 A
Efficiency	0.85		
Max. shaft speed n_{max} ¹⁾ Spindle bearing*	12000 rpm		10000 rpm or 12000 rpm
Max. current I_{max}	70 A	96 A	116 A
Mass m	120 kg	143 kg	158 kg
Rotor inertia J	700 kgcm ²	920 kgcm ²	1100 kgcm ²
Protection	IP54		
Fan Rated voltage U_L Rated current I_L Frequency f_L	3AC 400 V 0.22 A/0.26 A 50 Hz/60 Hz		
ID Motor with spindle bearing			
10000 rpm	–	–	536259-53
12000 rpm	642855-73	631449-73	536259-73

¹⁾ The max. speed depends on the motor's application conditions, such as the shaft load
 (see the *Inverter Systems and Motors* Technical Manual)

* Please select when ordering

Rotatable connections

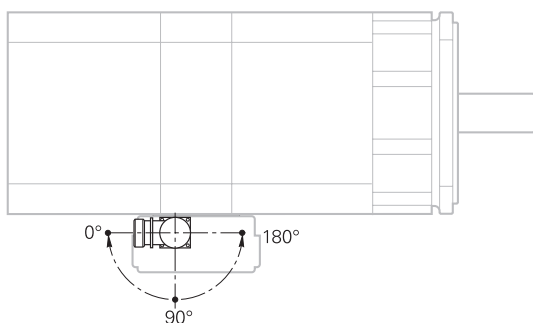

Encoder connector

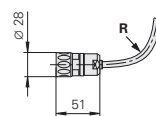

For **R** see page 41

QAN 260MH

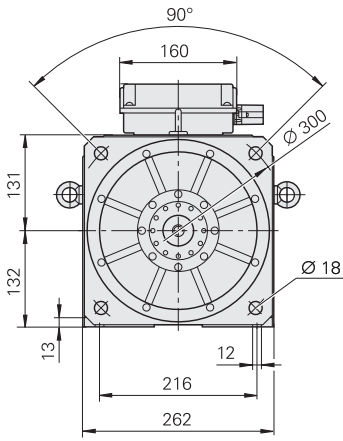

With spindle bearing

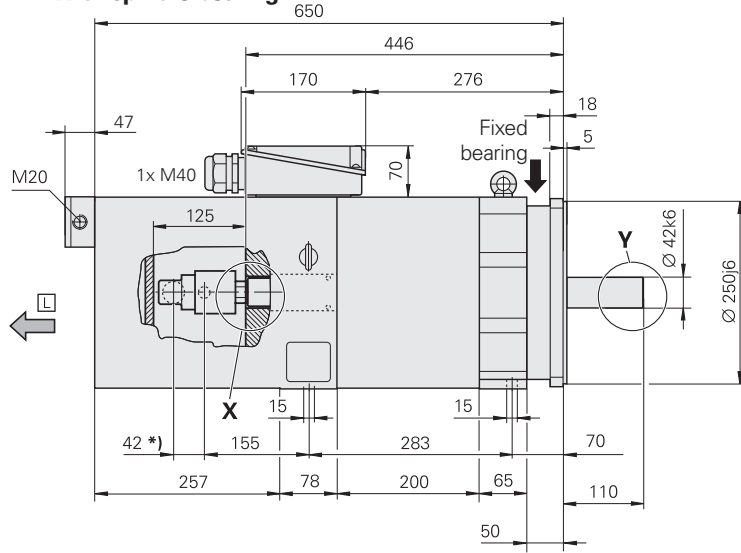

QAN 260LH

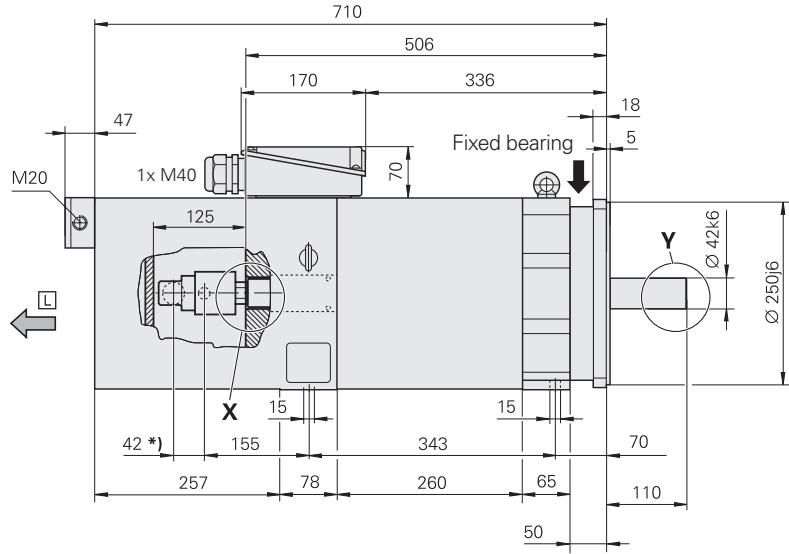
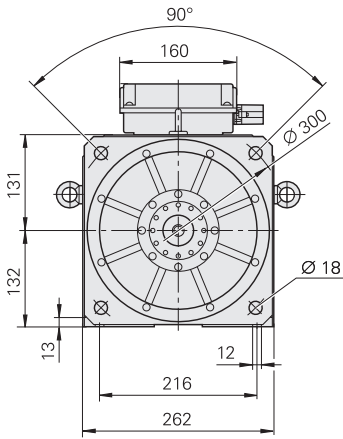

QAN 260UH

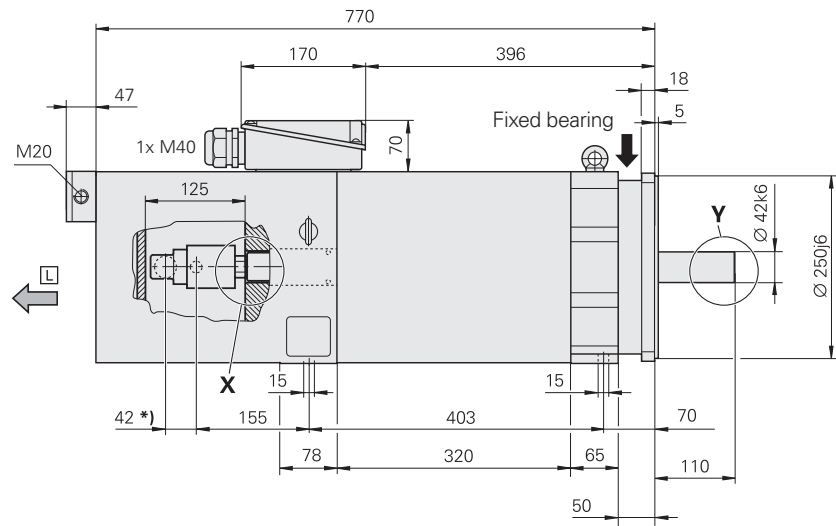
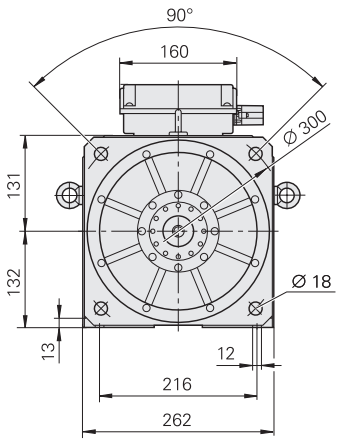

☐ = Air flow

QAN 260 MH

M20: 6 mm to 12 mm
M40: 20 mm to 26 mm

QAN 260 LH/UH

M20: 6 mm to 12 mm
M40: 22 mm to 32 mm

*) = Coolant connection on the right side, e.g. from Deublin 1109-020-188

mm



Tolerancing ISO 8015
ISO 2768 - m H
≤ 6 mm: ±0.2 mm

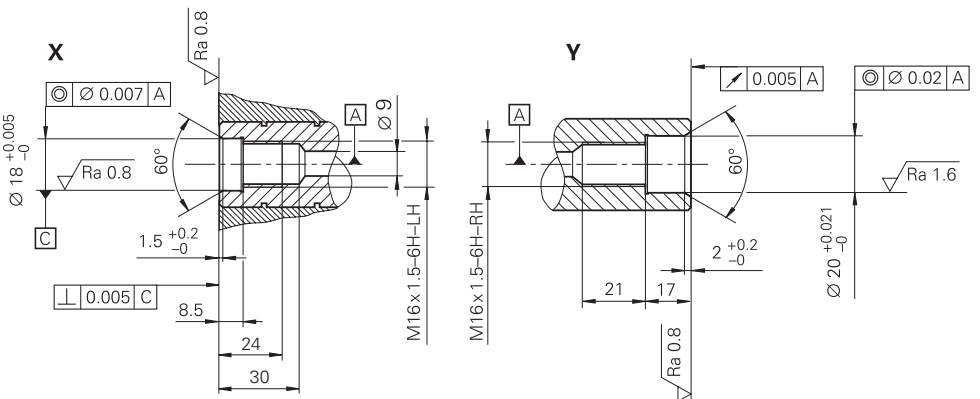

Asynchronous motors

Power and torque characteristics

QAN 200M

Mode of operation	Speed n	Power P	Torque M	Current I
S1	1 500 rpm	5.5 kW	35.0 Nm	18.0 A
	6 000 rpm	5.5 kW	8.8 Nm	–
	12 000 rpm	5.5 kW	4.4 Nm	–
S6-60%	1 500 rpm	7.0 kW	44.7 Nm	22.0 A
	6 000 rpm	7.0 kW	11.2 Nm	–
	12 000 rpm	7.0 kW	5.6 Nm	–
S6-40%	1 500 rpm	7.9 kW	50.4 Nm	24.0 A
	6 000 rpm	7.9 kW	12.6 Nm	–
	12 000 rpm	7.9 kW	6.3 Nm	–
S6-25%	1 500 rpm	9.5 kW	60.7 Nm	28.0 A
	6 000 rpm	9.5 kW	15.2 Nm	–
	12 000 rpm	9.5 kW	7.6 Nm	–

Power characteristic curve

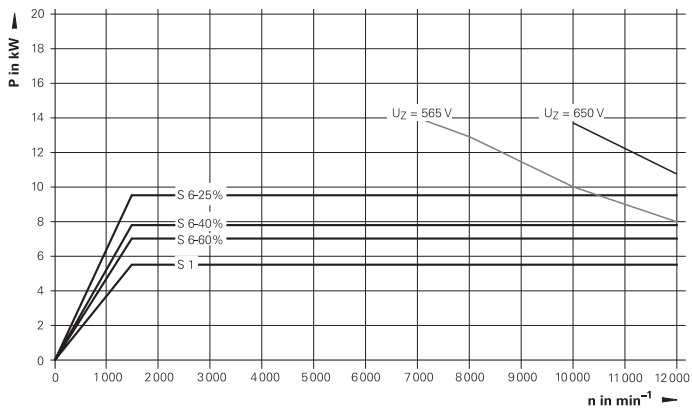

Torque characteristic curve

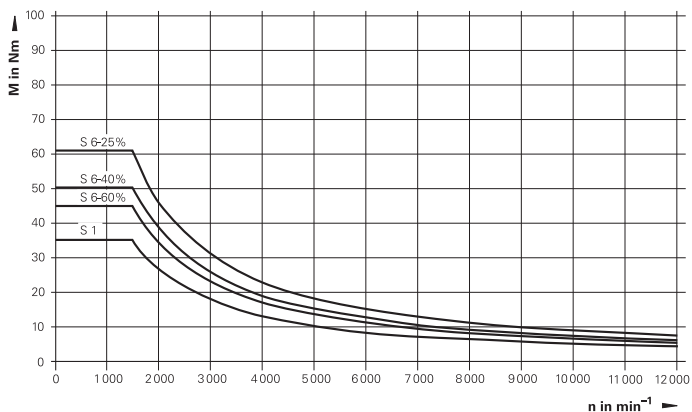

QAN 200L

Mode of operation	Speed n	Power P	Torque M	Current I
S1	1 500 rpm	7.5 kW	47.8 Nm	20.1 A
	6 000 rpm	7.5 kW	12.0 Nm	–
	12 000 rpm	7.5 kW	6.0 Nm	–
S6-60%	1 500 rpm	9.8 kW	62.6 Nm	24.0 A
	10 700 rpm	9.8 kW	9.5 Nm	–
	12 000 rpm	8.5 kW	6.8 Nm	–
S6-40%	1 500 rpm	11.5 kW	73.4 Nm	27.0 A
	9 000 rpm	11.5 kW	11.0 Nm	–
	12 000 rpm	8.5 kW	6.8 Nm	–
S6-25%	1 500 rpm	13.0 kW	83.0 Nm	31.0 A
	7 500 rpm	13.0 kW	16.6 Nm	–
	12 000 rpm	8.5 kW	6.8 Nm	–

Power characteristic curve

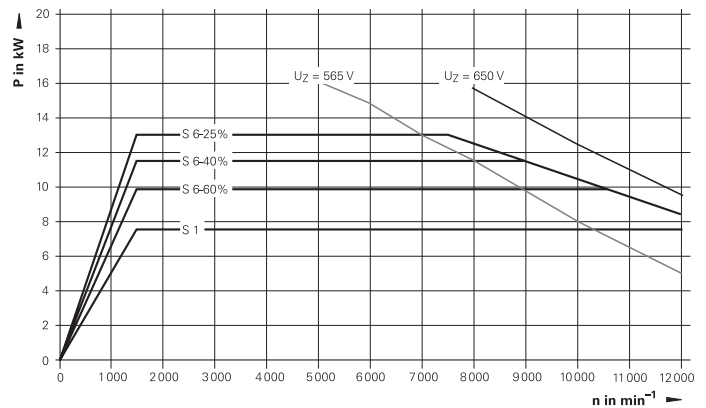

Torque characteristic curve

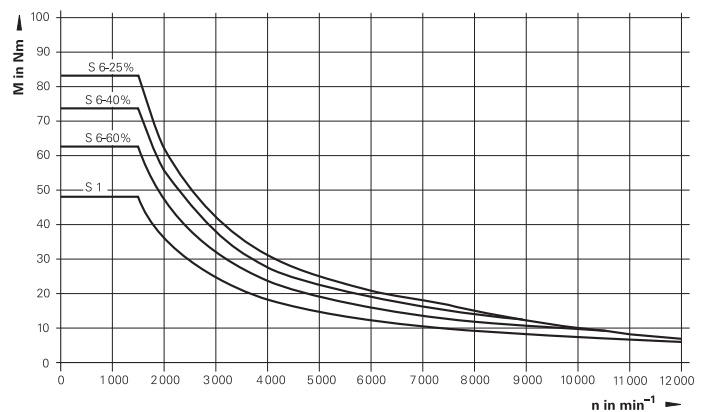

Note

- **S6 mode**

Cycle duration 10 minutes.

In the rest period the motor is idle.

QAN 200U

Mode of operation	Speed n	Power P	Torque M	Current I
S1	1 500 rpm	10.0 kW	63.7 Nm	25.0 A
	10 000 rpm	10.0 kW	9.5 Nm	–
	12 000 rpm	8.0 kW	6.4 Nm	–
S6-60%	1 500 rpm	12.5 kW	79.8 Nm	29.0 A
	10 000 rpm	12.5 kW	11.9 Nm	–
	12 000 rpm	10.0 kW	8.0 Nm	–
S6-40%	1 500 rpm	14.0 kW	89.4 Nm	32.0 A
	9 000 rpm	14.0 kW	19.1 Nm	–
	12 000 rpm	11.0 kW	8.8 Nm	–
S6-25%	1 500 rpm	17.0 kW	108.6 Nm	37.0 A
	7 500 rpm	17.0 kW	21.7 Nm	–
	12 000 rpm	12.0 kW	9.5 Nm	–

Power characteristic curve

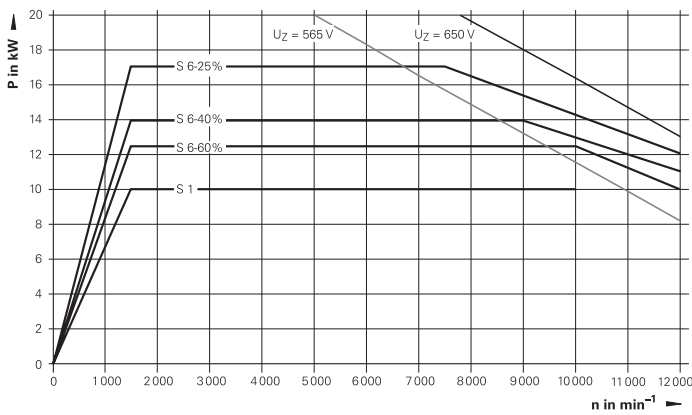

Torque characteristic curve

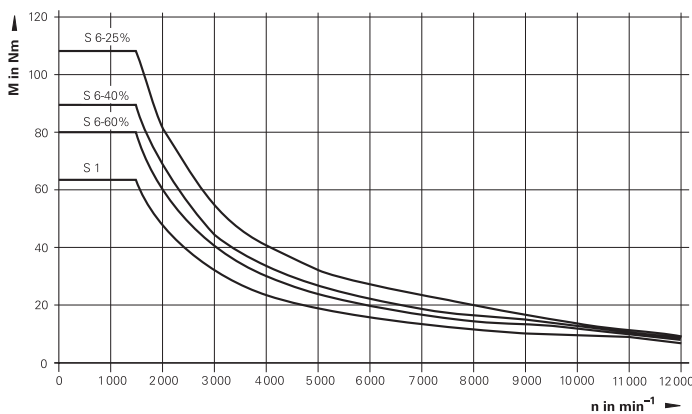

QAN 200UH

Mode of operation	Speed n	Power P	Torque M	Current I
S1	1 500 rpm	10.0 kW	63.7 Nm	25.0 A
	10 000 rpm	10.0 kW	9.5 Nm	–
	12 000 rpm	8.0 kW	6.4 Nm	–
	15 000 rpm	4.0 kW	2.5 Nm	–
S6-60%	1 500 rpm	12.5 kW	79.8 Nm	29.0 A
	10 000 rpm	12.5 kW	11.9 Nm	–
	12 000 rpm	10.0 kW	8.0 Nm	–
	15 000 rpm	5.0 kW	3.2 Nm	–
S6-40%	1 500 rpm	14.0 kW	89.4 Nm	32.0 A
	9 000 rpm	14.0 kW	19.1 Nm	–
	12 000 rpm	11.0 kW	8.8 Nm	–
	15 000 rpm	6.0 kW	3.8 Nm	–
S6-25%	1 500 rpm	17.0 kW	108.6 Nm	37.0 A
	7 500 rpm	17.0 kW	21.7 Nm	–
	12 000 rpm	12.0 kW	9.5 Nm	–
	15 000 rpm	7.0 kW	4.5 Nm	–

Power characteristic curve

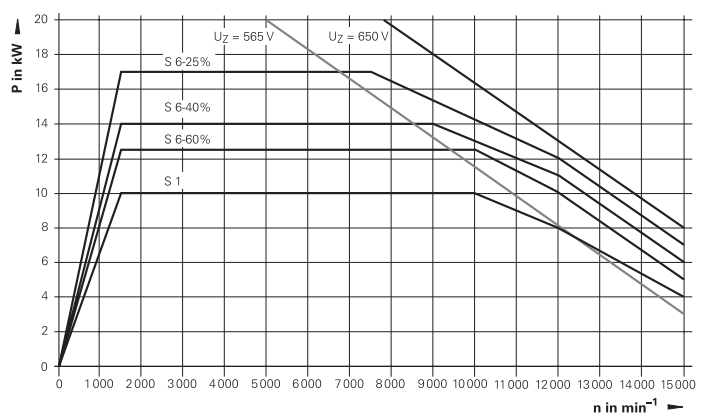

Torque characteristic curve

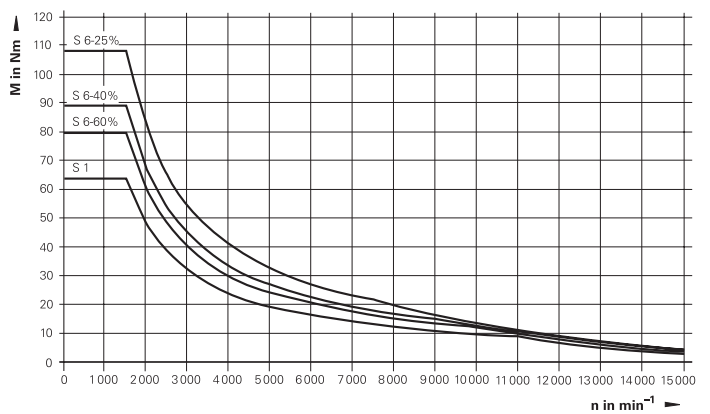

QAN 260M, QAN 260MH

Mode of operation	Speed n	Power P	Torque M	Current I
S1	1 500 rpm	15.0 kW	95.5 Nm	35.0 A
	6 500 rpm	15.0 kW	22.0 Nm	–
	10 000 rpm	10.0 kW	9.5 Nm	–
	12 000 rpm	4.0 kW	3.2 Nm	–
S6-60%	1 500 rpm	20.0 kW	127.3 Nm	43.3 A
	5 000 rpm	20.0 kW	38.2 Nm	–
	9 000 rpm	13.5 kW	14.3 Nm	–
S6-40%	1 500 rpm	25.0 kW	159.2 Nm	52.3 A
	4 500 rpm	25.0 kW	53.1 Nm	–
	8 000 rpm	16.8 kW	20.1 Nm	–
S6-25%	1 500 rpm	32.0 kW	203.7 Nm	65.0 A
	4 000 rpm	32.0 kW	76.4 Nm	–
	6 000 rpm	23.7 kW	37.7 Nm	–

Power characteristic curve

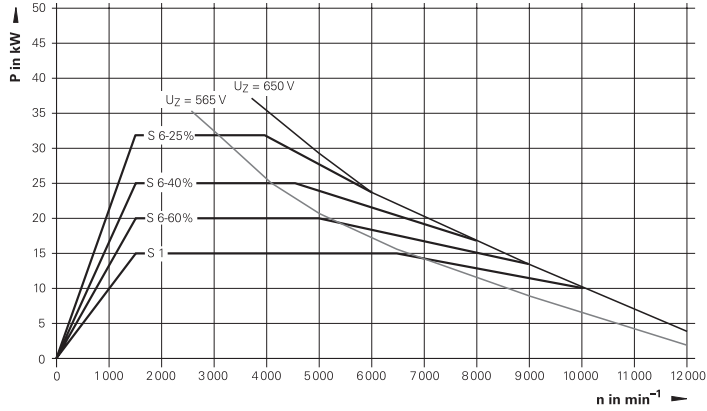

Torque characteristic curve

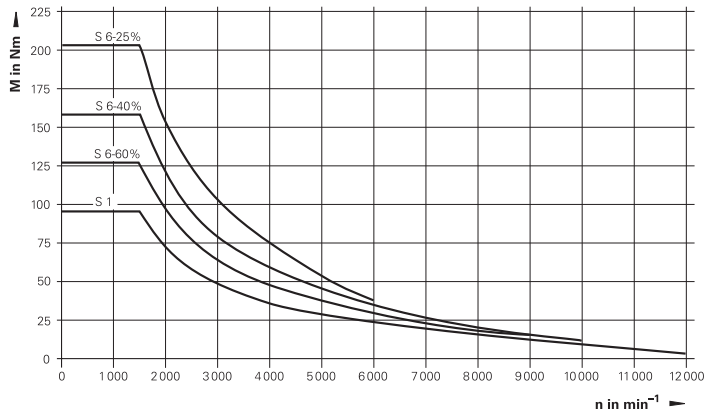

QAN 260L, QAN 260LH

Mode of operation	Speed n	Power P	Torque M	Current I
S1	1 500 rpm	20.0 kW	127.3 Nm	46.0 A
	6 500 rpm	20.0 kW	29.4 Nm	–
	10 000 rpm	13.0 kW	12.4 Nm	–
	12 000 rpm	8.0 kW	6.4 Nm	–
S6-60%	1 500 rpm	25.0 kW	159.2 Nm	56.0 A
	6 000 rpm	25.0 kW	39.4 Nm	–
	10 000 rpm	16.0 kW	15.3 Nm	–
	12 000 rpm	8.0 kW	6.4 Nm	–
S6-40%	1 500 rpm	30.0 kW	191.0 Nm	65.0 A
	5 500 rpm	30.0 kW	52.1 Nm	–
	10 000 rpm	17.5 kW	16.7 Nm	–
S6-25%	1 500 rpm	37.0 kW	235.5 Nm	79.0 A
	5 000 rpm	37.0 kW	70.7 Nm	–
	8 000 rpm	24.0 kW	28.6 Nm	–

Power characteristic curve

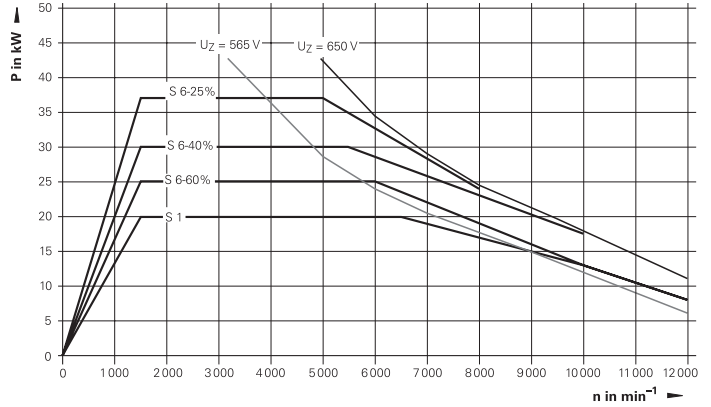

Torque characteristic curve

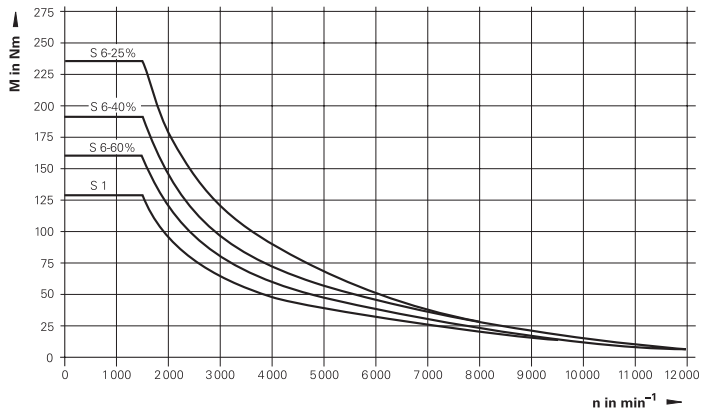

QAN 260U

Mode of operation	Speed n	Power P	Torque M	Current I
S1	1 500 rpm	24.0 kW	152.8 Nm	58.0 A
	7 400 rpm	24.0 kW	31.0 Nm	–
	10 000 rpm	18.0 kW	17.2 Nm	–
S6-60%	1 500 rpm	30.0 kW	191.0 Nm	67.2 A
	7 000 rpm	30.0 kW	40.9 Nm	–
	10 000 rpm	22.5 kW	21.5 Nm	–
S6-40%	1 500 rpm	38.0 kW	241.9 Nm	81.8 A
	5 500 rpm	38.0 kW	66.0 Nm	–
	10 000 rpm	26.0 kW	24.8 Nm	–
S6-25%	1 500 rpm	48.0 kW	305.6 Nm	100.6 A
	4 500 rpm	48.0 kW	101.9 Nm	–
	7 000 rpm	41.0 kW	55.9 Nm	–

Power characteristic curve

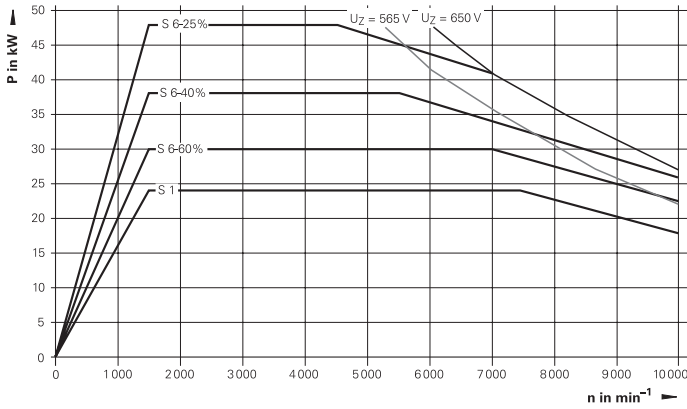

Torque characteristic curve

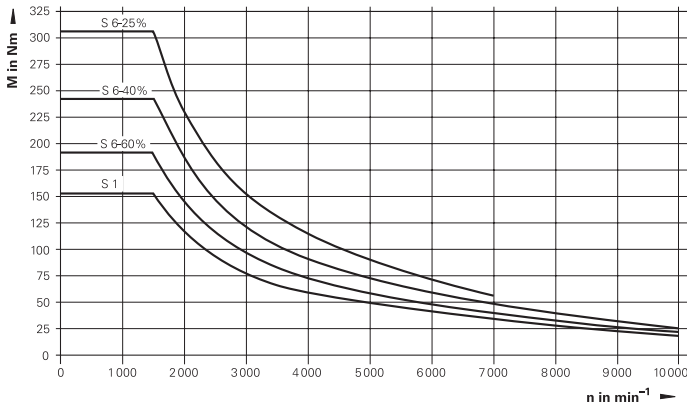

QAN 260UH

Mode of operation	Speed n	Power P	Torque M	Current I
S1	1 500 rpm	22.0 kW	140.1 Nm	54.0 A
	7 400 rpm	22.0 kW	28.4 Nm	–
	10 000 rpm	16.0 kW	15.3 Nm	–
S6-60%	1 500 rpm	30.0 kW	191.0 Nm	67.0 A
	6 500 rpm	30.0 kW	44.1 Nm	–
	10 000 rpm	20.0 kW	19.5 Nm	–
S6-40%	1 500 rpm	35.0 kW	222.8 Nm	77.0 A
	6 500 rpm	35.0 kW	66.8 Nm	–
	10 000 rpm	24.0 kW	22.9 Nm	–
S6-25%	1 500 rpm	46.0 kW	286.5 Nm	97.0 A
	5 000 rpm	46.0 kW	85.9 Nm	–
	10 000 rpm	27.0 kW	25.8 Nm	–

Power characteristic curve

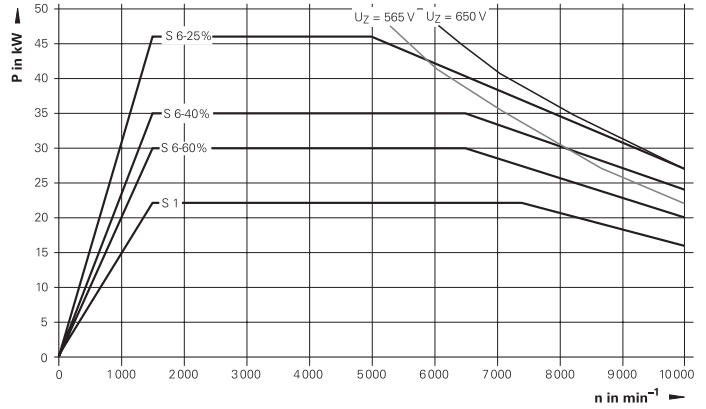

Torque characteristic curve

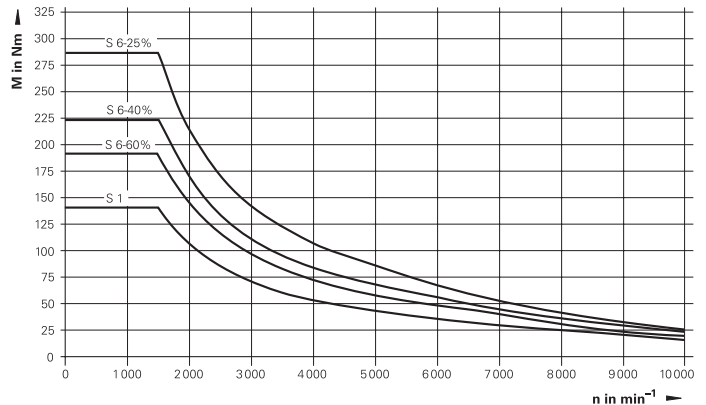

QAN 320M

Mode of operation	Speed n	Power P	Torque M	Current I
S1	1 500 rpm	32.0 kW	203.7 Nm	77.5 A
	5 500 rpm	32.0 kW	55.0 Nm	–
	10 000 rpm	19.5 kW	18.6 Nm	–
S6-60%	1 500 rpm	43.0 kW	273.7 Nm	98.0 A
	5 500 rpm	43.0 kW	71.5 Nm	–
	10 000 rpm	25.0 kW	23.9 Nm	–
S6-40%	1 500 rpm	53.0 kW	337.4 Nm	118.0 A
	5 500 rpm	53.0 kW	86.2 Nm	–
	6 000 rpm	48.0 kW	76.4 Nm	–

Power characteristic curve

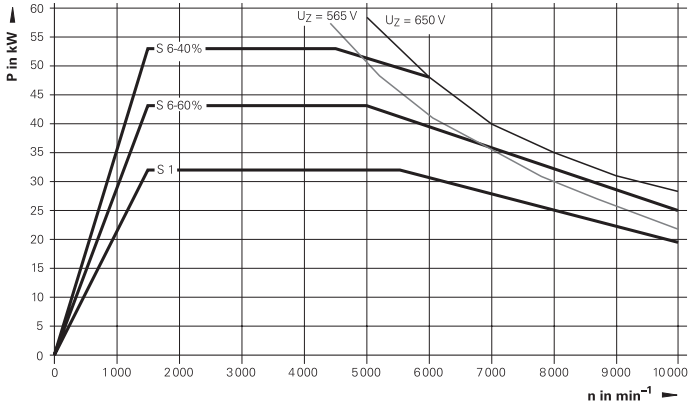

Torque characteristic curve

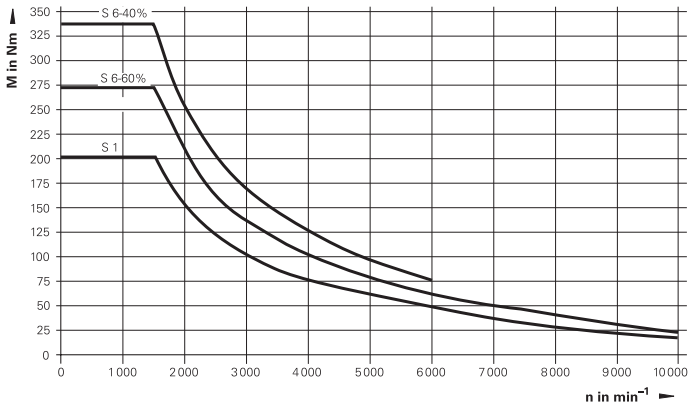

QAN 320L

Mode of operation	Speed n	Power P	Torque M	Current I
S1	1 500 rpm	40.0 kW	254.6 Nm	99.0 A
	5 000 rpm	40.0 kW	77.9 Nm	–
	10 000 rpm	21.0 kW	21.0 Nm	–
S6-60%	1 500 rpm	53.0 kW	337.4 Nm	123.0 A
	4 500 rpm	53.0 kW	112.5 Nm	–
	10 000 rpm	24.0 kW	22.9 Nm	–
S6-40%	1 500 rpm	66.0 kW	420.2 Nm	148.0 A
	4 500 rpm	66.0 kW	140.1 Nm	–
	10 000 rpm	28.0 kW	26.7 Nm	–

Power characteristic curve

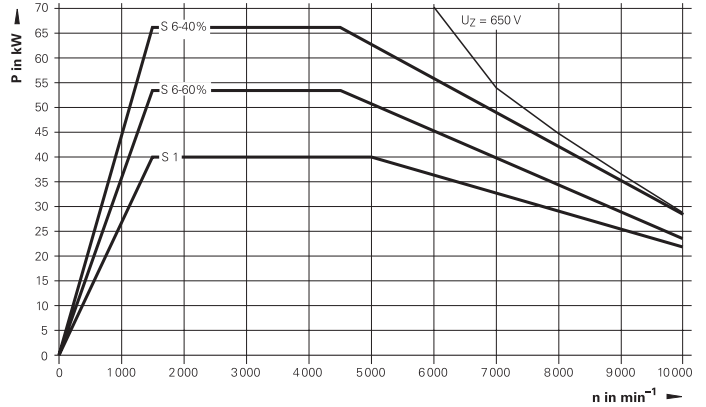

Torque characteristic curve

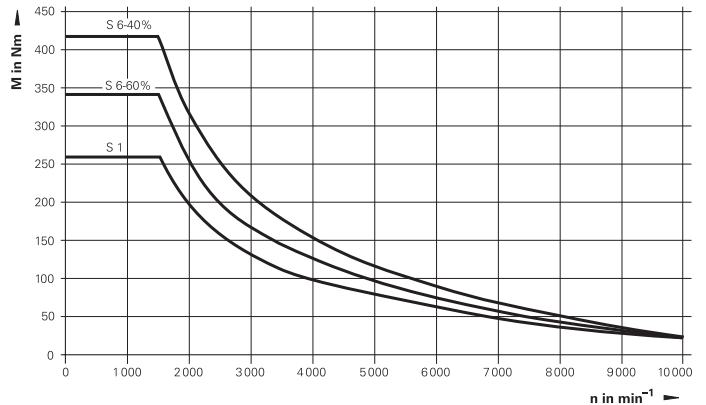

Asynchronous motors

Cables

Power cables

Current load at ambient temperature up to 40 °C

	Cable only ID	Bend radius R for frequent flexing	Cable type	Diameter
Current load up to 26 A (installation type B2)				
QAN 200M QAN 200L QAN 200U QAN 200UH	818787-xx <i>1213900-xx</i>	≥ 69 mm ≥ 109 mm	PUR [4 x 4 mm ²]	13.8 mm <i>14.5 mm</i>
Current load up to 45.2 A (installation type B2)				
QAN 260M QAN 260MH	818782-xx <i>1213901-xx</i>	≥ 102 mm ≥ 157 mm	PUR [4 x 10 mm ²]	20.3 mm <i>20.9 mm</i>
Current load up to 59.9 A (installation type B2)				
QAN 260L QAN 260LH QAN 260U QAN 260UH	818510-xx <i>1213902-xx</i>	≥ 133 mm ≥ 207 mm	PUR [4 x 16 mm ²]	26.5 mm <i>27.5 mm</i>
Current load up to 93.8 A (installation type B2)				
QAN 320M	818781-xx <i>1213903-xx</i>	≥ 173 mm ≥ 258 mm	PUR [4 x 35 mm ²]	34.5 mm <i>34.3 mm</i>
Current load up to 117.5 A (installation types C and E)				
QAN 320L	818781-xx <i>1213903-xx</i>	≥ 173 mm ≥ 258 mm	PUR [4 x 35 mm ²]	34.5 mm <i>34.3 mm</i>

Italics: Shielded power cable

Encoder cable

	Cable length	Cable complete with connectors ID	Line drop compensator ID	Extension cable ID	Bend radius R for frequent flexing
All QANs	< 30 m	289440-xx	–	336847-xx (as required)	≥ 100 mm
	> 30 m	289440-xx	370226-01	336847-xx	

Cables for fans

	Cable only ID	Bend radius R for frequent flexing	Cable type	Diameter
All QANs	818789-xx <i>1213898-xx</i>	≥ 50 mm ≥ 82 mm	PUR [4 x 0.75 mm ²]	9.9 mm <i>10.9 mm</i>

Italics: Shielded power cable

Accessories

Toroidal cores

Large line lengths can result in voltage peaks that may damage the motor. For this reason, toroidal cores need to be used in motor lines with lengths greater than 15 m. One toroidal core is required per phase. The toroidal cores must be located close to the inverter (max. 2 m).

Toroidal core

For motor line > 15 m
ID 827054-01

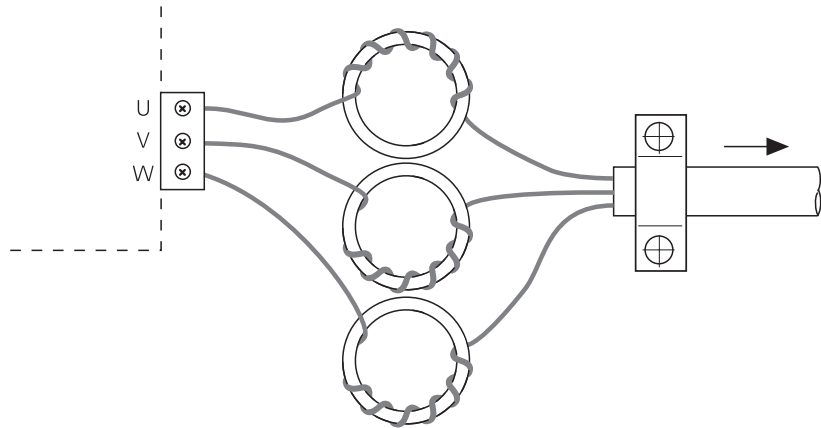

Dimensions

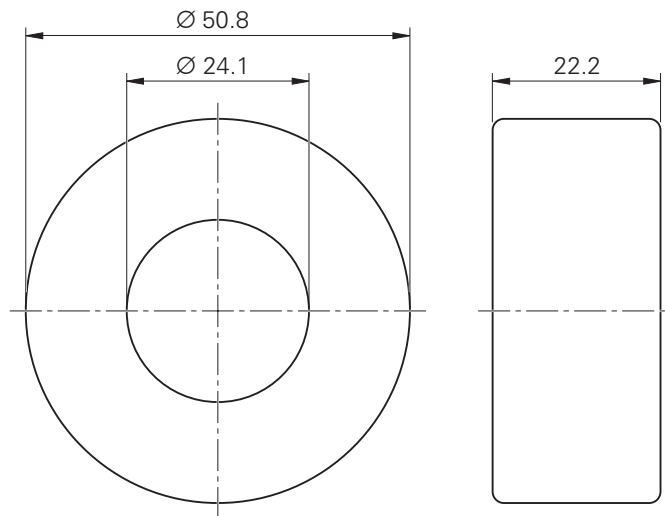

mm
Tolerancing ISO 8015
ISO 2768 - m H
 ≤ 6 mm: ± 0.2 mm

Torque motors for direct drives

Besides synchronous and asynchronous motors, HEIDENHAIN offers a comprehensive assortment of standard torque motors. With more than 100 models, almost any requirement can be met.

Overview of the most important features:

- Outside diameter up to 1290 mm
- Large hollow shaft up to 1070 mm
- Maximum rated speed up to 5170 rpm
- Peak torque up to 31 200 Nm
- Very high continuous torque
- Field weakening conformant
- With or without liquid-cooled cage
- Conceived for highly demanding applications

Direct coupling of the load with the rotor eliminates the need for any mechanical transfer elements such as transmissions, toothed belts or worm gears. The maintenance-free direct drives therefore offer excellent dynamic performance while guaranteeing a long service life.

The torque motors have the advantage of a patented, cogging-free design. This design provides outstanding peak power density in the magnet gap as well as unique thermal efficiency, which is a considerable advantage for precision, which reacts negatively to thermal drift.

Further advantages of torque motors are:

- Patented and proven technology
- Excellent performance
- High quality
- Simple integration
- Wide product range

The torque motors are developed and produced by ETEL—a company of the HEIDENHAIN Group.



Torque motors for direct drives

HEIDENHAIN

DR. JOHANNES HEIDENHAIN GmbH

Dr.-Johannes-Heidenhain-Straße 5

83301 Traunreut, Germany

☎ +49 8669 31-0

FAX +49 8669 32-5061

E-mail: info@heidenhain.de

www.heidenhain.de

Vollständige und weitere Adressen siehe www.heidenhain.de
For complete and further addresses see www.heidenhain.de

DE	HEIDENHAIN Vertrieb Deutschland 83301 Traunreut, Deutschland ☎ 08669 31-3132 FAX 08669 32-3132 E-Mail: hd@heidenhain.de	ES	FARRESA ELECTRONICA S.A. 08028 Barcelona, Spain www.farresa.es	PL	APS 02-384 Warszawa, Poland www.heidenhain.pl
	HEIDENHAIN Technisches Büro Nord 12681 Berlin, Deutschland ☎ 030 54705-240	FI	HEIDENHAIN Scandinavia AB 01740 Vantaa, Finland www.heidenhain.fi	PT	FARRESA ELECTRÓNICA, LDA. 4470 - 177 Maia, Portugal www.farresa.pt
	HEIDENHAIN Technisches Büro Mitte 07751 Jena, Deutschland ☎ 03641 4728-250	FR	HEIDENHAIN FRANCE sarl 92310 Sèvres, France www.heidenhain.fr	RO	HEIDENHAIN Reprezentantă Romania Braşov, 500407, Romania www.heidenhain.ro
	HEIDENHAIN Technisches Büro West 44379 Dortmund, Deutschland ☎ 0231 618083-0	GB	HEIDENHAIN (G.B.) Limited Burgess Hill RH15 9RD, United Kingdom www.heidenhain.co.uk	RS	Serbia → BG
	HEIDENHAIN Technisches Büro Südwest 70771 Leinfelden-Echterdingen, Deutschland ☎ 0711 993395-0	GR	MB Milionis Vassilis 17341 Athens, Greece www.heidenhain.gr	RU	OOO HEIDENHAIN 115172 Moscow, Russia www.heidenhain.ru
	HEIDENHAIN Technisches Büro Südost 83301 Traunreut, Deutschland ☎ 08669 31-1345	HK	HEIDENHAIN LTD Kowloon, Hong Kong E-mail: sales@heidenhain.com.hk	SE	HEIDENHAIN Scandinavia AB 12739 Skärholmen, Sweden www.heidenhain.se
		HR	Croatia → SL	SG	HEIDENHAIN PACIFIC PTE LTD Singapore 408593 www.heidenhain.com.sg
AR	NAKASE SRL. B1653AOX Villa Ballester, Argentina www.heidenhain.com.ar	HU	HEIDENHAIN Kereskedelmi Képviselet 1239 Budapest, Hungary www.heidenhain.hu	SK	KOPRETINA TN s.r.o. 91101 Trenčín, Slovakia www.kopretina.sk
AT	HEIDENHAIN Techn. Büro Österreich 83301 Traunreut, Germany www.heidenhain.de	ID	PT Servitama Era Toolsindo Jakarta 13930, Indonesia E-mail: ptset@group.gts.co.id	SL	NAVO d.o.o. 2000 Maribor, Slovenia www.heidenhain.si
AU	FCR MOTION TECHNOLOGY PTY LTD 3026 Victoria, Australia E-mail: sales@fcrmotion.com	IL	NEUMO VARGUS MARKETING LTD. Tel Aviv 61570, Israel E-mail: neumo@neumo-vargus.co.il	TH	HEIDENHAIN (THAILAND) LTD Bangkok 10250, Thailand www.heidenhain.co.th
BE	HEIDENHAIN NV/SA 1760 Roosdaal, Belgium www.heidenhain.be	IN	HEIDENHAIN Optics & Electronics India Private Limited Chetpet, Chennai 600 031, India www.heidenhain.in	TR	T&M Mühendislik San. ve Tic. LTD. ŞTİ. 34775 Y. Dudullu – Ümraniye-Istanbul, Turkey www.heidenhain.com.tr
BG	ESD Bulgaria Ltd. Sofia 1172, Bulgaria www.esd.bg	IT	HEIDENHAIN ITALIANA S.r.l. 20128 Milano, Italy www.heidenhain.it	TW	HEIDENHAIN Co., Ltd. Taichung 40768, Taiwan R.O.C. www.heidenhain.com.tw
BR	DIADUR Indústria e Comércio Ltda. 04763-070 – São Paulo – SP, Brazil www.heidenhain.com.br	JP	HEIDENHAIN K.K. Tokyo 102-0083, Japan www.heidenhain.co.jp	UA	Gertner Service GmbH Büro Kiev 01133 Kiev, Ukraine www.heidenhain.ua
BY	GERTNER Service GmbH 220026 Minsk, Belarus www.heidenhain.by	KR	HEIDENHAIN Korea LTD. Gasan-Dong, Seoul, Korea 153-782 www.heidenhain.co.kr	US	HEIDENHAIN CORPORATION Schaumburg, IL 60173-5337, USA www.heidenhain.com
CA	HEIDENHAIN CORPORATION Mississauga, Ontario L5T2N2, Canada www.heidenhain.com	MX	HEIDENHAIN CORPORATION MEXICO 20290 Aguascalientes, AGS., Mexico E-mail: info@heidenhain.com	VE	Maquinaria Diekmann S.A. Caracas, 1040-A, Venezuela E-mail: purchase@diekmann.com.ve
CH	HEIDENHAIN (SCHWEIZ) AG 8603 Schwerzenbach, Switzerland www.heidenhain.ch	MY	ISOSERVE SDN. BHD. 43200 Balakong, Selangor E-mail: sales@isoserve.com.my	VN	AMS Co. Ltd HCM City, Vietnam E-mail: davidgoh@amsvn.com
CN	DR. JOHANNES HEIDENHAIN (CHINA) Co., Ltd. Beijing 101312, China www.heidenhain.com.cn	NL	HEIDENHAIN NEDERLAND B.V. 6716 BM Ede, Netherlands www.heidenhain.nl	ZA	MAFEMA SALES SERVICES C.C. Midrand 1685, South Africa www.heidenhain.co.za
CZ	HEIDENHAIN s.r.o. 102 00 Praha 10, Czech Republic www.heidenhain.cz	NO	HEIDENHAIN Scandinavia AB 7300 Orkanger, Norway www.heidenhain.no		
DK	TPTEKNIK A/S 2670 Greve, Denmark www.tp-gruppen.dk	PH	MACHINEBANKS' CORPORATION Quezon City, Philippines 1113 E-mail: info@machinebanks.com		

