

1.1 Program BLK form 1

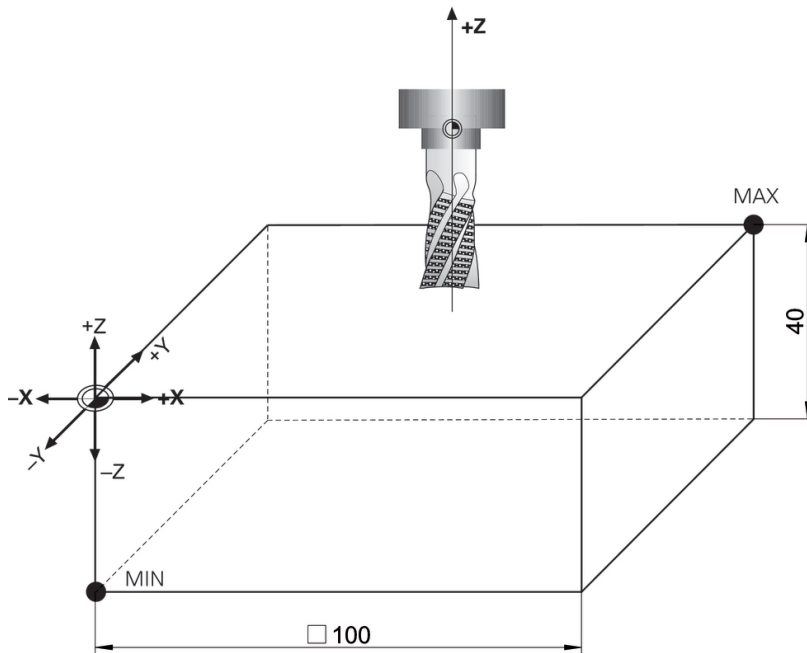

Program solution

0	BEGIN PGM BLK1 MM
1	BLK FORM 0.1 Z X+0 Y+0 Z-40
2	BLK FORM 0.2 X+100 Y+100 Z+0
3	END PGM BLK1 MM