



# HEIDENHAIN



Product Information

## **ERP 1080 Dplus**

High-Accuracy Angle Encoder  
without Integral Bearing

# ERP 1080 Dplus

- Very high system accuracy
- Resilient angle measurement
- Low mass and low mass moment of inertia
- Consisting of a scanning ring and a circular scale

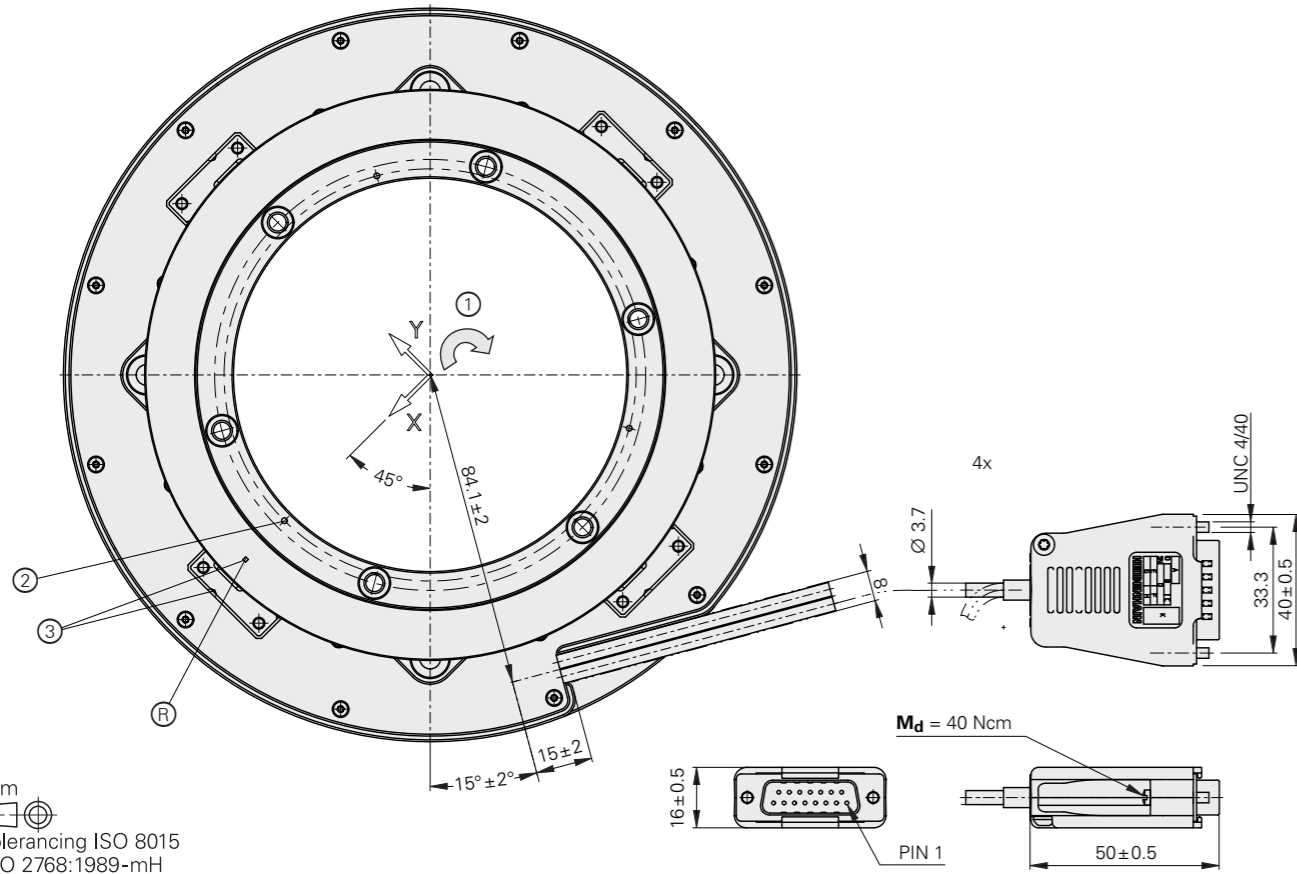
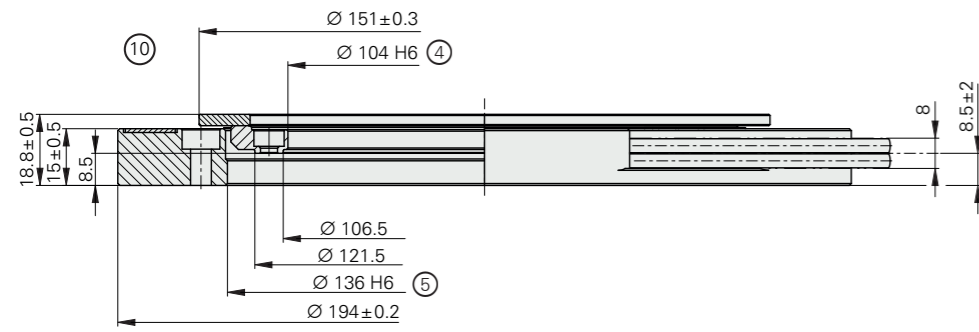

mm  
Tolerancing ISO 8015  
ISO 2768:1989-mH  
≤ 6 mm: ±0.2 mm

- ▢ = Bearing of mating shaft
- Ⓜ = Reference mark
- K1 = Required mating dimensions
- K2 = Required mating dimensions with centering collars
- 1 = Direction of shaft rotation for ascending position values
- 2 = Marks for circular scale centering (3 x 120°)
- 3 = Mark for 0° position
- 4 = Centering collar for scale hub
- 5 = Centering collar for scanning unit
- 6 = Screw: ISO 4762 – M5x16 – 8.8  
tightening torque: 500 Ncm ±30 Ncm;  
material bonding threadlocker required

- 7 = Screw: ISO 4762 – M4x12 – 8.8  
tightening torque: 220 Ncm ±13 Ncm;  
material bonding threadlocker required
  - 8 = Customer's mounted parts
  - 9 = Mounting surface must be clean and free of grease
  - 10 = Hub shown rotated by 45°
  - 11 = Depth of thread
- Steel  
Tensile strength:  $R_m > 600 \text{ N/mm}^2$   
Yield point:  $R_e > 400 \text{ N/mm}^2$   
Shear strength:  $\tau > 390 \text{ N/mm}^2$   
Elasticity module:  $20 \text{ °C: } E > 200000 \text{ N/mm}^2 \dots 215000 \text{ N/mm}^2$   
Coefficient of thermal expansion:  $20 \text{ °C: } (10 < \alpha < 13) \times 10^{-6} \text{ 1/K}$

K1

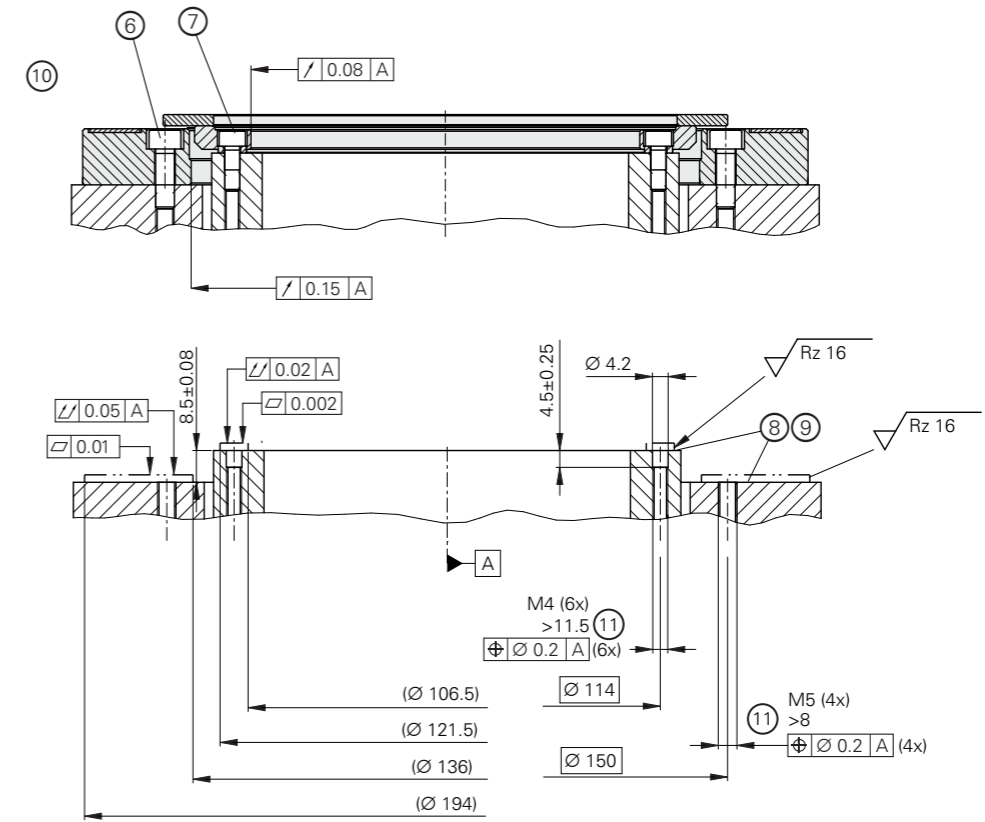

K2

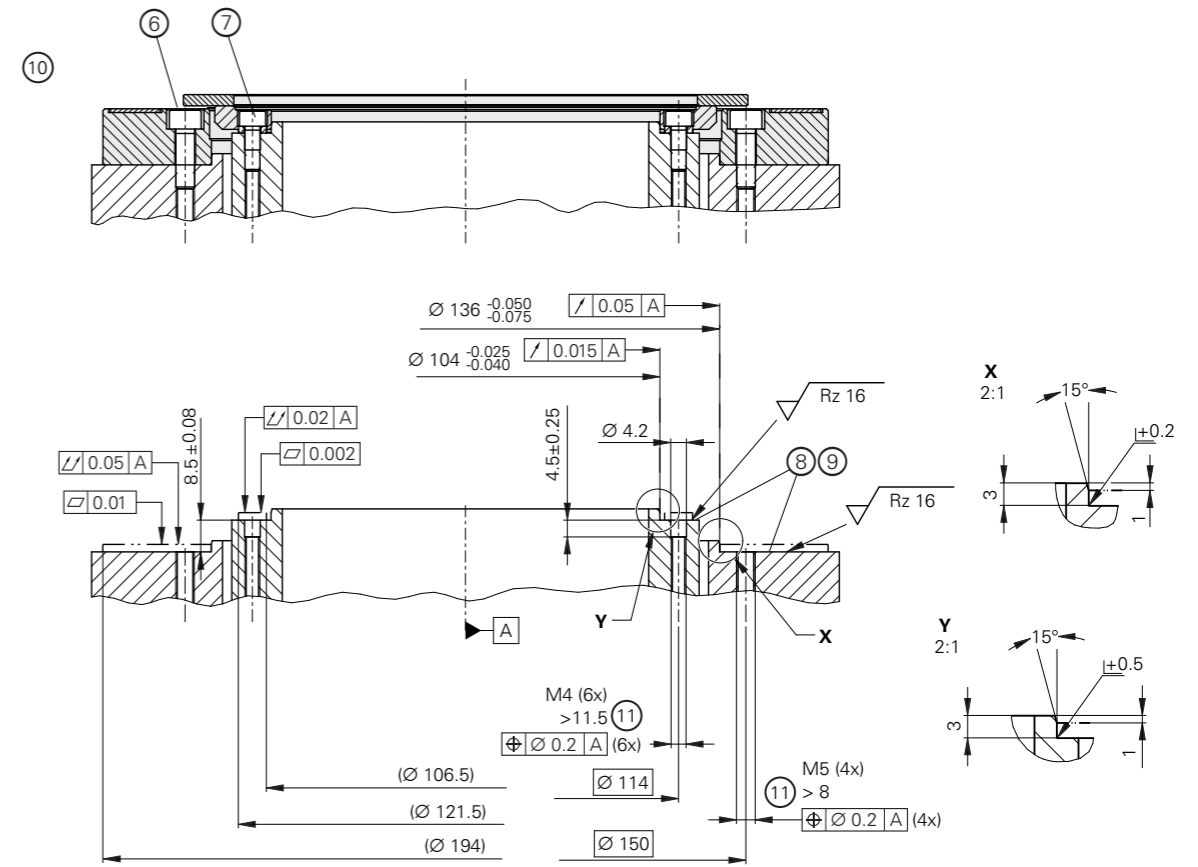

# Specifications

Encoder	ERP 1080 Dplus
<b>Interface</b> <sup>1)</sup>	4 x $\sim$ 1 V <sub>PP</sub>
Reference mark signal	Square-wave pulse
Cutoff frequency -3 dB	≥ 500 kHz
<b>Electrical connection</b> <sup>1)</sup>	Four 1.5 m cables with 15-pin D-sub connector (male)
Cable length <sup>1)</sup>	With HEIDENHAIN cable: ≤ 20 m; during signal adjustment with the PWM 21: ≤ 3 m
Voltage supply <sup>1)</sup>	DC 5 V ±0.5 V
Current consumption <sup>1)</sup>	≤ 150 mA (without load)
<b>Vibration</b> 55 Hz to 2000 Hz <b>Shock:</b> 6 ms	≤ 200 m/s <sup>2</sup> (EN 60068-2-6) ≤ 200 m/s <sup>2</sup> (EN 60068-2-27)
<b>Operating temperature</b>	0 °C to 50 °C
<b>Storage temperature</b>	-20 °C to 60 °C
<b>Mass</b>	Scanning ring ≈ 1.1 kg (without cable) Connector ≈ 75 g Cable ≈ 22 g/m Scale hub ≈ 289 g

<sup>1)</sup> Separate electrical connection for each scanning head

	ERP 1080 Dplus
<b>Measuring standard</b>	OPTODUR circular scale on glass
<b>Signal periods*</b>	63000
<b>System accuracy</b>	±0.4"
<b>Position error per signal period</b> <sup>1)</sup>	±0.02"
<b>RMS position noise</b> (500 kHz)	0.001"
<b>Reference marks</b>	One
<b>Outside diameter of scanning ring</b>	194 mm
<b>Inside diameter of hub</b>	104 mm
<b>Outside diameter of circular scale</b>	151 mm
Mech. permissible speed	≤ 950 rpm
Elec. permissible speed	≤ 475 rpm
Moment of inertia of the scale hub	$1.1 \cdot 10^{-3} \text{ kgm}^2$
<b>Protection</b> EN 60529	Complete, mounted encoder: IP00

<sup>1)</sup> The position error within one signal period and the accuracy of the graduation together yield the encoder-specific error; for additional mounting and bearing errors of the measured shaft, see *Measuring accuracy* in the *Modular Angle Encoders with Circular Scale* brochure.

## Transferable accuracy

In order to achieve accuracies in the high-end range, customers must often perform a very complex and time-consuming calibration of the entire machine. Under the motto “transferable accuracy,” HEIDENHAIN contributes to facilitating the mounting process for the customer and to transferring the high accuracy of our encoders to the customer’s application without any losses. For the ERP 1080 *Dplus* encoders, this is achieved based on the following features:

- Sturdy, mechanical interface for mounting on the customer side
- Four scanning heads for position calculation for resilient angle measurement

### Electrical connection

The ERP 1080 *Dplus* angle encoder provides four separate connections (D-sub, 15-pin) with 1 V<sub>PP</sub> interface. The EIB 74x signal converters that are available from HEIDENHAIN can be used to operate the product. The product can also be connected to downstream electronics from third-party suppliers if they provide four 1 V<sub>PP</sub> inputs.

### Position calculation with an EIB 74x or downstream electronics from third-party suppliers

For the system to be able to reach the specified accuracy, the positions of all scanning heads need to be averaged.

$$X_{\text{avg}} = \frac{(X1_{\text{abs}} + X2_{\text{abs}} + X3_{\text{abs}} + X4_{\text{abs}})}{4}$$



X<sub>1abs</sub> ... X<sub>4abs</sub>: Positions of the scanning heads

X<sub>avg</sub>: Arithmetic mean value of inputs X<sub>1abs</sub> to X<sub>4abs</sub>

## Electrical connection

### Pin layout

#### Pin layout

15-pin D-sub connector (male)															
	Power supply				Incremental signals						Other signals				
	4	12	2	10	1	9	3	11	14	7	13	15	5	6	8
	U <sub>P</sub>	Sensor U <sub>P</sub>	0V	Sensor 0V	A+	A-	B+	B-	R+	R-	Va-cant <sup>1)</sup>	Va-cant <sup>1)</sup>	Vacant	Vacant	Vacant
	Brown/ Green	/	White/ Green	/	Brown	Green	Gray	Pink	Red	Black	Violet	Yellow	/	/	/

**Shield** lies on housing; **U<sub>P</sub>** = Power supply voltage





**Sensor:** The sense line is connected in the connector with the corresponding power line.

Vacant wires and pins must not be used.

<sup>1)</sup> Required for signal adjustment with the PWM 21

# Cables

## Adapter cables and connecting cables for 1 V<sub>PP</sub>

<b>PUR</b> 6 x (2 x 0.19 mm <sup>2</sup> ); A <sub>P</sub> = 2 x 0.19 mm <sup>2</sup>			
<b>PUR</b> 4 x (2 x 0.14 mm <sup>2</sup> ) + (4 x 0.5 mm <sup>2</sup> ); A <sub>P</sub> = 2 x 0.5 mm <sup>2</sup>		Ø 8 mm	Ø 6 mm <sup>1)</sup>
<b>Adapter cable</b> with 15-pin D-sub connector (female) and 12-pin M23 connector (male)		331693-xx	355215-xx
<b>Adapter cable</b> with 15-pin D-sub connector (female) and 15-pin D-sub connector (male)		335074-xx	355186-xx
<b>Connecting cable</b> with 15-pin D-sub connector (female) and stripped cable end		332433-xx	355209-xx
<b>Connecting cable</b> with 15-pin D-sub connector (female) and 15-pin D-sub connector (female) with pin layout for the IK 220		335077-xx	349687-xx
<b>Signal cable</b> with stripped cable ends (for 15 pins)		816317-xx	816323-xx

<sup>1)</sup> Cable length for Ø 6 mm: max. 9 m  
A<sub>P</sub>: Cross section of power supply lines

## HEIDENHAIN

**DR. JOHANNES HEIDENHAIN GmbH**  
Dr.-Johannes-Heidenhain-Straße 5  
**83301 Traunreut, Germany**  
☎ +49 8669 31-0  
FAX +49 8669 32-5061  
info@heidenhain.de

[www.heidenhain.com](http://www.heidenhain.com)

This Product Information document supersedes all previous editions, which thereby become invalid. The basis for ordering from HEIDENHAIN is always the Product Information document edition valid when the order is placed.



### Further information:

Comply with the requirements described in the following documents to ensure correct and intended operation.

- Brochure: *Modular Angle Encoders with Circular Scale* 1401414-xx
- Brochure: *Interfaces of HEIDENHAIN Encoders* 1078628-xx